

Modelling and Simulation of a Biometric Identity-Based Cryptography

Dania Aljeaid

School of Science and Technology
Nottingham Trent University
Nottingham, United Kingdom

Xiaoqi Ma

School of Science and Technology
Nottingham Trent University
Nottingham, United Kingdom

Caroline Langensiepen

School of Science and Technology
Nottingham Trent University
Nottingham, United Kingdom

Abstract—Government information is a vital asset that must be kept in a trusted environment and efficiently managed by authorised parties. Even though e-Government provides a number of advantages, it also introduces a range of new security risks. Sharing confidential and top-secret information in a secure manner among government sectors tends to be the main element that government agencies look for. Thus, developing an effective methodology is essential and it is a key factor for e-Government success. The proposed e-Government scheme in this paper is a combination of identity-based encryption and biometric technology. This new scheme can effectively improve the security in authentication systems, which provides a reliable identity with a high degree of assurance. This paper also demonstrates the feasibility of using finite-state machines as a formal method to analyse the proposed protocols. Finally we showed how Petri Nets could be used to simulate the communication patterns between the server and client as well as to validate the protocol functionality.

Keywords—e-Government; identity-based cryptosystem; biometrics; mutual authentication; finite-state machine; Petri net.

I. INTRODUCTION

e-Government mainly acts as a communication bridge, whether from government to citizen, government to government, or government to business, in efficient and reliable ways through effective use of information technology. The main challenge in e-government is to develop a framework which promotes exchanging data securely among government agencies. While e-government provides a number of advantages, it also introduces a range of new security risks. Sharing confidential and top-secret information in a secure manner among government sectors tend to be the main element that government agencies look for.

When e-Government systems were being designed, **Public Key Infrastructure (PKI)** seemed to be the best solution for the scheme. PKI is presently deployed in most e-Government implementations, as it is perceived as a mature technology, which is widely supported and can be easily integrated with different systems. Examples of e-government initiatives that apply PKI on a large scale are the US eGov initiative (www.usa.gov) supported by Federal PKI [1] and the Saudi Arabian e-Government Program (yesser.gov.sa) [2].

One of the main issues concerning the security perspective in e-Government is to grant access to authorised users as well as the need to verify that the user is really who they claim to

be. The most common solution to this problem is to deploy a PKI [3] and digital signatures in large-scale e-Government systems. Even though PKI supports strong authentication and digital signature, it has a few disadvantages. For example, users must be pre-enrolled, certificate directories can leak some critical information, key recovery is difficult and costly and boundary services (anti-spam, anti-virus, archiving) integration is very difficult [4].

Thus, to take full advantage of the capabilities of e-Government, end users need robust security solutions to achieve assurance when dealing with e-Government systems. A variant of public key cryptography that derives public keys directly from unique identity information (such as an e-mail address) known by the user is called **Identity-Based Cryptography (IBC)**. This approach has recently received considerable attention from researchers [5, 6, 7, 8, 9], as the development of ID-Based Cryptography offers great flexibility and obviates the requirement for user certificates, since the identity of the user can be transformed into encryption keys and used for authentication.

To develop a new secure cryptosystem for e-Government, several schemes were investigated to determine which protocol would be suitable for the research. We propose a biometric-ID-based scheme using **Elliptic Curve Cryptosystem (ECC)**, which is an improved combination scheme derived from two schemes [10, 11]. The proposed scheme is secure under the **Computational Diffie-Hellman Assumption (CDHA)** and tackles the security drawbacks of He *et al.*'s scheme and Li and Hwang's scheme. To overcome these, we applied a symmetric key cryptosystem to prevent attackers from altering or gaining any important information in the login and authentication messages.

The structure of this paper is organised as follows. In Section 2, we review related works on ID-Based Cryptography and Biometric authentication and briefly describe both He *et al.*'s and Li and Hwang's schemes. In Section 3, we design the new Biometric-ID-based Authentication Scheme. In Section 4, we model the new protocol with finite-state machines. In Section 5, we model the new protocol with Petri Nets to simulate the communication. We then provide a brief discussion on security analysis and comparisons with related schemes in Section 6. Finally, the conclusion is given in Section 7.

II. REVIEW OF RELATED WORK

Without a secure and trusted infrastructure, organisations such as governments would leave data electronically unsecured and vulnerable to attacks. Therefore, governments are constantly looking for ways to deliver secure and reliable services. ID-Based Cryptography introduces a lightweight key management and offers encryption for data confidentiality and robust authentication, which are prerequisites for securing high-value transactions.

The idea of ID-based cryptography was originally proposed by Shamir in 1984 [12], but practical ID-based encryption schemes were not developed until recently. In 2001, Boneh & Franklin [5] developed a fully functional ID-based encryption scheme which can be constructed efficiently by using Weil pairing on elliptic curves.

In ID-based cryptosystems, there is a trusted third party called a **Private Key Generator (PKG)** who is responsible for generating the secret keys for all users. As a result, a PKG holds the users' private keys. If a PKG is malicious, it can impersonate any user and therefore decrypt any cipher text or forge signature on any message. This can lead to a problem known as key escrow [13, 14].

There is no question that the **Identity-Based Encryption (IBE)** scheme brings many advantages such as eliminating the need to distribute public keys. The enforcement of the private key generation by the Private Key Generator raises concerns of key escrow and/or privacy surrounding the management of private keys. To address this particular problem of key escrow, an implementation of biometric identification systems can be used as a private key. Biometric technology and verification systems offer a number of benefits to government sectors and users [15, 16].

He *et al.* [10] proposed an ID-based remote mutual authentication with key agreement scheme on ECC. This protocol attempts to cope with many of the well-known security and efficiency problems. However, the scheme has a potential flaw that may lead to man-in-the-middle attack and impersonation attack [17, 18]. It can be seen that, if an attacker E eavesdrops and listens to the communication between S_i and C_i , then E can intercept a valid login request $M_1 = \{ID_{C_i}, T_{C_i}, M, MAC_k(ID_{C_i}, T_{C_i}, M)\}$ or $h(ID_i || Xs)$ and masquerade as a legal user.

Biometric technologies are becoming fundamental elements in ensuring highly secure identification and personal verification solutions [15]. Biometric keys can be extracted from keystroke patterns, the human voice [19], fingerprints [20, 21], handwritten signatures [22], and facial characteristics [23].

Li and Hwang [11] proposed an efficient biometrics-based remote user authentication scheme using smart cards. The security of their scheme is based on one-way hash functions, biometric verification, smart card and it uses a nonce. The scheme is very efficient in computation cost, which has been proved to be relatively low compared with other related schemes [24, 25, 26, 27]. The scheme is composed of four

phases: the registration phase, the login phase, the authentication phase and password change phase.

One of the key characteristics of the cryptographic hash function is that the outputs are very sensitive to small perturbations in their inputs. Hash functions cannot be applied directly when the input data are noisy such as biometrics [28]. Therefore, a secure one-way hash function cannot be used for biometric verification. In the login phase of Li-Hwang's scheme, the user computes $h(B_i)$ based on a personal biometric template B_i . Then the biometric authentication process relies on comparing the hash value $h(B_i)$ with f_i . However, the scheme does not seem to be able to handle natural variation in the biometrics. For example, when the user logs in, his fresh biometric sample has to match exactly the template recorded during the registration phase, which never happens in practice. Thus, the protocol is fundamentally flawed and does not fulfil the basic objectives of a biometric authentication protocol. As a result, this may prevent a legal user from passing biometric verification at the login phase. So, Li-Hwang's scheme is vulnerable to denial-of-service attack. The scheme is also prone to man-in-the-middle attack and impersonation attack. The attacker can cheat the server by impersonating the user or can impersonate the server to cheat the user without knowing any secret information [29, 30, 31]

Combining ID based cryptography with biometric techniques can effectively improve the security in authentication systems, which provides a reliable identity with a high degree of assurance. The biometric technology is regarded as a powerful solution due to its unique link to an individual identity, which almost impossible to fake. Thus, a biometric identity is an inherent trait, which will always remain with the person all the time. In another words, using biometric techniques in IBE will mean that the person will always have their private key available.

III. PROPOSED SCHEME

This research will focus on secure e-Government systems and improve their authentication and communication. To guarantee the security of these distributed systems, biometrics verification and ID-based cryptography are used. The proposed protocol is based on the following assumptions:

- We assume that shared secrets in registration phase will never be disclosed.
- We assume that cryptographic algorithms are secure. For example, it is impossible to decrypt a ciphertext without prior knowledge of the secret key.
- We assume that both client and server are able to generate a random number securely.

The security of the proposed scheme is based on the intractability of the following two mathematical problems on elliptic curves [5, 10]:

- (i) **Computational Diffie–Hellman Assumption (CDHA):** Given $P, xP, yP \in G$, it is hard to compute $xyP \in G$.
- (ii) **Collision Attack Assumption 1 (k-CAA1):** For an integer k , and $x \in Z_n^*, P \in G$, given

$(P, xP, h_0, (h_1, (h_1+x)^{-1}P), \dots, (h_k, (h_k+x)^{-1}P))$, where $h_i \in Z_n^*$, and distinct for $0 \leq i \leq k$, it is hard to compute $(h_0+x)^{-1}P$.

The proposed scheme consists of four phases: system initialising phase, registration phase, login phase, and authentication phase. The notations used throughout this paper are summarised in Table 1.

TABLE.I. NOTATIONS USED IN THIS PAPER

Symbol	Definition
C_i	User/Client /Computer
S_i	Server
R_i	Registration Centre
ID_{S_i}	Identity of Server
ID_{C_i}	Identity of user C
PW_{C_i}	User's password
Bio_{C_i}	Biometric template of C
Pub_K	Public Key
Pr_K	Private Key
\parallel	Message concatenation operation
p, n	Two large prime numbers
F_p	A finite field
E	An elliptic curve over a finite field F
G	The group of elliptic curve points on E
P	A point on elliptic curve E with order n
xP	Denotes point multiplication on elliptic curve
y	A piece of secret information maintained by the server
$(x, \text{Pub_K}_s)$	The server S 's Private/Public key pair, where $\text{Pub_K}_s = xP$
r_{C_i}, r_{S_i}	A random number chosen by the C_i and S_i respectively
$H(\cdot)$	A secure one-way hash function
$\text{MAC}_k(m)$	The secure message authentication code of m under the key k
	XOR operation

A. System initializing phase

In this phase, we follow the steps in He *et al.*'s scheme where the server S_i generates parameters of the system.

Step 1: S_i chooses an elliptic curve equation $E_P(a, b)$.

Step 2: S_i selects a base point P with the order n over $E_P(a, b)$

Step 3: S_i selects its master key x and secret information y and computes public key $\text{Pub_K}_s = xP$

Step 4: The server chooses four secure one-way hash functions $H_1(\cdot), H_2(\cdot), H_3(\cdot), H_4(\cdot)$, where $H(\cdot)$ is a known hash function that takes a string and assigns it to a point on the elliptic curve, i.e. $H(A) = QA$ on E , where C is usually based on the identity

- $H_1(\cdot)$: a secure one-way hash function, where $H_1: \{0, 1\}^* \rightarrow Z_n^*$
- $H_2(\cdot)$: a secure one-way hash function, where $H_2: \{0, 1\}^* \rightarrow Z_p^*$
- $H_3(\cdot)$: a secure one-way hash function, where $H_3: \{0, 1\}^* \rightarrow Z_p^*$
- $H_4(\cdot)$: a secure one-way hash function, where $H_4: \{0, 1\}^* \rightarrow Z_p^*$

The server also chooses a message authentication code $\text{MAC}_k(m)$. Then, it keeps x private and publishes $\{F_p, E, n, P, \text{Pub_K}_s, H_1, H_2, H_3, H_4, \text{MAC}_k(m)\}$.

B. Registration Phase

A user C_i with identifier ID_{C_i} should be registered first before using the services provided by R_i . Users may use their employee number as an identity when contacting R_i for authorisation. In this phase, C_i needs to perform the following steps.

Step 1: User C_i inputs their ID_{C_i} , personal biometrics Bio_{C_i} , on a specific biometric device, and provides the password PW_{C_i} to R_i via a secure channel (or to the registration centre in person).

Step 2: R_i reads current timestamp T_{S_i} , and computes the following:

$$\begin{aligned} f_i &= H_4(Bio_{C_i}) \\ z_i &= H_4(PW_{C_i} \parallel f_i) \\ e_i &= H_4(ID_{C_i} \parallel y) \quad z_i \end{aligned}$$

Step 3: R_i computes C_i 's private key using the system private key x and C_i 's public key.

$$\text{Pr_K}_{C_i} = (x + H_4(ID_{C_i}))^{-1} P \in G$$

$$\text{Pub_K}_{C_i} = H_4((ID_{C_i} + x)P) = H_4((ID_{C_i})P + \text{Pub_K}_s)$$

Step 4: R_i stores $\{ID_{C_i}, H_4(\cdot), \text{Enc}\{ \}_a / \text{Dec}\{ \}_a, f_i, e_i, \tau, \text{Pr_K}_{C_i}\}$ on a secure database and sends it to the user via a secure channel, where $\text{Enc}\{ \}_a / \text{Dec}\{ \}_a$ is a symmetric encryption with secret key a and τ is a predetermined threshold [28] for biometric verification.

C. Login Phase

The user C_i sends a login request to the server S_i and performs the following steps:

Step 1: C_i enters the ID_{C_i} and PW_{C_i} , and then S_i verifies the authenticity of client's identity and password.

Step 2: C_i submits the Bio_{C_i} on specific biometric device, and then verifies the following:

$$\begin{cases} \text{Accept if } d(Bio_{C_i}, Bio_{C_i}^*) < \tau \\ \text{Reject if } d(Bio_{C_i}, Bio_{C_i}^*) \geq \tau \end{cases}$$

Step 3: if the above does not hold, it means the biometric information does not match the template

stored in the system. Thus C_i does not pass the biometric verification process and the authentication scheme is terminated. Otherwise, C_i passes the biometric verification and computes the following:

$$\begin{aligned} f_i &= H_4(\text{Bio}_{C_i}) \\ i &= H_4(PW_{C_i} \| f_i) \\ M_1 &= e_i \oplus z'_i = H_4(ID_{C_i} \| y) \\ W_1 &= r_{C_i} \cdot P \\ M_2 &= r_{C_i} \cdot \text{Pr_K}_{C_i} \\ M_3 &= M_1 \oplus r_{C_i} \end{aligned}$$

Where $r_{C_i} \in Z_n^*$ is a random number generated by the user. For this step, the random value r_{C_i} is introduced to mask the hash of the secret value $H_4(ID_{C_i} \| y)$.

Step 4: C_i computes $k = H_2(ID_{C_i}, T_{C_i}, W_1, M_2)$, where T_{C_i} is a timestamp denoting the current time.

Step 5: Finally, C_i encrypts the message $\{ID_{C_i}, T_{C_i}, W_1, M_3, \text{MAC}_k(ID_{C_i}, T_{C_i}, W_1, M_3)\}_a$ and sends it to the server S_i .

D. Authentication Phase

After receiving the request login message, S_i and C_i will perform the following steps for mutual authentication.

Step 1: S_i decrypts the message $\{ID_{C_i}, T_{C_i}, W_1, M_3, \text{MAC}_k(ID_{C_i}, T_{C_i}, W_1, M_3)\}_a$, then checks the validity of ID_{C_i} and the freshness of T_{C_i} . The freshness of T_{C_i} is checked by performing $T - T_{C_i} \leq \Delta T$, where T is the time when S_i receives the above message and ΔT is a valid time interval. The case where ID_{C_i} is not valid or T_{C_i} is not fresh, then S_i aborts the current session.

Step 2: If Step 1 holds, S_i computes the following:

$$\begin{aligned} M_2 &= (x + H_1(ID_{C_i})^{-1} W_1 \\ &= \text{Pr_K}_{C_i} \cdot r_{C_i} \end{aligned}$$

$$k = H_2(ID_{C_i}, T_{C_i}, W_1, M_2)$$

S_i checks the integrity of $\text{MAC}_k(ID_{C_i}, T_{C_i}, W_1, M_3)$ with the key k . S_i will quit the current session if the check produces a negative result.

Step 3: If Step 2 holds, S_i chooses a random number $r_{S_i} \in Z_n^*$ and computes the following:

$$M_4 = H_4(ID_{C_i} \| y)$$

$$W_2 = r_{S_i} \cdot P$$

$$K_{S_i} = r_{S_i} \cdot W_1$$

The session key $sk = H_3(ID_{C_i}, T_{C_i}, T_{S_i}, W_1, W_2, K_{S_i})$, where T_{S_i} is a timestamp denoting the current time

$$M_5 = M_3 \quad M_4 = r_{C_i}$$

$$M_6 = M_4 \quad r_{S_i}$$

$$M_7 = H_4(M_3 \| M_5)$$

Where M_5 is the random value r_{C_i} of the user C_i and only S_i can unmask the value because it can compute $H_4(ID_{C_i} \| y)$

Step 4: Then, S_i encrypts the message $\{ID_{C_i}, T_{S_i}, W_2, M_6, M_7, \text{MAC}_k(ID_{C_i}, T_{S_i}, W_2, M_6, M_7)\}_a$ and sends it to C_i

Step 5: Upon receiving the S_i 's message, C_i first decrypts $\{ID_{C_i}, T_{S_i}, W_2, M_6, M_7, \text{MAC}_k(ID_{C_i}, T_{S_i}, W_2, M_6, M_7)\}_a$, and checks the freshness of T_{S_i} is by performing $T - T_{S_i} \leq \Delta T$, where T is the time when C_i receives the above message and ΔT is the expected time interval for the transmission delay.

Step 6: C_i verifies whether $M_7 \stackrel{?}{=} H_4(M_3 \| r_{C_i})$ and checks the integrity of $\text{MAC}_k(ID_{C_i}, T_{S_i}, W_2, M_6, M_7)$ with the key k . C_i will quit the current session if the check produces a negative result.

Step 7: If it holds, C_i believes that S_i is authenticated and then computes the following:

$$K_{C_i} = r_{C_i} \cdot W_2$$

The session key $sk = H_3(ID_{C_i}, T_{C_i}, T_{S_i}, W_1, W_2, K_{C_i})$

$$M_8 = M_6 \quad M_1 = r_{S_i}$$

$$M_9 = H_4(M_6 \| M_8)$$

Where M_9 is the random value r_{S_i} of the server S_i and only the client C_i , which know $M_1 = H_4(ID_{C_i} \| y)$, can send back the correct hashed value of $M_9 = H_4(H_4(ID_{C_i} \| y) \quad r_{S_i} \| r_{S_i})$

Step 8: C_i sends the encrypted message $\{M_9, \text{MAC}_k(M_9)\}_a$ to S_i

Step 9: After receiving C_i 's message, S_i decrypts $\text{Enc}\{M_9\}_a$ and check the integrity of $\text{MAC}_k(M_9)$. Then, S_i verifies whether $M_9 \stackrel{?}{=} H_4(M_6 \| r_{S_i})$

Step 10: If the above mentioned holds, S_i accept C_i 's login request or otherwise rejects it

IV. BEHAVIOUR MODELLING AND STATE MACHINE

Verification is a crucial step in designing security protocols. A Finite-State Machine (FSM) is a powerful tool to simulate software architecture and communication protocols. FSM can only model the control part of a system and consists of a finite number of states, finite number of events, and finite number of transitions. An FSM may be regarded as a five-tuple [32]: $(Q, \Sigma, \Delta, \sigma, q_0)$, where:

- Q : finite set of symbols denoting states
- Σ : set of symbols denoting the possible inputs
- Δ : set of symbols denoting the possible outputs
- σ : transition function mapping to $Q \times \Sigma$ to $Q \times \Delta$
- $q_0 \in Q$: initial state.

The FSM is used to model the communication channel of proposed protocol between the Client C_i and the Server S_i .

Since the exchange of packets follows a pattern defined by a finite set of rules, it will be described by creating three finite-state machines FSM_{server} , $FSM_{register}$ and FSM_{client} .

A. Server FSM

The FSM at the server side represents the various on-going communications with the client at any point of time. It is modelled using 10 states and 22 transitions as detailed below. Fig. 1 shows the transitions diagram for the FSM_{server} .

1) The FSM_{server} will loop itself as the server is waiting for clients. The machine advances to the next state once it is triggered by a login/enrol transition accordingly.

2) When the FSM_{server} is in the state S1, it checks the validity of the received ID. If ID proved to be incorrect, S_i will request C_i to enter the valid ID for three times and FSM_{server} will loop until C_i enters the valid ID or if the attempts exceed three times. In the latter case, the C_i 's account will be blocked and FSM_{server} changes state to S4 from state S1. Generally, three attempts are made through our protocol steps to allow common errors.

3) When the FSM_{server} is in the state S2, it is triggered by valid ID and it is now waiting for a valid PW. Once S_i receives PW, it verifies its validity. If PW proved to be wrong, S_i will request C_i to enter the valid PW for three times and FSM_{server} will loop until C_i enters the valid PW or if the attempts exceed three times. In the latter case, the C_i 's account will be blocked and FSM_{server} changes state to S4 from state S2.

4) When the FSM_{server} is in the state S3, it is triggered by valid PW and it is now waiting for a valid Bio. Once S_i receives Bio, it verifies its validity by comparing the imprinted Bio with the template stored. If Bio does not match the stored template, S_i will request C_i to enter the valid Bio up to three times and the FSM_{server} will loop until C_i enters the valid PW or if the attempts exceed three times. In the latter case, the C_i 's account will be blocked and the FSM_{server} changes state to S4 from state S3.

5) In state S5, the FSM_{server} waits until receiving the login request $SYN = \{ID_{C_i}, T_{C_i}, W_1, M_3, MAC_k(ID_{C_i}, T_{C_i}, W_1, M_3)\}_a$

from the FSM_{client} to establish a connection by performing three-ways-handshake.

6) While in State S5, the FSM_{server} checks the validity of ID, freshness of T and the integrity of MAC_k . Then S_i generates a random number and timestamp in order to calculate the session key $sk = H_3(ID_{C_i}, T_{C_i}, T_{S_i}, W_1, W_2, K_{S_i})$. After that, S_i replies $SYN/ACK = \{ID_{C_i}, T_{S_i}, W_2, M_6, M_7, MAC_k(ID_{C_i}, T_{S_i}, W_2, M_6, M_7)\}_a$ to the FSM_{client} .

7) In state S6, FSM_{server} waits until receiving ACK from the FSM_{client} . Once the FSM_{client} sends $ACK = \{M_9\}_a$, FSM_{server} verifies $M_9 \stackrel{?}{=} H_4(M_6 || r_{S_i})$. At this instance, S_i authenticates C_i as a legitimate user.

8) At state S5 and state S6, FSM_{server} terminates the current session if any of the following situations occurs:

- The client ID is invalid
- The freshness of $T - T_{C_i} \geq \Delta T$
- Negative result when checking the integrity of $MAC_k(ID_{C_i}, T_{C_i}, W_1, M_3)$
- If $M_9 \neq H_4(M_6 || r_{S_i})$

At any stage of FSM_{server} , FSM_{server} aborts the current session and changes to state S9 if the timeout exceeds the defined TIME_WAIT while waiting for packets. This feature helps to prevent an infinite wait when the FSM_{client} fails to response.

B. Client FSM

The FSM at the client side represents the various on-going transmissions with the server at any point of time. It is modelled using 9 states and 21 transitions as detailed below. Fig. 1 shows the transitions diagram for the FSM_{client} .

1) First, the FSM_{client} is in the initial state C0 that is when the request for register/login is initiated by itself. While in state C0, the FSM_{server} checks whether C_i is enrolled or not. The next state will

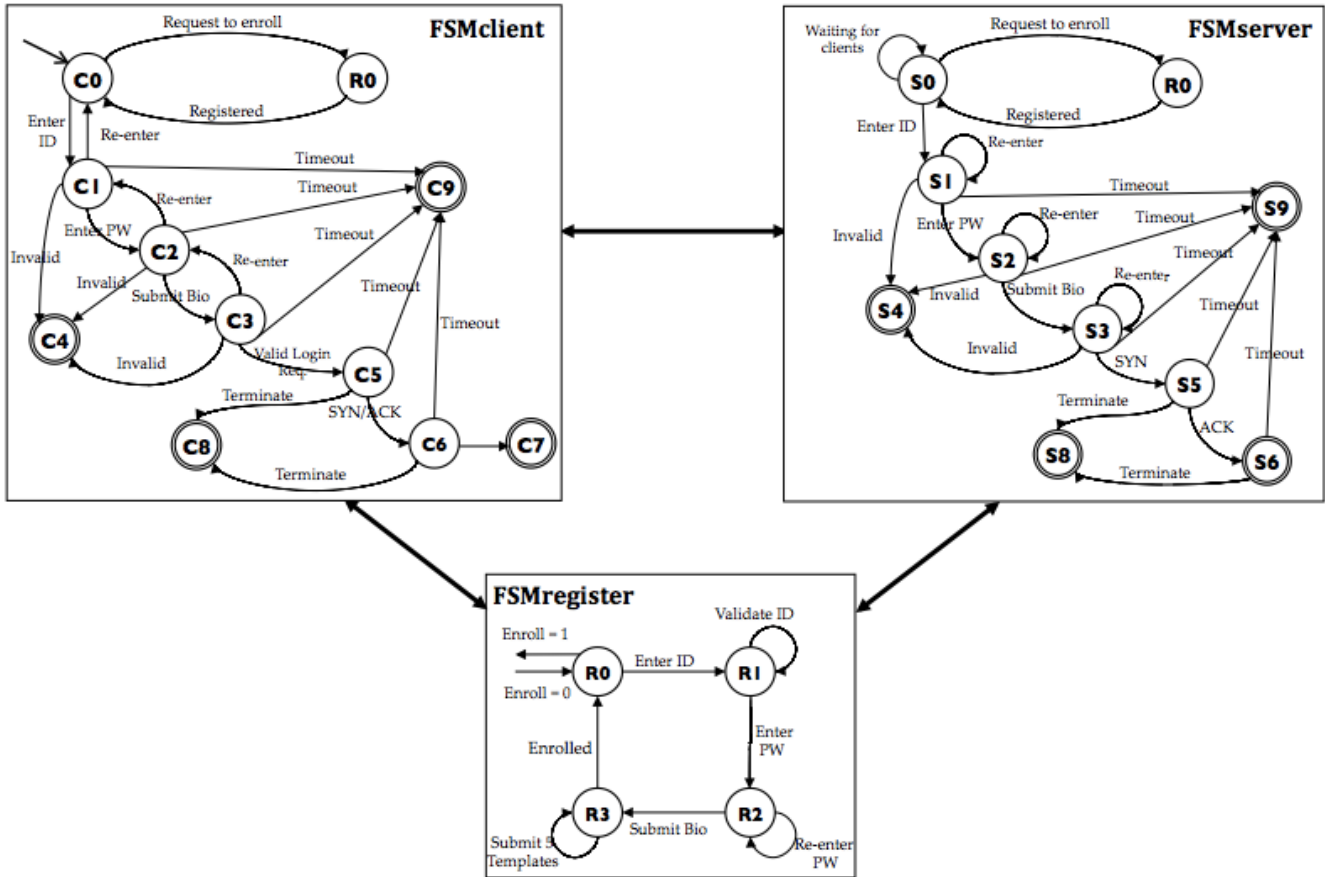

Fig.1. Proposed protocol FSM model

be decided according to the condition $ClientReg == True$.

2) In states $C1, C2, C3$, the FSM_{client} is waiting for validating ID, PW, and Bio. Once the client credentials are validated, the FSM_{client} triggers itself and changes to state $C5$.

3) In states $C1, C2, C3$, the client may require to re-enter ID, PW, Bio in case if they were incorrect. However, the client's account will be blocked if the number of attempts exceeds three trials, which change the above states to state $C4$.

- $ID_attempt < 3, ID_attempt = ID_attempt + 1$
- $PW_attempt < 3, PW_attempt = PW_attempt + 1$
- $Bio_Attempt < 3, Bio_attempt = Bio_attempt + 1$

4) While in state $C5$, the FSM_{client} is waiting for the FSM_{server} response after sending the login request to establish the connection.

5) In state $C6$, the FSM_{client} is validating the FSM_{server} response by checking the integrity of $MAC_k, \Delta T$ and $M_7 \stackrel{?}{=} H_4(M_4 || r_{C_i})$. If S_i is proved to be honest, C_i authenticates S_i at this stage.

6) While in state $C6$, the FSM_{client} computes the shared session key $sk = H_3(ID_{C_i}, T_{C_i}, T_{S_i}, W_1, W_2, K_{C_i})$ and finalises the handshake procedure by sending $ACK = \{M_9\}_a$ to S_i .

7) In state $C7$, the FSM_{client} is waiting to be authenticated by S_i .

8) In state $C8$, the client terminates the current session if one of the following occurs:

- Negative result when checking the integrity of MAC_k
- The freshness of $T' - T_{S_i} \geq \Delta T$
- $M_7 \stackrel{?}{=} H_4(M_4 || r_{C_i})$

At any stage of FSM_{client} , FSM_{client} aborts the current session and changes to state $C9$ if the timeout exceeds the defined TIME_WAIT while waiting for packets. This feature helps to prevent an infinite wait when the FSM_{server} fails to response.

C. Register FSM

The FSM at Registration side represents the various ongoing transmissions with the server and client at any point of time. It is modelled using 4 states and 7 transitions as detailed below. Fig. 1 shows the transitions diagram for the $FSM_{register}$.

1) First, the $FSM_{register}$ is triggered if the client is not enrolled $R0$, that is when the request for register is initiated by

FSM_{client} . While in state $C0$, the FSM_{server} checks whether C_i is enrolled.

2) When once C_i enters ID , $FSM_{register}$ changes to state $R1$ and validates the format of ID . $FSM_{register}$ triggers itself. Then $FSM_{register}$ asks C_i to enter PW and changes to state $R2$.

3) In state $R2$, on receiving PW for the first time, $FSM_{register}$ requires C_i to re-enter PW for confirmation. Then it triggers and changes to the state $R3$.

4) In state $R3$, C_i is required to submit multiple scans of the biometric data to increase accuracy. Once the acquisition process is complete, $FSM_{register}$ trigger itself and sends a message to $R0$, which indicates that the enrolment is successful.

V. PROTOCOL MODEL AND PETRI NETS

Due to the unique characteristics possessed by cryptographic protocols, analysis and evaluation tend to be more difficult than normal protocols. Petri Nets (PN) [33] offer a way to simulate the communication patterns between the server and client as well as to validate the protocol functionality.

Petri nets are a finite-state analysis approach that explicitly provides a graphical description for cryptographic protocols. The formal definition of a Petri net is shown in Table 2 [35]. Generally Petri nets focus on specific properties such as liveness, deadlock, livelock, boundedness and safeness [34,35,36]. Typically, a petri net must consist of the following components [35]:

- A set of *places* (drawn as circles in the graphical representation) represent conditions and possible states of the system.
- A set of *transitions* (drawn as rectangles or thick bars) represent a change of state which is caused by events or actions.
- A set of *arcs* (drawn as arrows) connecting a place to a transition and vice versa.
- *Tokens* (drawn as black dots) occupy places to represent the truth of the associated condition.

TABLE.II. FORMAL DEFINITION OF A PETRI NET

<p>A Petri net is 5-tuple, $PN=(P,T,F,W,M_0)$ where: $P=\{p_1, p_2, \dots, p_m\}$ is a finite set of places, $T=\{t_1, t_2, \dots, t_n\}$ is a finite set of transitions, $F \subseteq (P \times T) \cup (T \times P)$ is a set of arcs (flow relations), $W:F \rightarrow \{1, 2, 3, \dots\}$ is a weight function, $M_0:P \rightarrow \{0, 1, 2, 3, \dots\}$ is the initial marking, $P \cap T = \emptyset$ and $P \cup T \neq \emptyset$.</p> <p>A Petri net structure $N=(P, T, F, W)$ without any specific initial marking is denoted by N.</p> <p>A Petri net with the given initial marking is denoted by (N, M_0).</p>

Our technique involves simulation and verification by using Time-arc Petri nets. Initially, we build a PN model for client-server without intruder using TAPAAL simulation and verification software [37]. Moreover, it is worth to consider the following:

- Define the places and transitions and declare their functionalities
- Implement a token passing scheme once the initial marking is set.
- Assess the model behaviour by examine reachability, boundedness, liveness.

The Petri net model in Fig. 2 represents the proposed protocol. The definitions of the places and transitions used in this model are illustrated in Table 3 and Table 4, respectively.

In our PN model, *places* mostly represent storage for requests, messages, ciphers, or session keys. *Transitions* represent actions that transform a current state to a new one. For example, the following events produce a new state: encryption, decryption, verification, and computations. *Tokens* are modelled in PN as shown in Fig. 2 to represent the key agreement and message exchange between the client and server. During simulation, the token firing rule imitates the three-way handshake procedure.

TABLE.III. DEFINITIONS OF PLACES FOR THE PROPOSED MODEL

Place	Definition	Place	Definition
P_1	Client random number	P_{14}	Encrypted SYN/ACK
P_2	Client timestamp	P_{15}	Decrypted SYN/ACK
P_3	SYN request	P_{16}	Verification message
P_4	Login request	P_{17}	Rejected request
P_5	Encrypted login request	P_{18}	Accept request – Server is authenticated
P_6	Decrypted login req.	P_{19}	Session key
P_7	Verification message	P_{20}	ACK
P_8	Rejected request	P_{21}	Encrypted ACK
P_9	Accepted request	P_{22}	Decrypted ACK
P_{10}	Server random number	P_{23}	Verification message
P_{11}	Server timestamp	P_{24}	Rejected request
P_{12}	Session Key	P_{25}	Accept request – Client is authenticated
P_{13}	SYN/ACK		

TABLE.IV. DEFINITIONS OF TRANSITIONS FOR PROPOSED MODEL

Trans.	Definition	Trans.	Definition
T_1	Compute login request + SYN	T_{10}	Split the packet and verify
T_2	Encrypt	T_{11}	Drop the packet
T_3	Decrypt	T_{12}	Accept
T_4	Split the packet and verify	T_{13}	Compute ACK and session key
T_5	Drop the request	T_{14}	Encrypt ACK
T_6	Accept	T_{15}	Decrypt ACK
T_7	Compute SYN/ACK and session key	T_{16}	Split the packet and verify
T_8	Encrypt SYN/ACK	T_{17}	Drop the packet
T_9	Decrypt SYN/ACK	T_{18}	Accept

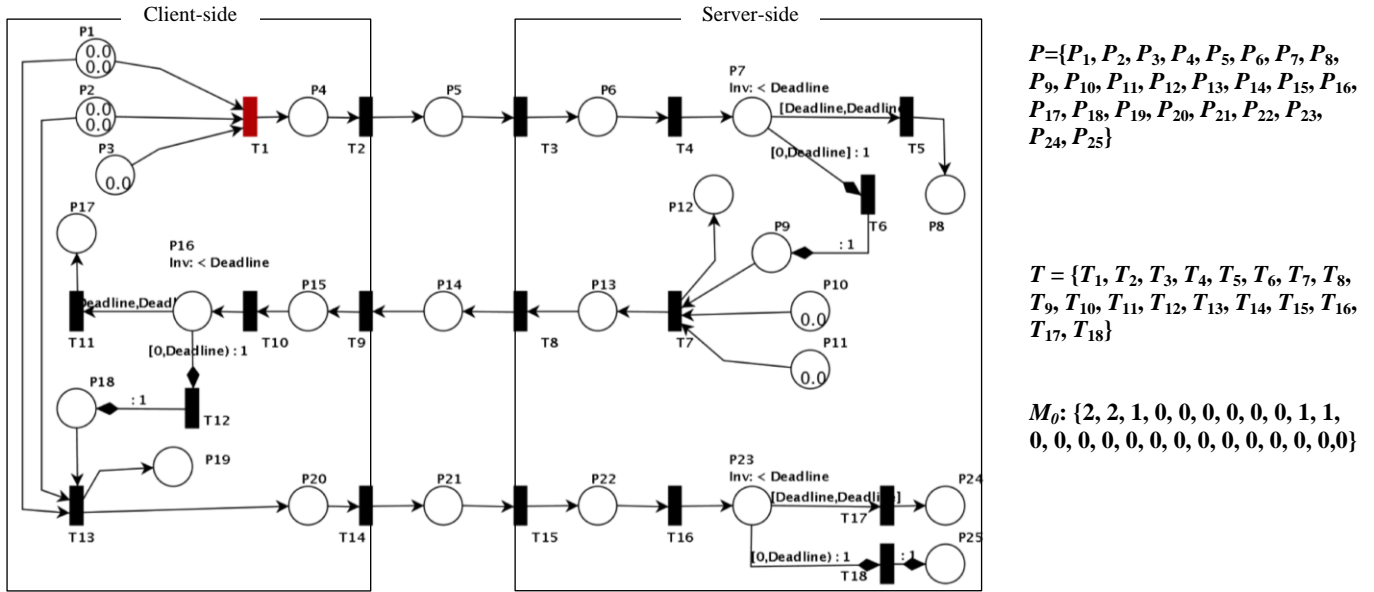

Fig.2. The Petri net graph representing the new protocol.

After modeling the proposed protocol, it is essential to examine the behavioral properties of the model. Detailed behavioral properties for Petri nets can be found in [35]. Generating Reachability graph (Fig. 3) allows identifying the presence and absence behaviors of the modeled protocol.

A. Reachability:

Reachability or coverability can be conducted by numerating all states. In other words, deriving all the possible marking the protocol can reach in the model. This method can clearly identify all the enabled transition starting from the initial state and generating new states after firing transitions. The PN shown in Fig. 2 is bounded. This is evident from the reachability graph (Fig. 3), all set of reachable marking M_i , where $i=\{0,1,2,\dots,19\}$ are said to be reachable, that is to say there exists a sequence of transition firings which transform one marking state to another.

B. Boundedness and safeness:

Boundedness helps to detect overflows in the modeled system. This property is an indication of stability behavior of model. It is evident that the proposed PN is structurally bounded, for each place in the net hold at most 2 tokens given an initial marking m_0 , that is to say that there are a finite number of states in the modeled protocol. Thus, the PN has no self-loop and satisfies the condition [35]:

A Petri net is k-bounded if all its places are k-bounded
A Petri net is structurally bounded if it is bounded in any initial marking

Hence, We can say that the PN is structurally 2-bounded, however, the PN is not safe because there are two nodes (P_1, P_2) contains more than one token. It does not fulfill the safeness condition, which is 1-boundedness.

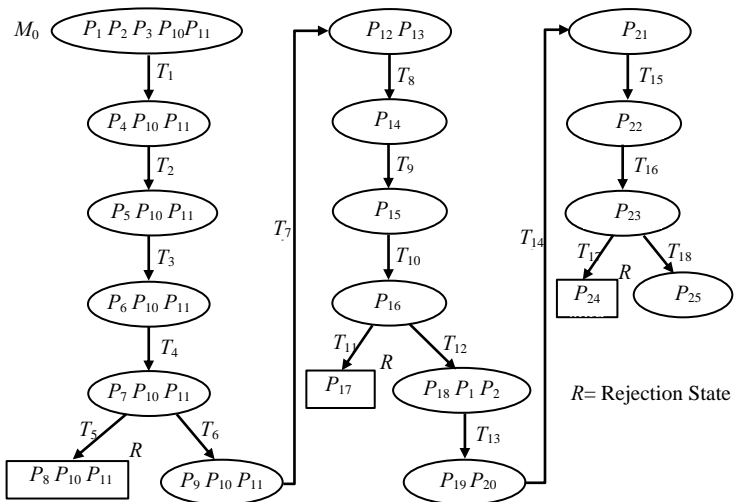

Fig.3. Reachability graph for proposed model

C. Liveness

The PN has a finite number of dead markings. The transitions (T_5, T_{11}, T_{17}) connected to places (P_8, P_{17}, P_{24}) respectively are not live if the protocol runs smoothly. Apart from that, the rest of places and their corresponding firing transitions are live. Occurrence of deadlocks (Rejection state) as shown in Fig. 3 is a result for aborting the current session between the client and serve; the token age exceeds the deadline.

Since PN contains deadlocks and not live, then the PN is considered not reversible.

VI. SECURITY ANALYSIS AND COMPARISONS

The analysis suggests that the proposed scheme is well-designed for data confidentiality by using symmetric

cryptography during the handshake procedure. Also, it ensures data integrity by applying a Message Authentication Code function (MAC). Typically, the MAC function takes as input a secret key and data block and produces a hash value [38]. The client and server transmit the MAC value during the login and authentication phases. However, both client and server will be aware if an attacker alters the message because the integrity check of MAC value fails. When the communication session between C_i and S_i is over, the session key sk is discarded and a new session key is used in every protocol run to prevent a replay attack.

Mutual authentication and session key agreement

Based on FSM model and PN model, we proved that the protocol accomplished mutual authentication and secret session key agreement between a remote client and the server by establishing three-way challenge-response handshake technique. First, the client C_i sends the login request message $\{ID_{C_i}, T_{C_i}, W_1, M_3, MAC_k(ID_{C_i}, T_{C_i}, W_1, M_3)\}$ to the server S_i . Then S_i verifies the received message by checking the MAC integrity. After validating, S_i sends a challenge message $\{ID_{C_i}, T_{S_i}, W_2, M_6, M_7, MAC_k(ID_{C_i}, T_{S_i}, W_2, M_6, M_7)\}$ to C_i . Next, C_i check the validity of the received message $M_7 \stackrel{?}{=} H_4(M_4 || r_{C_i})$ and accept or reject the server request according to the verification result. Finally, C_i sends a response message $M_9 = H_4(H_4(ID_{C_i} || y) \oplus r_{S_i} || r_{S_i})$ to S_i . Upon receiving the message, S_i verifies if $M_9 \stackrel{?}{=} H_4(M_6 || r_{S_i})$ holds. If so, S_i authenticates client C_i and allows him to get access. During the process, both S_i and C_i compute the session key $sk = H_3(ID_{C_i}, T_{C_i}, T_{S_i}, W_1, W_2, (r_{S_i}, r_{C_i}, P))$ successfully.

Denial-of-service-attack

Our scheme can withstand denial-of-service attack, because when the client C_i imprints personal biometrics $Bio^*_{C_i}$, the S_i will check the validity of $Bio^*_{C_i}$ with stored template by checking whether $d(Bio_{C_i}, Bio^*_{C_i}) < \tau$ holds. According to [31], the $Bio^*_{C_i}$ could pass the verification process even though there is some slight difference between $Bio_{C_i}, Bio^*_{C_i}$.

As for the computation cost, the proposed protocol is relatively low cost and efficient since only symmetric encryption; hash operations and XOR operations are required. Moreover, it is based on ECC which has significant advantages over other public-key cryptography. ECC provides the same security level of RSA cryptosystem but with a shorter key length and faster computation [39]

In Table 5, we summarised the performance and demonstrated comparisons between the proposed scheme and other related schemes. The evaluation parameters are defined in Table 6. Even though the number of operations is more than in other schemes, our scheme holds other security properties. The proposed protocol is based on a two-factor user authentication mechanism and it is obvious that it takes few more hash operations and XOR operations for the server and client. Due to the security weaknesses in related schemes, we

applied symmetric encryption and symmetric decryption to ensure the confidentiality and the integrity of transmitted packets. Therefore this feature makes the proposed scheme effective.

TABLE.V. PERFORMANCE COMPARISONS

	He et al.'s Scheme	Li-Hwang's Scheme	Proposed Scheme
Client	$2T_H + 2T_{MAC}$	$3T_H + 3T_X$	$6T_H + 3T_X + 3T_{MAC} + 2T_{SE} + T_{SD}$
Server	$4T_H + 2T_{MAC}$	$4T_H + 2T_X$	$6T_H + 2T_X + 3T_{MAC} + 1T_{SE} + 2T_{SD}$

TABLE.VI. EVALUATION PARAMETERS

Symbol	Definition
T_X	Time for executing an XOR operation
T_H	Time for executing a one-way hash function
T_{MAC}	Time for executing a message authentication code
T_{SE}	Time for executing a symmetric encryption operation
T_{SD}	Time for executing a symmetric decryption operation

VII. CONCLUSION AND FUTURE WORK

The paper demonstrates how a combination of ID-based encryption with biometrics can be effective and more suited to e-Government environments. Moreover, the new biometric-identity-based scheme can be integrated into e-Government systems as the main authentication method and for secure communication as well. The proposed scheme is aimed to initiate secure authentication and communication between the client and server by building a robust mechanism between communicating government parties. The presented protocol is described as a three-way handshake procedure to establish a reliable connection and ensure secure data sharing. Moreover, we have simulated and validated the behaviour of the proposed protocol by using finite-state machines and Petri nets.

In future, an in-depth security analysis and evaluation will be conducted to thoroughly assess for security vulnerabilities and weaknesses. Furthermore, it is essential to consider using Petri Nets to add an intruder model and implement a token-passing scheme. At this stage, we will examine different attacks, such as impersonation attack, man-in-the-middle attack, and replay attack against the proposed scheme and verify its security.

ACKNOWLEDGMENT

This research has been funded by Saudi Arabian Cultural Bureau in London and King Abdul Aziz University in Saudi Arabia.

REFERENCES

[1] Caloyannides, M., authentication framework and programs. IT professional, , pp. 16-21.

- [2] Sahraoui, S., Gharaibeh, G. And Al-Jboori, A., 2006. E-Government in Saudi Arabia: Can it overcome its challenges, e-Government Workshop 2006.
- [3] Evans, D. And Yen, D.C., 2005. E-government: An analysis for implementation: Framework for understanding cultural and social impact. *Government Information Quarterly*, 22(3), pp. 354-373.
- [4] Voltage Security, 2006. Identity-Based Encryption and PKI Making Security Work. http://www.voltage.com/pdf/IBE_and_PKI.pdf edn. Voltage Security, Inc.
- [5] Boneh, D. And Franklin, M., 2001. Identity-based encryption from the Weil pairing, *Advances in Cryptology—CRYPTO 2001* 2001, Springer, pp. 213-229.
- [6] Gentry, C. and Silverberg, A., 2002. Hierarchical ID-based cryptography. *Advances in Cryptology—ASIACRYPT 2002*, , pp. 149-155.
- [7] Al-Riyami, S. and Paterson, K., 2003. Certificateless public key cryptography. *Advances in Cryptology-ASIACRYPT 2003*, , pp. 452-473.
- [8] Boneh, D. and Boyen, X., 2004. Efficient selective-ID secure identity-based encryption without random oracles, *Advances in Cryptology-EUROCRYPT 2004* 2004, Springer, pp. 223-238.
- [9] Duffy, A. And Dowling, T., 2004. An object oriented approach to an identity based encryption cryptosystem, *Software Engineering and Applications 2004*, ACTA Press.
- [10] He, D., Chen, J. And Hu, J., 2012. An ID-based client authentication with key agreement protocol for mobile client-server environment on ECC with provable security. *Information Fusion*, 13(3), pp. 223-230.
- [11] Li, C.T. And Hwang, M.S., 2010. An efficient biometrics-based remote user authentication scheme using smart cards. *Journal of Network and Computer Applications*, 33(1), pp. 1-5.
- [12] Shamir, A., 1985. Identity-based cryptosystems and signature schemes, *Advances in cryptology* 1985, Springer, pp. 47-53.
- [13] Liao, J., Xiao, J., Qi, Y., Huang, P. and Rong, M., 2005. ID-based signature scheme without trusted PKG, *Information Security and Cryptology* 2005, Springer, pp. 53-62.
- [14] Yuen, T., Susilo, W. and Mu, Y., 2010. How to construct identity-based signatures without the key escrow problem. *Public Key Infrastructures, Services and Applications*, , pp. 286-301.
- [15] Vacca, J.R., 2007. *Biometric technologies and verification systems*. Oxford: Butterworth-Heinemann.
- [16] Vielhauer, C., 2005. *Biometric user authentication for IT security: from fundamentals to handwriting*. New York ; London: Springer.
- [17] Islam, S.H. and Biswas, G., 2012. An improved ID-based client authentication with key agreement scheme on ECC for mobile client-server environments. *Theoretical and Applied Informatics*, 24(4), pp. 293-312.
- [18] Wang, D. and Ma, C., 2013. Cryptanalysis of a remote user authentication scheme for mobile client-server environment based on ECC. *Information Fusion*, .
- [19] Monrose, F., Reiter, M.K., Li, Q. and Wetzels, S., 2001. Cryptographic key generation from voice, *Security and Privacy, 2001. S&P 2001. Proceedings. 2001 IEEE Symposium on* 2001, IEEE, pp. 202-213
- [20] Seto, Y., 2002. Development of personal authentication systems using fingerprint with smart cards and digital signature technologies, The Seventh International Conference on Control, Automation, Robotics and Vision.
- [21] Clancy T.C., Kiyavash, N. and D.J. Lin, D.J., 2003. *Secure smart card based fingerprint authentication*, Proceedings of the 2003 ACM SIGMM Workshop on Biometrics Methods and Application, WBMA.
- [22] Hao, F., Chan, C.W., 2002. Private key generation from on-line handwritten signatures, *Information Management & Computer Security*, Issue 10, No. 2, pp. 159-164.
- [23] Goh, A. and Ngo, D., 2003. Computation of cryptographic keys from face biometrics. *Communications and Multimedia Security. Advanced Techniques for Network and Data Protection*, , pp. 1-13.
- [24] Hwang, M., Lee, C. and Tang, Y., 2002. A simple remote user authentication scheme. *Mathematical and Computer Modelling*, 36(1), pp. 103-107.
- [25] Lin, C. and Lai, Y., 2004. A flexible biometrics remote user authentication scheme. *Computer Standards & Interfaces*, 27(1), pp. 19-23.
- [26] Lee, N. and Chiu, Y., 2005. Improved remote authentication scheme with smart card. *Computer Standards & Interfaces*, 27(2), pp. 177-180.
- [27] Chang, Y., Chang, C. and Su, Y., 2006. A secure improvement on the user-friendly remote authentication scheme with no time concurrency mechanism, *Advanced Information Networking and Applications, 2006. AINA 2006. 20th International Conference on* 2006, IEEE, pp. 5 pp.
- [28] Inuma, M., Otsuka, A. and Imai, H., 2009. Theoretical framework for constructing matching algorithms in biometric authentication systems. *Advances in Biometrics*. Springer, pp. 806-815.
- [29] Lu, J., Zhang, S. and QIE, S., 2011. Enhanced Biometrics-based Remote User Authentication Scheme Using Smart Cards. *IACR Cryptology ePrint Archive*, 2011, pp. 676.
- [30] Jeon, S., Kim, H. and Kim, M., 2011. Enhanced biometrics-based remote user authentication scheme using smart cards. *J.of Security Engineering*, 8(2), pp. 237-254.
- [31] Li, X., Niu, J., Ma, J., Wang, W. and Liu, C., 2011. Cryptanalysis and improvement of a biometrics-based remote user authentication scheme using smart cards. *Journal of Network and Computer*
- [32] Hopcroft, J.E., Je rey D. Ullman. 1979. *Introduction to automata theory, languages, and computation*.
- [33] Petri, C.A., 1962. *Kommunikation mit Automaten*. Ph. D. Thesis, University of Bonn.
- [34] Peterson, J.L., 1981. *Petri Net Theory and the Modeling of Systems*. Prentice-Hall.
- [35] Murata, T., 1989. *Petri nets: properties, analysis and applications*. Proceedings
- [36] Bobbio, A., 1990. *System modelling with Petri nets. Systems reliability assessment*. Springer, pp. 103-143.
- [37] TAPAAL 2.4.3 Petri nets simulation and verification of timed-arc Petri nets. Available ar: www.tapaal.net.
- [38] Stallings, W., 2011. *Cryptography and Network Security, 5/E*. Pearson Education, Inc.
- [39] Yokoyama, V.T.V., 2000. Elliptic curve cryptosystem. *Fujitsu Sci.Tech.J*, 36(2), pp. 140-146.