

# Innovative system for delivery of low temperature district heating

Anton Ianakiev<sup>a1</sup>, Jia Michelle Cui<sup>a</sup>, Steve Garbett<sup>b</sup>, Andrew Filer<sup>b</sup>

<sup>a</sup> School of ADBE, Nottingham Trent University, 50 Shakespeare Street, NG1 4FQ, Nottingham, UK

<sup>b</sup> Enviroenergy Ltd., 12 London Road, NG2 3AB, Nottingham, UK

## Abstract

An innovative low temperature district heating (LTDH) local network is developed in Nottingham, supported by the REMOURBAN project, part of the H2020 Smart City and Community Lighthouse scheme. It was proposed that a branch emanating from the return pipe of the existing district heating system in Nottingham would be created to use low temperature heating for the first time on such scale in the UK. The development is aimed to extract unused heat from existing district heating system and to make it more efficient and profitable. The 94 low-raised flats in four maisonette blocks in Nottingham demo site have been selected to be connected to this new LTDH system. The scheme will provide a primary supply of space heating and hot water at approximately 50°C to 60°C. Innovated solutions have been put forward to overcome certain barriers, such as legionella related risks and peak loads during extreme heating seasons and occasional maintenance.

## Keywords

Low temperature district heating  
District heating expansion  
Energy efficiency Waste (unused) energy  
Renewable energy

## Abbreviations

CHP Combined heat and power  
DHW Domestic hot water  
EE Enviroenergy Ltd.  
EfW Energy from Waste  
HE Heat exchanger  
HIU Heat interface unit  
LRHS London Road Heat Station  
LTDH Low temperature district heating  
NCC Nottingham City Council  
NCH Nottingham City Homes  
SCADA Supervisory control and data acquisition system  
TRVs thermostatic radiator valves

## 1 Existing district heating network at Nottingham

Nottingham's ambition as a smart city is to reduce carbon emissions by 26 per cent and generate 20 per cent of its energy requirements from renewable and low carbon sources by 2020 [1]. The Nottingham City Council aims to create a citywide heat network that will further enable Nottingham to cope with climate change and build resilience to external energy price pressures. To speed up the process toward 20 per cent energy efficiency improvement, the huge energy-saving potential in the building sector and the expansion of existing district heating network with more energy efficient ones should be exploited [2]. The Nottingham district energy network is comprised of approximate 68km of insulated pipework carrying pressurised hot water around Nottingham City Centre and St. Ann's, a residential suburb to the north of the city. This has been used to satisfy the space heating and hot water requirements of circa 4,900 dwellings that represent a domestic market share of 42 per cent among the around 11,500 occupied dwellings in the area. In terms of commercial connections, it has previously been estimated that the district heating network represents around 20 per cent of the City's non-domestic gas consumption; the market share of commercial heat sales is around 25 per cent. Over 100 commercial premises are connected to district heating network, including the city's two main shopping centres, the National Ice Centre/Nottingham Arena, Nottingham Trent University, office developments, theatres, and various other large

---

<sup>1</sup> Corresponding author: [anton.ianakiev@ntu.ac.uk](mailto:anton.ianakiev@ntu.ac.uk)

local developments. Nottingham's extensive district heating network derives from the tradition of using incinerators to provide heat supply. The first incinerator or "Destructor" was built in Nottingham in 1874 by Manlove, Alliott & Co. Ltd. to the design of Albert Fryer.

The city is currently served by a district heating system via London Road Heat Station (LRHS) combined heat and power (CHP) plant operated by Enviroenergy Ltd., which is supplied primarily by steam generated by energy from waste incineration facility. LRHS supplies steam and medium pressure hot water and electricity to private customers; surplus electricity is sold to the Grid. The heat energy mainly comes from the annual incineration of around 170,000 tonnes of municipal waste at Eastcroft incinerator (Figure 1), which is used to create a supply of high-pressure steam, pumped directly into the LRHS. To ensure a reliable supply, back-up is provided by gas boilers, which are only operational over five to ten per cent of the time. As it is a CHP Plant, the steam is also run through a generator turbine to produce 60GWh of electricity annually. This is supplied to large commercial customers through a privately wired network, with the excess spilled to the UK National Grid.

Heating mains are rated for temperature up to 140°C at 11 bar, although normal operating temperatures range seasonally from around 85°C to 120°C and return temperature around 70°C. A brief energy balance is established from the 170,000 tons waste burned per year by assuming a relative low heating value between 2.6 and 2.8 kWh per kg waste. Between 442 and 476 GWh heat energy are produced annually. Since 375 GWh are converted to pressure steam, the remaining 67 to 101 GWh heat energy is lost to the environment by the flue gases (no flue gas condensation is applied). From the 375 GWh heat passed to LRHS, 144 GWh are used for heat distribution and 60 GWh for electricity production. This means that 171 GWh of valuable heat energy resource is unused and can be potentially recovered by various schemes like the present LTDH scheme for annual heat sales to improve the efficiency and profitability.



Figure1: Eastcroft Incinerator in Nottingham

The key environmental benefits of the low carbon fuel source using Energy from Waste (EfW), which is energy recovered from the incineration of waste, are as follows:

- EfW largely removes the requirement for Nottingham and surrounding Boroughs to landfill refuse, removing the associated emissions;
- Waste analysis data for the EfW plant indicates that around 61 per cent by weight, arises from renewable biomass media;
- Heat customers receive a far more efficient energy supply than those with gas boiler systems, as they only receive 'useful energy';
- The CHP plant integrates the production of both usable heat and power (electricity) into one single, highly efficient process. In contrast, the heat produced as a by-product of generating electricity at a traditional power station is mostly wasted;
- Enviroenergy Ltd. participates in Triad avoidance, helping the National Grid meet periods of high demand;
- The District Energy Scheme offsets approximately 27,000 tonnes of CO<sub>2</sub> emissions annually that would otherwise be produced by alternative use of gas.

Nottingham's existing district heating network using EfW is close to the REMOURBAN demo site at Sneinton. Enviroenergy Ltd. has been managing the established heat network and production for a number of decades with wide range of experiences. Therefore, the existing district heating system has the capacity to facilitate the extension and transformation of existing network to meet the requirement of low temperature district heating (LTDH).

## 2 Description of the LTDH interventions

The opportunity to use the return flow from the existing high temperature network rather than extending high temperature supply has presented Nottingham with a cheaper and effective proposition for heating residential homes without the need for high pressure, high temperature resilient infrastructure. Due to the lower flow temperature, the network heat loss will be reduced by 75 per cent compared to the present district heating systems. This makes the LTDH systems economically more sustainable and competitive for modern well-insulated, low energy buildings or significantly improved, retrofitted properties [3, 4]. The area around Sneinton Road, Sneinton of Nottingham, was considered as the most appropriate for the development of the REMOURBAN demo site as the site is very close to the existing district heating network. The network has been extended to three high-rise blocks of flats that are in the proximity of the demo area [5]. The vast majority of the residential buildings are owned by Nottingham City Council (NCC) and managed by Nottingham City Homes (NCH), the main social housing provider in the city. This makes the selection of the site for a new plant room and the associated access issues much easier. Various studies have been conducted to help identify potential new customers. Heat mapping exercises have taken place to show properties with a viable heat demand in proximity to the DH network. The LTDH intervention is planned to be implemented in the maisonettes at the Byron, Haywood, Morley and Keswick Courts (Figure 2). These four low-rise blocks of maisonettes have also been included in the REMOURBAN project refurbishment programme. Most of these properties have an individual gas boiler connected to the gas grid. Gas is used for central heating and domestic hot water (DHW), although a minority of properties are still using electric heaters. There are a minority of very poorly rated gas boilers amongst the private properties, whereas most of the NCH homes will have gas boilers rated at C or above, including one room thermostat and a programmer. Most will also have thermostatic radiator valves (TRVs).



Figure 2: Maisonettes at Morley Court

The properties of four courts have brick cavity walls; but the front of each flat is made from infill panels with timber studs covered with tiles. The floor slabs are poured concrete. Windows in NCH properties are generally double glazed due to the UK Decent Homes Investment programme. Due to the building design, the top floor windows are currently shaded by the roof overhang, whilst the bottom floor of each maisonette is situated further forward on the building line and these are therefore not shaded.

The LTDH flow will be drawn from the return pipe of the district heating mains with the medium-temperature water travelling back to the LRHS for reuse. Figure 3 shows the approximate planned route of high to low temperatures infrastructure to connect the four maisonette blocks with a total of 94 properties in the demo site to meet the demand of space heating and DHW. The LTDH will provide a primary flow temperature at approximately 50°C to 60°C and return temperature approximately at 30°C, which are much lower than usual and result in lower transmission losses.

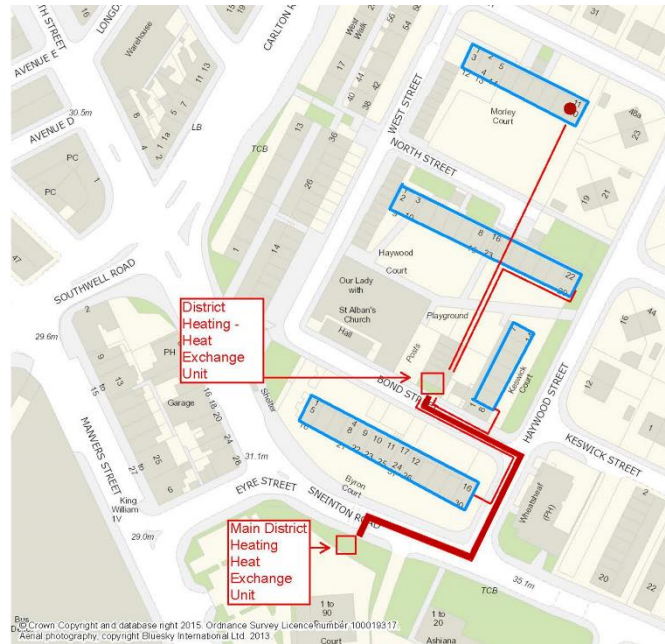

Figure 3: LTDH network planning map in REMOURBAN project

Enviroenergy Ltd. will provide a central connection point to the district heating scheme within a specially constructed central plant-room. The new pipework will form a closed loop, from / back to the primary and return mains on Sneinton Road, into a brazed plate heat exchanger within the plant-room with a virtual 100 per cent efficiency rating. The plant room will also contain additional pumping provision. Four umbilical lines, one to each maisonette block, will be run from the plant room to supply individual dwellings. The central plant-room among the blocks will reduce the transmission heat losses resulting from transporting the heated water to each block as well as simplifying the ground works and connections. The heat supplied to the LTDH scheme will be accurately metered at this central point to record heat delivered to the individual blocks and then to record accurately any losses through the internal distribution the individual dwellings. This metering will also enable Enviroenergy Ltd. to bill the scheme based on the heat supplied by the district heating network. The individual properties will have energy meters installed in each flat and will be billed separately for the heat used within each property. The transmission or storage losses will be billed to the housing provider in an additional format; these additional charges may need to be in the format of a maintenance or facilities charge.

The layout of the LTDH connection is demonstrated in diagram in Figure 4. The aim is to achieve the safe operation and optimum performance of the plant and equipment. Due to barriers such as legionella issues, it is proposed to include a shortcut connection / thermostatic injection valve from the primary flow pipe that can act as a 'top-up' for the system, should the temperature of the primary return falls below the design figure and / or the flow rate in the primary return falls below that of the low temperature connection. Under certain conditions, the primary return pipework may be raised to a temperature higher than 110°C for the utilisation of the primary return pipework as a thermal store. This situation is generally very rare (only at very cold winter period with lots of demand on the heating system) and should be avoided as it will cause low cycle fatigue of the steel pipes.

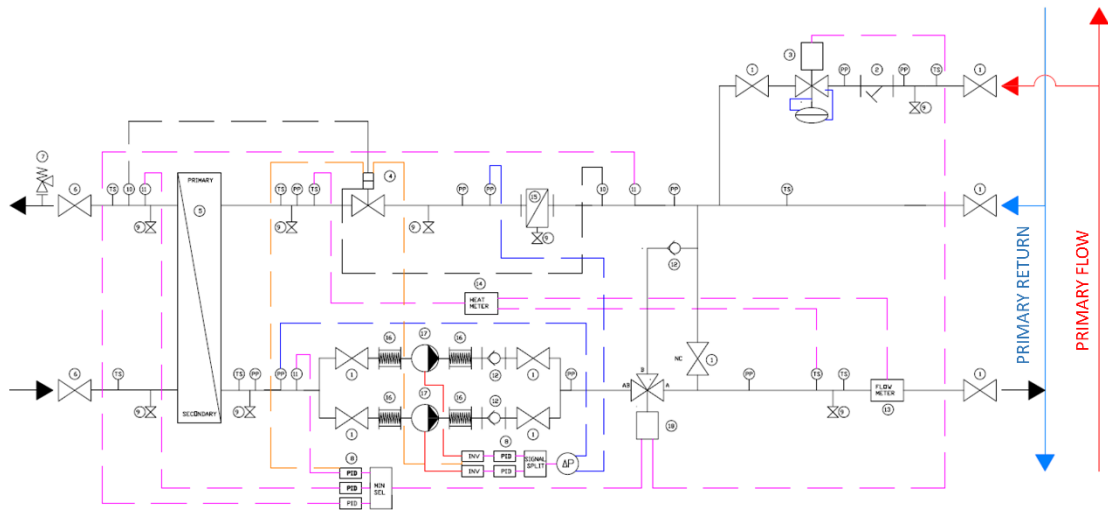

Figure 4: Schematic layout of LTDH connection to existing district heating system

The DHW will be supplied using the same flow and return that will go through a high efficiency plate heat exchanger (CALEFFI - SATK20305) that will convert Main Cold Water (MCW) into instantaneous hot water without the requirement for stored hot water within the individual properties thus mitigating any risk of Legionella. The local distribution into each property, from the central buffer vessel in each block, is proposed as follows. Within the individual blocks, the intervention would supply a low temperature flow (approximately 50°C to 60°C) that would go through class two heat meters into the individual properties and deliver low temperature heating that would be supplied into the individual rooms by zone activated control valves.

Each property will be connected to a dedicated pair of flow and return pipes. The pipework will be routed where possible within the heated envelope of the building in such a way that access to the pipework is possible for future work. Once within the property the pipework will connect to the heating and hot water distribution system via a self-contained Heat Interface Unit (HIU) within each property.

The HIU consists of a pair of plate heat exchangers and control systems along with integrated energy meters supplied by Enviroenergy Ltd. This unit will provide low temperature hot water (LTHW) to the heat distribution system and a pressurised DHW supply to the outlets within the property. The HIU provides the same functionality as the current gas boiler systems but without the need for a gas supply or flue. In the plant room, a buffer tank of 1,600 litre will be installed to deal with the peak load in the system.

The current heating distribution system will utilise the existing district heating pipework inside the building. Original thoughts on heating distribution for this project were to replace the existing standard radiators with a new innovative skirting heating system. Following a research visit to Copenhagen, Denmark and speaking with specialists from the Technical University of Denmark and SAV Ltd., it has now been decided to adapt the existing standard radiators [6-12]. Changing the flow connections to the top of the radiator rather than to the bottom as in the UK conventional connection approach will provide a more efficient system for the consumer. This will also minimise disruptions to the consumer during the works.

The heating system will be connected to the HIU via a manifold allowing each building storey to be individually controlled, further reducing energy usage. The radiator in each room in a flat will be equipped with wireless TRV, to control the load and the flow to be at certain design level in order to obtain low return temperature. In conjunction with a temperature sensor in each room an intelligent controller in each flat (developed by SASIE a local company in Nottingham) will provide individually set temperature control of each room. Individual control of the rooms on different storey will give better control and more efficient use of energy than the conventional control with a single central room thermostat.

The main barrier of LTDH is the increased risk of legionella growth in stored water at low hot-water temperatures, close to 50°C. If the water volume in each DHW supply line heat exchanger (HE) can be limited to three litres, including the water content on the secondary

side of the HE, then the system can be operated below 50°C without using external treatment or recirculation [13-15].

The existing radiators in each building where the LTDH will be implemented are generally over-designed to provide sufficient heat in very cold winter days. The buildings where the LTDH will be developed in Nottingham will undergo a retrofitting intervention. With the appropriate retrofit and improved building energy performance, the post-retrofit heat demand will be reduced and can be provided with the same size radiators heated at the new lower temperature. High heat demands under extremely cold weather conditions is in general not typical for the UK, but in such cases a gradual increase of the feeding temperature of the secondary site up to 70°C is planned to satisfy the heating demand. Industry standard was used to assume the number of occupants, their likely water usage in the proposed system. Each building was then modelled using Design Builder simulation software for heat losses, taking into account orientation, annual monthly average outdoor temperatures as well as the lowest temperatures, standard internal comfort temperatures, U values, exposed perimeters, air changes, hot water use and diversity factors. After the detailed simulations regarding the heating and DHW demand in each maisonette court, the estimate of heating load is 291.4 kW (3.1kW per property with diversity factor of 1) and the supply of DHW is 286.1kW (diversity factor of 0.088). The estimated total energy requirement after the retrofitting intervention is 998.7 MWh, which include 727 MWh for space heating and 271.7 MWh for DHW. The heating distribution system is configured to provide 100 per cent of the heating and DWH requirements of each property from the district heating. A proposed photovoltaic array would further generate approximately 82 MWh/year of electricity.

### **3 Expected results**

This intervention will give clarity on the feasibility to connect to existing district heating network and to use lower grade materials on the secondary connection at a reduced cost. If proved, this could allow Enviroenergy Ltd. to implement more connections using this connection method, based on the current hydraulic capacity of the existing infrastructure.

In this new LTDH development, the primary side of the heat exchanger (HE) is expected to have feeding and return temperatures of 70°C and 40°C respectively; and the secondary side of the HE, 60°C and 30°C respectively. There was a debate to have 55°C feeding temperature on the secondary side of the HE. However, the decision was to stick with a more conservative 60°C, which was considered as lower risk.

Based on current working practices, if low temperature technology were to be implemented, more energy may be extracted from the current network, subject to risk evaluation of available stand-by plant capacity of up to 13.5 MW. This is based on the energy available during winter period from the average primary return temperature of 70°C and the design heating input temperatures of 60°C at the flow rate of 1200m<sup>3</sup>/hr. This intervention technique could be replicated for a larger scale of retrofit on existing domestic housing estates such as the Meadows area of Nottingham, and for the planning of new developments that are in discussions to the East of the Eastcroft incinerator along the bank of the River Trent. A 3D hydraulic model on the DH network efficiency is also currently being developed to clearly show the technical feasibility of new connections.

Householders can expect to benefit from an improved internal climate with a faster heating response time, higher comfort levels (due to the more even temperature distribution) and reduced maintenance. The increased control levels will provide a better interface with the heating system allowing the user to have more control and feedback from the system to enable better utilisation of the system. Billing will be simpler for both user and provider. Energy use will be accessible remotely in real time. Users will be able to see what is being used in their property and will be able to tailor their use accordingly.

Locally, installers and the district heating network operator will be able to assess the ability to increase the efficiency of district heating by utilising the lower temperatures available on the return legs. The performance of the scheme will also be able to provide evidence for the utilisation of LTDH with the potential increases in efficiency due to a lower distribution temperature. The learning on the development of the project will prove useful; and this may lead to an implementation of buffer storage and solar thermal systems to reduce temperatures for existing properties on the district heating scheme for future extensions and the refurbishment of other non-traditional housing of the local region and beyond.

#### 4 Data collection, mapping, monitoring, and metering

A new supervisory control and data acquisition (SCADA) system will be installed at the existing heat station to connect with the sub-station for the project. The improved reports and dashboards will give relevant engineers access to real-time data. The reporting system has the following features:

- View, edit and create trends
- Real-time data dashboards
- Plant start-up and shutdown analysis
- Diurnal demand – plant performance analysis
- XY plots for performance envelope analysis
- Ability to calculate efficiencies, data mining for best performance
- Aggregation of flows, run hours etc.
- Predictive maintenance analysis

The key advantages of the new reporting system reside in its flexibility and the speed in which reports can be generated so that appropriate controls can be adjusted more quickly. The dashboards are also available through a web interface meaning that engineers can monitor systems remotely or on site as necessary. Alarms for the system can be configured and categorised more effectively.

Within each dwelling, the domestic HIU will include a heat meter connected to a user-friendly monitor – the EE Monitor (Figure 5) that is a smart and adaptable multi-functional device for use inside the home to show how much energy is being used and what it costs. Developed by Enviroenergy Ltd., the EE Monitor provides landlords and tenants with effective management, cost-benefit control over energy bills and CO<sub>2</sub> usage

The monitor gives control to the user ensuring they have the information they need to budget for and manage their energy consumption. As a prepayment device, it protects people from fuel debt as they pay for their energy usage upfront. The device has been developed with flexibility for the user as a key feature. There are multiple payment and emergency credit options to suit the needs of the household. Heat can be paid online, on the monitor itself with a credit card, over the phone, in Pay-Point outlets; and there is also a standing order facility.



Figure 5: EE monitor

The monitoring and credit control services have been developed with the needs of landlords in mind. The monitor is simple to install and easy to retrofit, with an Ethernet and a GSM solution available. With the EE Monitor landlords can have peace of mind since debt exposure is minimised; and where there is existing debt this can be recovered gradually through a debt recovery service.

The data hub of the aforementioned intelligent controller, which will be developed by SASIE in Nottingham, will be installed in some flats served by LTDH to handle the data collection and transmittal of the property data. The data hub is based on a Linux based mini-computer that will act as the interface between the component parts of the system. The Linux OS was chosen on the basis of the open source nature and the facility to use peripherals from various manufacturers that are designed to work with this platform.

The data collection and monitoring peripherals will use a variety of wireless standards to allow communication between the individual components and the controller. Wireless communication was proposed based on the retrofit nature of the work. The installation of hardwired connections between the individual components was determined to be more expensive and disruptive. The data hub will be fitted with modules to allow connections using Wi-Fi, ZigBee and Lo-Ra. This will allow the peripherals to be sourced from a large range.

The data that will be collected from the property for monitoring and control purposes are as follows.

- Room temperature and relative humidity: the sensors within the room-based unit will convert the readings into a signal that is readable and transmittable by the controller. A sensor will be placed within each habitable room. The recorded actual temperatures allow the controller to regulate the performance of the system. This will allow monitoring of heat loss relative to the local weather and can be used to monitor the heating usage in the property.
- Heat Energy: data will be collected from the heat meters installed on the heating and hot water systems that will allow billing and also determine the temperature and flow rate of LTDH water used within the property.
- Electricity Consumption: the electrical usage within the property will be monitored using a combination of electricity meters and CT clamp before a local smart metering scheme is rolled out.

The data hub will also be fitted with Ethernet and Wi-Fi connections to allow it to communicate with the Nottingham Trent University monitoring server. The data centralised at the server side will be utilised in the proposed energy mapping and third-part mobile APP and gaming development to further enable energy savings and citizen engagement.

## **5 Innovation in community engagement**

NCH and NCC will run a targeted engagement process for the tenants in the four low-rise blocks of maisonettes courts. The aim of the communications is to:

- increase awareness, understanding and good will towards the works to the tenants;
- increase awareness and understanding of the project to the tenants;
- ensure that tenants can efficiently use new heat system;
- increase awareness of Sneinton being part of a wider project with regards to low carbon housing and transport.

Before the works start, a research on tenant demographic will be conducted to produce appropriate direct mails materials and to develop an informing pack. Direct mails to households and a series of letters to tenants are expected to inform them about the works and to work with them to secure convenient dates. The local influencers, including Councillors, Member of Parliament, tenant groups, community groups, Neighbourhood Development Officers, need to be informed. Citizen engagement will be much improved by the visits to assess customer services and to disseminate information pack. Open Days will be organised for the tenants who are to receive the works to meet contractors. Posters will be developed for communal places to advertise the scheme. NCH Local Area Newsletters will be issued to celebrate the project for the tenants and to help increase awareness and goodwill. Phone calls will be conducted the day before to remind tenant of the works plan agreed.

During the works, it is essential to conduct NCH liaisons with tenants and the contractors to ensure smooth channels of communication and to deal with any issues that may arise, to disseminate user guides for tenants on how to use the new technology and on how to be more energy efficient, and to collect marketing collateral – photos, case studies.

After the works, it is important to conduct customer satisfaction survey, to follow up customer care visits to ensure people know how to use the new technology, and to organise event to celebrate the project completions.

Before, during and after the LTDH implement and commissioning, street advertising and tours of the incinerator / heat station for the new customers will be organised to see the full waste joinery in Nottingham. A series of dates will be set depending on demand.

## **6 Conclusions**

The LTDH development in Nottingham supported by REMOURBAN H2020 project utilises a heat supply from the return pipe of the existing DH system in Nottingham. It is aimed to extract unused heat from existing systems and to make it more efficient and profitable. The Nottingham district heating system has extra thermal capacity that can be extracted without affecting the hydraulic capacity by using the return pipe option.

The LTDH development will prioritise the end users' demand, such as what thermal comfort they need. It aims to find the most economical way to satisfy these needs through efficient distribution networks and energy sourced from the wasted heat. Intelligent control will be



embedded in all LTDH associated stages, from the generation and distribution to the substation and end-user metering.

In order to maintain high efficiency of the network, it is important to achieve consistently low return temperature and high  $\Delta T$ , which will reduce the volume flow rates leading to smaller pipes and lower costs. Maintaining low return temperatures under part-load conditions is important to keep heat losses and pumping energy low. Achieving low return temperatures starts with correct adapting and balancing radiators. The implementation of LTDH requires more precise system design and has to be accompanied with interventions aiming to improve the building fabric in order to reduce the building heating demand.

A 'top-up' shortcut from the primary flow mains of the existing district heating connection will be included to act as a temperature boost for the supply water in this project. This will mitigate the risk of flow water temperature being below the required temperature. The design of the secondary system within each dwelling will have minimal stored water capacity limited to three litres. This means the system can be operated below 50°C without the requirement of external treatment or recirculation. In addition, a renewable microgeneration from photovoltaic arrays is proposed to generate approximately 82 MWh/year of electricity to sustain power demand of the four maisonette courts (Byron, Keswick, Haywood, and Morley Courts).

The REMOURBAN project provides the opportunity to set up the first substantial LTDH scheme in the UK with an innovative community and citizen engagement scheme throughout the project span. The collected data regarding the system performance will be potentially used for the energy mapping services and third-party mobile APP and gaming development. The application of the 4<sup>th</sup> generation district heating in Nottingham is expected to achieve the technical, economical and sociological impact in a long run.

### Acknowledgments

The authors would like to acknowledge the financial support of this research provided under the REMOURBAN project that is supported by the EU Horizon 2020 research and innovation programme under grant agreement No 646511.

### References

- [01] Public Sector Energy, Project Showcase: Nottingham City Council. <http://www.publicsectorenergy.co.uk/project-showcase/150-articles/project-showcase/465-project-showcase-nottingham-city-council>.
- [02] European Commission, *Directive on energy efficiency* (amending Directives 2009/125/EC and 2010/30/EC and repealing Directives 2004/8/EC and 2006/32/EC. 2012/27/EU). European Commission. <https://ec.europa.eu/energy/en/topics/energy-efficiency/energy-efficiency-directive>.
- [03] The Chartered Institute of Building Services Engineers (CIBSE), *Heat Networks: Code of Practice for the UK*. CIBSE and Association for Decentralised Energy (ADE); 2015. <http://www.cibse.org/Knowledge/knowledge-items/detail?id=a0q200000090MYHAA2>.
- [04] Rosa, D. A., Li, H., Svendsen, S., Werner, S., Persson, U., Ruehling, K., Felsmann, C., Crane, M., Burzynski, R. and Bevilacqua, C., Annex X Final Report: Towards 4th Generation District Heating - Experience and Potential of Low-Temperature District Heating. IEA DHC/CHP; 2014. [http://energia.fi/sites/default/files/iea\\_annex\\_x\\_final\\_report\\_2014\\_-\\_toward\\_4th\\_generation\\_district\\_heating.pdf](http://energia.fi/sites/default/files/iea_annex_x_final_report_2014_-_toward_4th_generation_district_heating.pdf)
- [05] REMOURBAN project, EU Horizon 2020 research and innovation programme under grant agreement No 646511. [www.remourban.eu](http://www.remourban.eu)
- [06] Brand, M. and Svendsen, S., Renewable-based low-temperature district heating for existing buildings in various stages of refurbishment. *Energy*, 62 (2013) pages 311–319. <http://dx.doi.org/10.1016/j.energy.2013.09.027>.
- [07] Olsen, P. K., Christiansen, C. H., Hofmeister, M., Svendsen, S. and Thorsen, J.-E., Guidelines for Low-Temperature District Heating. 2014. <https://goo.gl/YvYc5x>.
- [08] Lund, H., Werner, S., Wiltshire, R., Svendsen, S., Thorsen, J.E., Hvelplund, F. and Mathiesen, B.V., 4th Generation District Heating (4GDH). Integrating smart thermal grids into future sustainable energy systems. *Energy*, 68 (2014) pages 1–11. <http://dx.doi.org/10.1016/j.energy.2014.02.089>
- [09] Christiansen, C. H., Rosa, A. D., Brand, M., Olsen, P. K. and Thorsen, J. E., Technical paper results and experiences from a 2-year study with measurements on low-temperature DH system for low energy buildings. The 13<sup>th</sup> International Symposium on District Heating and Cooling; 2012. [http://heating.danfoss.com/PCMPDF/VFHZC102\\_results-and-experiences\\_lores.pdf](http://heating.danfoss.com/PCMPDF/VFHZC102_results-and-experiences_lores.pdf)

- [10] Tol, H. I. and Svendsen, S., Improving the dimensioning of piping networks and networks layouts in low-energy district heating systems connected to low-energy buildings: A case study in Roskilde, Denmark. *Energy* 38 (1) (2012), pages 276–290. <http://dx.doi.org/10.1016/j.energy.2011.12.002>.
- [11] Tol, H. I. and Svendsen S., A comparative study on substation types and network layouts in connection with low-energy district heating systems. *Energy Convers. Manag.* 64, (2012) pages 551–561. <http://dx.doi.org/10.1016/j.enconman.2012.04.022>.
- [12] Brand, M., Thorsen, J. E. and Svendsen, S., Numerical modelling and experimental measurements for a low-temperature district heating substation for instantaneous preparation of DHW with respect to service pipes. *Energy*, 41 (1), (2012) pages 392–400,. <http://dx.doi.org/10.1016/j.energy.2012.02.061>.
- [13] The Chartered Institute of Building Services Engineers CIBSE, Minimising the risk of Legionnaires' disease. 2013. <http://www.pendred.com/wp-content/uploads/CIBSE-TM13-Minimising-the-Risk-of-Legionnaires-Disease-NEW-2013-3.pdf>.
- [14] Health and Safety Executive (HSE), Legionnaires' disease: the control of legionella bacteria in water systems. 2013. <http://www.hse.gov.uk/pubns/books/18.htm>.
- [15] Health and Safety Executive (HSE), Legionnaires' disease. Part 2: The control of legionella bacteria in hot and cold water systems. 2014. <http://www.hse.gov.uk/pubns/priced/hsg274part2.pdf>