

A Low Cost Domestic Rainwater Harvesting Tank

RP de Silva¹, SA Ariadurai², HGPA Ratnaweera², MA Lambious²

¹Faculty of Engineering, Kingston University, London, KT1 2EE, UK.

²Faculty of Engineering Technology, The Open University of Sri Lanka, Nawala, Nugegoda 10250, Sri Lanka.

Abstract

This paper describes a low cost roof rainwater harvesting tank, constructed and tested at three locations in the dry and wet zones of Sri Lanka to study the feasibility of such tanks in solving acute domestic water shortage. The cost is about RS 5400 (~£20 in 2007), but can be brought even lower (to about Rs 2600 or ~£12) by using the locally available materials and labour during construction. The tank uses bamboo as a reinforcing material and polypropylene as a water proofing membrane, both of which are available locally in any village. The low level technological input requirement was a design requirement, in addition to low maintenance. During a two year monitoring period, the tanks performed well and it is anticipated that, with correct use and maintenance, a design life of about 5 years could be achieved.

Keywords

Domestic rainwater harvesting, low cost, Sri Lanka

Introduction

People are realising the importance of harvesting rainwater at domestic level for their water requirements as;

- other water sources may simply be not available or uneconomical to be tapped;
- quality of rainwater is often good enough for most domestic and irrigation water requirements (and even for drinking after boiling);
- saving of time which could be put to other useful work if water is available nearby especially in some developing countries where people (often women and children) have to walk for many miles daily to meet the essential water requirement;
- low cost solutions are available for collecting the rainwater from roofs.

Several countries like Honduras (Reyes, 1997), Grenada (Peters, 2006), Singapore and India (Thomas, 1998), Greece (Sazakli, 2007), East Africa (Rees at al, 2000), Botswana, Japan, Germany, USA (UNEP, 2002) have reported work on rainwater harvesting (RWH) at least as a supplementary source of water. Harvesting rainwater is practised, often using large reservoirs at ground level. In Sri Lanka the government considered water provision for its people a top priority, resulting in river diversion schemes and development of the groundwater resource. This resulted in taking the emphasis away from rainwater harvesting at a domestic level, but, factors such as an increasing population, unreliability of other water sources and high suitability of RWH (especially for certain areas) along with the ones mentioned above have ensured a comeback for RWH, in the last 10-15 years.

This paper describes the construction of a very simple domestic RWH (DRWH) tank to collect roof harvest in each household in Sri Lanka. The design suits the poor sector of society and uses locally available material and labour without the need for any advanced technological inputs.

This tank was designed for the dry areas of Sri Lanka where any of the water supply schemes still have not effectively met even the basic water requirement. Often very poor people live in such places and mere availability of water would make a significant change in their lives as it would help not only their domestic water requirement including drinking, but also the requirements of any small scale irrigation. The visits to these areas show that the type of water these people often are compelled to drink are of very low quality and often the harvested rainwater would be of better quality even if drunk without boiling. Figs. 1 and 3 show typical coconut frond thatched houses of the rural poor and Fig. 2 shows raw coconut leaves being woven.



Fig. 1: A coconut frond thatched roof [Source: <http://www.peacegallery.org/images/asia/srilanka/srilanka07.JPG> (accessed 04 May 2007)]



Fig. 2: Weaving a coconut frond [Source: <http://www.kamat.com/indica/culture/eco-friendly/5128.jpg> (accessed 04 May 2007)]



Fig. 3: A coconut frond thatched roof where rainwater is collected in a tank using indigenous wooden gutters [Source: Lanka Rainwater Harvesting Forum]

Materials and Methods

After carrying out a number of simple experiments, the following design (Figs. 4 and 5) was constructed and tested. The volume of the tank is 3.0 m³ and is trapezoidal in vertical section. Optimum tank size requires the collection of several parameters such as rainfall, water consumption and materials (Chao and Yao, 2004). Many farmers

will be unaware of these values and therefore a single size tank was selected as the simplest design. Also since the water is used mainly for drinking this capacity is adequate, even during dry periods. The dwelling roofs are either coconut frond thatched or asbestos sheeted with an average size of about 25 m².

In constructing the tank, a pit of the size shown in Figs. 4 & 5 is dug first. The bottom of the tank and sides are tamped to stabilize the soil. After this, a polypropylene sheet (gauge 500 or 125 x 10⁻⁶ m thick) which can be joined easily with a household hot iron (used for ironing clothes and available even at remote villages) is very carefully laid as the outermost layer of the tank, ensuring that punctures are not made in the polypropylene sheet. Next a bamboo reinforcement (each strip 25-40 mm wide and at 150 mm spacing joined with steel binding wires) as shown in Fig. 4 and in the photographs in Fig 7, is placed carefully at the bottom and sides, and the tank is plastered with a cement:sand mixture of 1:12. This 1:12 ratio was experimentally determined in the laboratory where tests show that ratios higher than this resulted in the plaster dissolving in water with time. Also in-situ soil (instead of sand) can be used which will reduce the cost, unless the soil is of very poor quality. Three tanks were constructed for this experiment, with in-situ soil used instead of sand.

After plastering, the top of the tank (which is about 150 mm above the ground level) is constructed with 2-3 rows of bricks (Fig. 4) and overflow and outlet pipes fixed. Lastly a suitable cover (in these cases asbestos sheets were used) is added. The tank is carefully cured before allowing rainwater to collect.

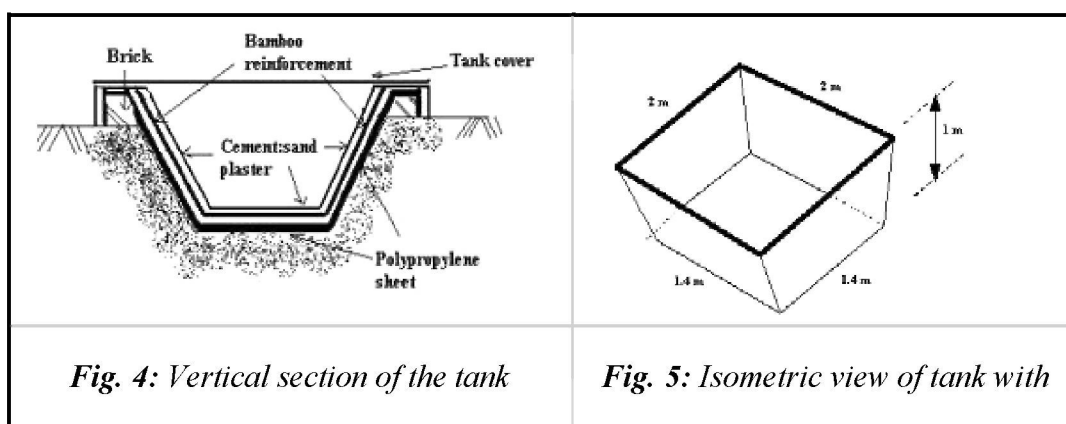

The shape of the tank was chosen for ease of excavation, making the bamboo reinforcements, making and joining polypropylene liner and plastering the inside of the tank.

The locations used to construct tanks for testing were Madurankuliya, Nawala and Embilipitiya (shown in Fig. 5) in the wet and dry zones of Sri Lanka. Details of site locations are given in Table 1.

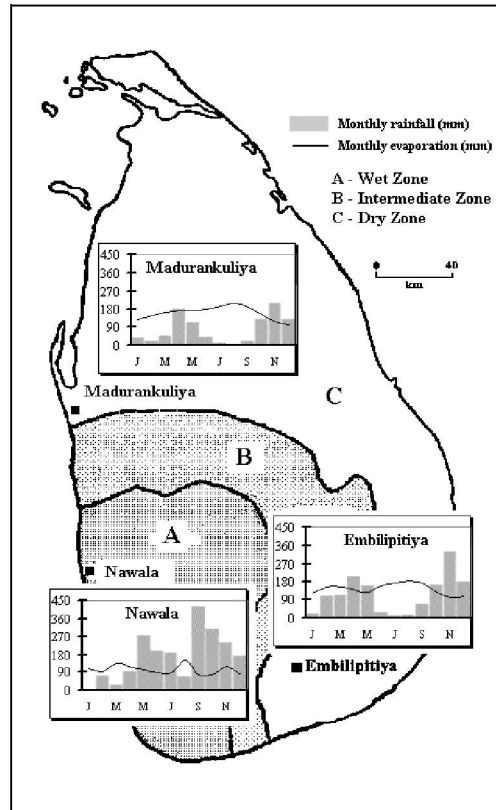

Fig. 6: Study locations (shown as dark squares) along with the climate for the location (major rainfall zones for Sri Lanka are also shown).



Fig. 7: Some Photographs showing various stages of construction of the tank.

Location Name	Mean Annual Rainfall (mm)	Mean Annual Pan evaporation (mm)	Soil type	Remarks
Madurankuliya	950	1935	Silty sand	Near a peasant house. Depth to water table 10 m.
Nawala	2047	1217	Loamy clay	Site location near a stream. Water table rather high in the ground (depth about 2 m). Comes up when canal flows full.
Embilipitiya	1380	1707	Clay (Filled and compacted on previously marshy land)	Near a farm house with water table >4m deep, salinity in water

Table 1: Details at Study Locations

Results

The tanks were constructed (some photographs taken during construction are shown in Fig. 7) in April-May 2001 and have been in use for about two years (at the end of the monitoring period). The current statuses of the tanks are as indicated in Table 2. As seen, tanks at Madurankuliya and Nawala are performing well. The failure of the tank at Embilipitiya was caused by improper use of the tank by the farmers (ie using a steel bucket to draw water with heavy impact loads on the sides of the tank), where they have re-plastered the tank with 1:6 cement mortar. During this process the polypropylene sheet had been punctured and a leak ensued. However, up to then the tank performed well over a one year period. In addition the side of the tank close to a stream of the Nawala tank caved in during heavy rain where the water level in the stream rose sharply. Lateral forces caused by hydraulic pressure caused this cave in. Unfortunately the tank had been nearly empty and the gutter system was not directing water in to the tank. However, if the tank was full, or if the gutter system was operational, the cave in could have been avoided.

	Madurankuliya	Nawala	Embilipitiya
Repairs done	None	None (except propping up the tank from inside)	Walls were plastered by users
Termite attacks observed	None	None	None
Any aquatic plant growth or fungus growth inside the tank	None	None	None
Condition of Tank wall	Not collapsed/ not dissolved	Not collapsed / not dissolved	Not collapsed/ not dissolved

Possible leaks from tanks	None	None	Observed from one feet above the bottom
New cracks			
Bottom of the tank	None	None	None
Tank wall	None	None	None
Bricks wall	None	None	None
Quality of water			
Appearance.	Clear	Clear	Unsatisfactory
Taste	OK	OK	
Smell	OK	OK	Bad
Present situation	Satisfactory and can be used further more	Satisfactory and can be used further more	Abandoned

Table 2: Status of the 3 tanks constructed as at Oct 2003

Discussion

The use of untreated bamboo as reinforcement might cause problems over time. However, up to the two years the tanks were in service, no deterioration of bamboo or structural failure resulting from deteriorated bamboo was reported. Also care should be taken in using chemicals such as copper-chrome-boron (CCB) to treat bamboo, which can be harmful especially if the tank water is used for drinking.

Table 3 shows a comparison of the tank built for this experiment with some other low cost tanks documented. As seen, the design suggested in this study has many advantages. Comparatively low cost, the non-involvement of advanced technology and low maintenance requirements are some of them. In fact the cost can be made very low (Rs 2600) if labour and materials can be sourced from local villages. The cost can be lowered further if low cost covering material is used as this is the most expensive item (as in many other tank designs).

The drawbacks include the low factor of safety of the design and use of untreated bamboo (which may not last for more than 7 years as shown in a study in Botswana). Since the weight of the tank is less, it is liable to be subjected to uplift forces from groundwater and care must be taken to ensure that the tank is filled before the groundwater level rises in the vicinity. This is normally the case as down pipes from the roof are always carrying water to the tank first, unless they are wilfully diverted. Also it's important that a proper site is selected for constructing the tank. In selecting the site one must look for locations with stable soil (or even sandy soils with a bit of clay / silt), away from water logged areas and not in filled land.

The tank's design life is expected to be about 5 years. In Madurankuli area a farmer spends about Rs 1000 a month on domestic water requirements (including transportation of water). So by having this type of tank, the saving he will make over 5 years will be Rs 55,000, in addition to the time saved looking for water and arranging transport. In fact with fast depleting fresh water resources, the utility value of this type of a tank will be much higher.

Tank type	Location	Volume (m ³)	Cost [#] (SL Rs)	Remarks	Source
Pumpkin Tank	Badulla, Sri Lanka	5.0	7341.5	Made of ferrocement, requires skilled labour, in use for > 3 years	DTU (2007)
Brick Tank	Kandy, Sri Lanka	3.0	Not given	Made of brick & cement mortar, requires skilled labour, in use for >10 years	DTU (2007)
Brick dome tank	Badulla, Sri Lanka	5.0	8245	Based on the Chinese biogas digester, skilled labour required	Ariyananda (1999)
Free standing Ferro-cement tank	Badulla, Sri Lanka	5.0	10175	Very similar to Pumpkin tank above, requires skilled labour	Ariyananda (1999)
Partially below ground (PBG) tank	Ethiopia Sri Lanka Uganda	3.0	5700	Requires somewhat skilled labour	Martinson et al (2002)
		5.0	6550		
		7.0	7900		
		10.0	8900		
Wattle & daub tank	Ethiopia Sri Lanka Uganda	1.25	4414	Walls need to be 15-20 cm thick, max capacity about 5 m ³ . Requires skilled labour	Martinson et al (2002)
		2.0	4850		
		3.5	5384		
		5.0	5820		
Brick Jar Ferro-cement Jar Plastic tube jar	Uganda	0.75	7100	Skilled labour required. High per litre cost.	DTU (2007)
		0.5	6000		
		0.6	4300		
Polypropylene lined -Bamboo reinforced tank (this study)	Madurankuliya, Nawala, Embilipitiya, Sri Lanka	3.0	5370 ⁺	Requires somewhat skilled labour, Costs can be further reduced (to about Rs 2610) if materials (bamboo and bricks) and labour are found locally, extreme care necessary not to puncture the polypropylene liner	This paper

Table 3: Comparison of costs with other low cost tanks documented. # For converting costs, 1 GBP (£) = 215 Sri Lankan Rupees (Rs.) as at April 2007. +The Rs 5370 in the tank under consideration is made up as follows. Bamboo strips = Rs. 400.00, Cement = Rs. 700.00, Polypropylene sheets (10 m) = Rs. 450.00, Bricks = Rs. 260.00, Asbestos sheets = Rs. 1300.00, Steel wires = Rs. 50.00, Labour = Rs. 2210.00 (2004 prices)

Therefore it is evident that the tank designed has been performing satisfactorily for the two years it was monitored. Though further testing is necessary, the tank appears to be a suitable RWH tank for the rural setting, especially that of Sri Lanka. If adequate care is exercised in selecting a suitable site and during construction, the tank suggested in this paper is expected to give trouble free service for at least five years.

References

- Ariyananda, T (1999). Rainwater harvesting for domestic use in Sri Lanka, 25 th WEDC conference, Addis Ababa, Ethiopia.
- Chao, H. L. and L. T. Yao. (2004). Optimum Storage Volume of Rooftop RainWater Harvesting Systems for Domestic Use. Journal of the American Water Resources Association, Volume 40: 901 – 912
- DTU (2007) – Development Technology Unit, Warwick University, UK
[<http://www.eng.warwick.ac.uk/DTU/rwh/index.html> (accessed 25 April 2007)]
- Martinson D, Ranatunga N and Gunaratne, A (2002). Reducing rainwater harvesting system cost, 28 th WEDC conference, Kolkata, India.
- Peters, E. J. (2006). Rainwater potential for domestic water supply in Grenada. Proceedings of the Institution of Civil Engineers – Water Management, Vol 159: 147 –153
- Rees, D. G., S. Nyakaana & T. H. Thomas (2000) Very-Low-Cost Roofwater Harvesting in East Africa, Development Technology Unit, School of Engineering, University of Warwick, UK
- Rees, Dai (2001). Low-cost rainwater harvesting, Footsteps, no. 46, p. 10-12
[<http://tilz.tearfund.org/Publications/Footsteps+41-50/Footsteps+46/Low-cost+rainwater+harvesting.htm> (accessed 25 April 2007)]
- Reyes, E. B. (1997) Rainwater Harvesting in Honduras, In: Source Book of Alternative Technologies for Freshwater Augmentation in Latin America and the Caribbean, International Environmental Technology Centre, United Nations Environment Programme, Unit of Sustainable Development and Environment, General Secretariat, Organization of American States, USA.
- Szakli, E., A. Alexopoulos and M. Leotsinidis (2007). Rainwater harvesting, quality assessment and utilization in Kefalonia Island, Greece, Water Research 41: 2039 – 2047.
- Thomas T. (1998) Domestic water supply using rainwater harvesting. Building Research & Information, Volume 26, Issue 2: 94 – 101
- United Nations Environment Programme (2002). Rainwater Harvesting And Utilisation, International Environmental Technology Centre, United Nations Environment Programme, Unit of Sustainable Development and Environment, General Secretariat, Organization of American States, USA.

Acknowledgement

This study was funded by the **Lanka Rainwater Harvesting Forum** at No: 247, Wijaya Kumaratunge Mawatha, Kirulapone, Colombo 5, Sri Lanka and the initial findings were presented at The 4th Symposium on Domestic Roof water Harvesting in the Humid Tropics, Colombo, Sri Lanka in 2001.