

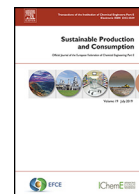

Contents lists available at ScienceDirect

Sustainable Production and Consumption

journal homepage: www.elsevier.com/locate/spc

Research article

Sustainable product development and service approach for application in industrial lighting products

Shuyi Wang^a, Daizhong Su^{a,*}, Ming Ma^b, Wentao Kuang^b^a School of Architecture, Design and the Built environment, Nottingham Trent University, 50 Shakespeare Street, Nottingham, NG1 4FQ, UK^b Kosnic Lighting Ltd, Unit D2 Kennetside, Bone Lane, Newbury, Berkshire, RG14 5PX, UK

ARTICLE INFO

Article history:

Received 21 November 2020

Revised 31 March 2021

Accepted 4 April 2021

Available online 6 April 2021

Keywords:

Sustainability

Product development

Product service

Sustainable design and manufacture

Life cycle assessment

Lighting product

ABSTRACT

Achieving triple bottom lines (TBL) throughout a product's life cycle is important in sustainable products and services. However, existing studies address the aspects of TBL partially, considering only a few stages of the product life cycle. Therefore, we propose a sustainable product development and service (SPDS) approach to address the entire product life cycle in two phases, namely product development and service phases. The former comprises product design and manufacturing stages, whereas the latter involves multiple stages, such as product distribution, retail, use, maintenance, and end-of-life. The two phases connect and interact logically to attain the TBL. The proposed SPDS approach was used to develop a sustainable industrial LED lighting product and service that exhibited prominent environmental, social, and economic performances. The environmental impact of the new product was 46% lower than that of the existing product with the same light output. Additionally, cost savings increased up to 14% per year with the leasing service, which promotes workers' welfare, reduces cost for the manufacturers, and generates a healthy recurring profit stream. Thus, the application of the novel SPDS is innovative and highly beneficial.

© 2021 The Authors. Published by Elsevier B.V. on behalf of Institution of Chemical Engineers. This is an open access article under the CC BY license (<http://creativecommons.org/licenses/by/4.0/>)

1. Introduction

The increasing demand for sustainable products has prompted multiple researchers to enhance the sustainability of products and services. Typically, product sustainability is measured using three dimensions, namely environmental, social, and economic impacts, which are referred to as the triple bottom lines (TBL) of sustainability (Elkington, 1997). To obtain sustainable products and services, the TBL must be implemented throughout the product life cycle. Therefore, we propose a sustainable product development and service (SPDS) approach that addresses the entire product life cycle through two phases. The product development phase includes the product design and manufacturing stages, whereas the product service phase handles various stages, such as product distribution, retail, use, maintenance, and end-of-life (EoL). The two phases connect logically and interact effectively based on the proposed methods of design for service (DfS) and service feedback for design improvement (SfD). This interaction between the two

phases advances the sustainability performance, which is demonstrated by the application of the proposed approach to a lighting product.

The lighting industry is a high resource-consuming sector that requires 18% of the overall electricity. Moreover, commercial lighting accounts for seven-tenths of electrical consumption (Statista, 2013). Presently, lighting accounts for 5% of global greenhouse gas emissions, which is more than double that of global air travel. Furthermore, a 50% increase in lighting demand with 50% less energy consumption is intended to be achieved by 2030 in comparison with the present scenario (Clean Energy Ministerial, 2021). Therefore, in accordance with the key Sustainable Development Goals of the United Nations, ensuring product efficiency and longer lifetime through the implementation of a circular economy and efficient materials is the emerging trend in the lighting industry.

In this regard, the SPDS approach is applied to the development of an industrial LED lighting product and service. The developed lighting product has several sustainable features, such as an innovative modular design enabling convenient repair, recycling, and reuse, ultra-high efficiency, and long service life. The combined sustainable development and service of the lighting product significantly reduces the cost for the consumers with its environmen-

* Corresponding author.

E-mail addresses: shuyi.wang2015@my.ntu.ac.uk, alice.399@hotmail.com (S. Wang), daizhong.su@ntu.ac.uk (D. Su), ming.ma@kosnic.com (M. Ma), wentao.kuang@kosnic.com (W. Kuang).

tal and socio-economic benefits. To the best of our knowledge, no such sustainable industrial product development and service bundle is available thus far. Therefore, it is a novel approach with potential innovative applications in the lighting product sector.

The existing research in this field address the aspects of the TBL partially, considering a limited number of stages in the product life cycle. Therefore, the proposed SPDS approach addresses all three sustainability dimensions in the product development and service phases, considering the entire product life cycle.

The remainder of this paper is organized as follows. [Section 2](#) reviews the relevant literature, which presents the latest developments in the field and the existing shortcomings that are addressed by this study. [Section 3](#) describes the SPDS approach in detail. Its application in the development and service of an industrial LED lighting product is presented in [Section 4](#) followed by a discussion of the implementation and limitations of the study. Finally, [Section 5](#) summarizes the conclusions of this study.

2. Literature review

The product development stage is crucial because most product-related environmental impacts are formulated during the design stage ([He et al., 2020](#); [EU Science Hub, 2018](#)). Sustainable design is an interdisciplinary concept, wherein new products are created to generate value and innovation to meet the consumers' needs by maintaining a balance between the environmental, social, and economic perspectives ([Clark et al., 2009](#)). Over the years, various methodologies and tools have been proposed for sustainable product designing ([Stoffels et al., 2018](#); [Zhang et al., 2020](#)). However, the existing studies on sustainable product development consider a single or partial aspect of sustainability, ignoring the TBL ([Onat et al., 2017](#)). Furthermore, several issues in the existing sustainable design methods and traditional product-sale models restrict the advancement of the TBL of sustainability ([Stahel, 2001](#)). Therefore, systematic approaches that address TBL during the sustainable product development stage are required ([Gbededo et al., 2018](#); [Malek and Desai, 2020](#); [Salari and Bhuiyan, 2016](#)).

The environmental sustainability of products was addressed in the late 1990s. Several methodologies, such as Green Design ([Dowie, 1994](#)) and eco-design ([McAloon and Bey, 2009](#)) have been proposed, which formed the theoretical basis for sustainable design. Initially, life cycle assessment (LCA) methodology was used in the environmental engineering field, which was subsequently introduced to the field of product designing by the Society of Environmental Toxicology and Chemistry ([Fava et al., 1991](#)) and International Organization for Standardization ([ISO, 2006](#)) to determine the environmental life cycle of the products and services. LCA serves as an evidence-based reference in several decision-making aspects, such as choosing materials and design concepts, eco-labelling schemes, and environmental declarations ([Baumann and Anne-Marie, 2004](#); [ISO, 2006](#)), during sustainable product development.

Existing sustainable methods and tools include eco-friendly material selection and assessment methods ([Zarandi et al., 2011](#), [Sakundarini et al., 2013](#); [Andriankaja et al., 2015](#)), product development innovation based on integrated eco-design tools ([Zhang et al., 2015](#); [González-García et al., 2012](#)), and tools that support decision-making and provide evaluation criteria for sustainable designs ([Salari and Bhuiyan, 2016](#); [Heintz et al., 2014](#)). However, the sustainability issue is addressed from an environmental perspective alone, and the socio-economic aspect of sustainability is not considered sufficiently ([Onat et al., 2017](#)). A recent review ([Kravchenko et al., 2019](#)) shows that merely 16% of sustainability-related indicators address social performance, whereas 61 and 23% measure environmental and economic performances, respectively.

A similar pattern is observed in sustainable manufacturing as the product design impacts the manufacturing processes significantly ([He et al., 2020](#)). Therefore, a systematic approach to address the holistic sustainability issues must be developed ([Salari and Bhuiyan, 2016](#)).

Furthermore, a product service system (PSS) combines marketable product and services to fulfil specific consumer needs ([Goedkoop et al., 1999](#)). It integrates aspects from the physical product side (goods) with an intangible service offering, such as after-sale services that include maintenance, repair, and EoL services. Typically, the service is based on specific products and has a high potential to facilitate sustainable production and consumption while ensuring customer satisfaction ([Tukker and Tischner, 2006](#)). Additionally, studies have proved that PSS can effectively achieve environmental sustainability and generate socio-economic benefits ([Mont, 2002](#); [Roy, 2000](#)).

[Maxwell and van der Vorst \(2003\)](#) introduced a method to develop sustainable products and services. Their method was developed based on existing concepts and tools to address the sustainability of products and services of enterprises. [Vezzoli et al. \(2014\)](#) proposed the PSS design for sustainability, wherein they reported that bridging the connection between sustainable consumption and innovation beyond the product was crucial to enhance the sustainability radically. [Chou et al. \(2015\)](#) introduced the concept of sustainable product-service efficiency to explore the sustainability impacts on PSS. Moreover, several other frameworks and tools were proposed for sustainable PSS ([Manzini and Vezzoli, 2003](#); [Lumsakul et al., 2018](#)). However, researchers tend to explore the service based on an established product considering the economic perspective. Consequently, sustainable product design and manufacture aspects have not been investigated sufficiently.

Although numerous studies addressed the environmental aspects of lighting products ([Tähkämö et al., 2012](#); [Principi and Fioretti, 2014](#); [Wang et al., 2020](#)), they compared the environmental impacts and energy efficiencies of different technologies of LED lighting products. However, only a few researchers considered the product development and service in terms of the combined impacts of environmental, social, and economic aspects.

Thus, most existing studies focus on one or two sustainability dimensions of TBL, whereas all three dimensions are rarely considered. Therefore, to obtain a holistic view of the three sustainability dimensions, we developed the SPDS approach by integrating the product development and service phases and demonstrated its effectiveness by applying the proposed method to an industrial LED lighting product.

3. Methods

3.1. The SPDS approach

The proposed SPDS approach aims to support sustainable innovation throughout the life cycle of the product. It reduces environmental burdens, addresses social issues, and achieves competitive economic interests of the providers. As illustrated in [Fig. 1](#), the SPDS approach involves all stages in the product life cycle, including the product design, manufacture, distribution, retail, use, maintenance, and EoL. The design and manufacturing stages are covered by the sustainable product development phase, and the remaining stages are considered under the sustainable product service phase. The approach is supported by various techniques and tools, such as LCA, methods for interaction between the two phases, sustainable design and manufacture, and leasing services, which are detailed in the subsequent subsections.

Although the SPDS approach is a life cycle thinking (LCT) and life cycle management (LCM) ([UNEP/SETAC, 2009](#)) framework sup-

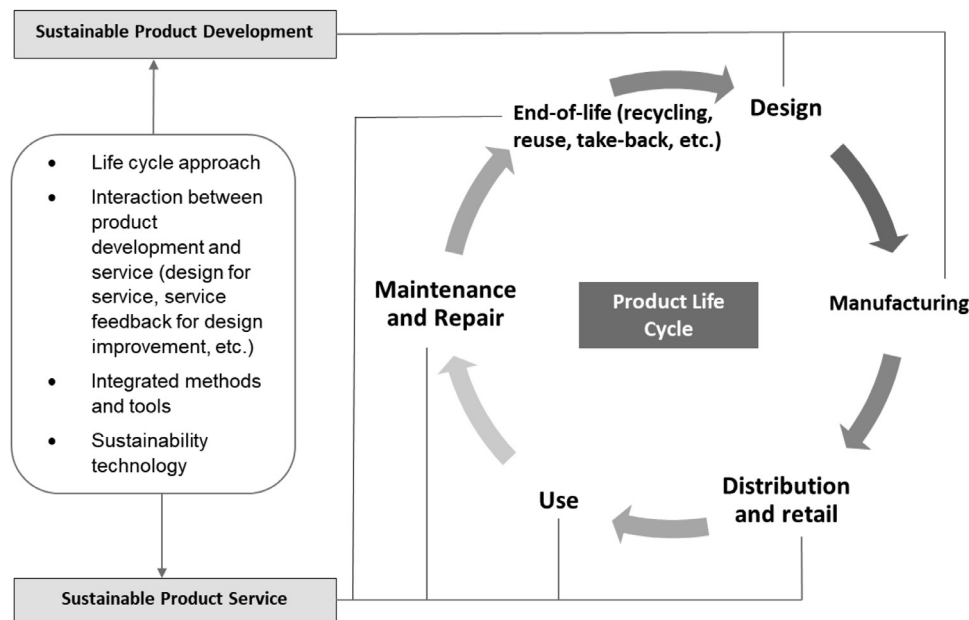

Fig. 1. Sustainable product development and service approach.

ported by sustainable product development and the PSS methodology (Goedkoop et al., 1999), it is significantly advanced than the existing LCM frameworks and PSS applications. The existing frameworks and concepts exhibit certain shortcomings during the implementation of sustainable innovation. For instance, as a business management concept, the LCM focuses on implementing the supply chain information and activities. However, it lacks specific methods in terms of sustainable product development (Remmen et al., 2007). Furthermore, the PSS adds a service component to a physical product in business models (Aurich et al., 2009), such as an after-sale service of the existing product, which merely ensures incremental innovation in products and not a complete transformation in the procedure of system development (Maussang et al., 2009). Therefore, to achieve systematic sustainable innovation, both product development and service must be considered simultaneously.

Thus, the key features of the proposed SPDS approach can be summarized as follows.

- As a life cycle approach developed based on the existing frameworks and approaches, the SPDS is more advanced than the existing LCM and PSS applications.
- It considers all stages of the product life cycle, from product design, manufacture, distribution, retail, use, maintenance, and repair, to EoL.
- The TBL of sustainability is addressed in both products and services.
- The interaction between product development and service phases enhances the sustainability performance.

3.2. Interaction between the product development and product service phases

The connection between the product development and service phases is achieved by DfS and SfD, enabling the two phases to interact and support each other.

The DfS addresses the service factors at the design stage to ensure that the product achieves sustainable functions at relevant stages within the product service phase. For instance, the modular design facilitating the repair, recycle, and reuse of products when they reach the EoL is a DfS method. This method is derived consid-

ering that most sustainable impacts of the products are determined at the design stage, which forms the LCM perspective. Moreover, improving sustainability in the design stage is cost-effective as it can be conveniently controlled (Agudelo et al. 2017).

Conversely, the SfD handles the issues encountered in the product service phase that are associated with the product performance and functions to provide useful feedback to improve the product. As illustrated in Fig. 2, the feedback is used to refine the product design specifications (PDS), which govern the design and manufacture stages to ensure improved product performance, functions, and sustainability.

The interaction between product development and service phases occurs at different stages in the SPDS. For instance, the ability of service is considered as a criterion in the evaluation of potential design concepts; in the detailed design stage, the product features are addressed individually to operate the product service successfully. Section 4.1.1 describes the application of this technique in the lighting product. Additionally, a conceptual construction method is proposed based on the SfD to conceptualise the product and service opportunities towards TBL sustainability at the design stage. Herein, the sustainability performance, including the environmental-LCA (E-LCA) and social-LCA (S-LCA) of the products are assessed to provide feedback on sustainability issues. This aids in identifying the opportunities for a specific enterprise to improve the sustainability performance in the new product and service. The recommendations obtained based on the assessment results can be applied to the construction of sustainable PDS. The method includes three steps, namely data collection, sustainability assessment, and derivation of recommendations and implications for product and service design. This method is the first step in operating the SPDS that reflects the interaction between service and product development phases.

3.3. Implementation of the SPDS approach

Fig. 3 illustrates the SPDS implementation procedure. Initially, sustainable goals are set for the product and/or service by the practitioner of a project. Subsequently, the sustainability assessment is conducted for an existing product in the market (product-in-service). This aids in detecting the sustainable issues from both

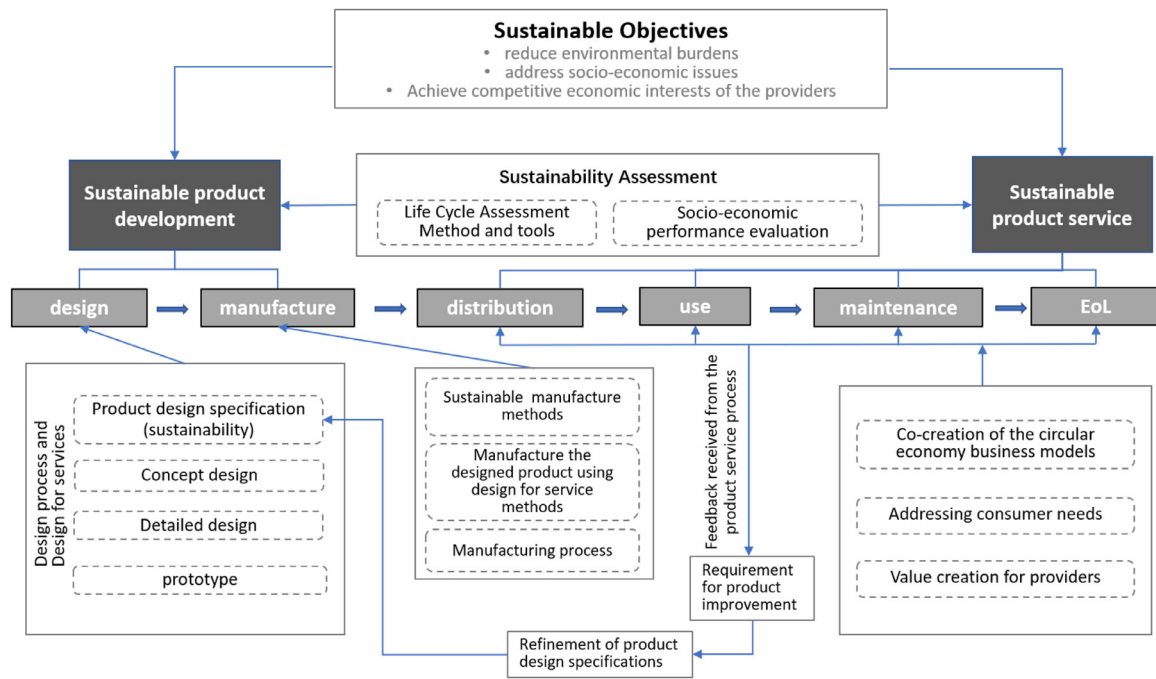

Fig. 2. Approach for sustainable product development and service.

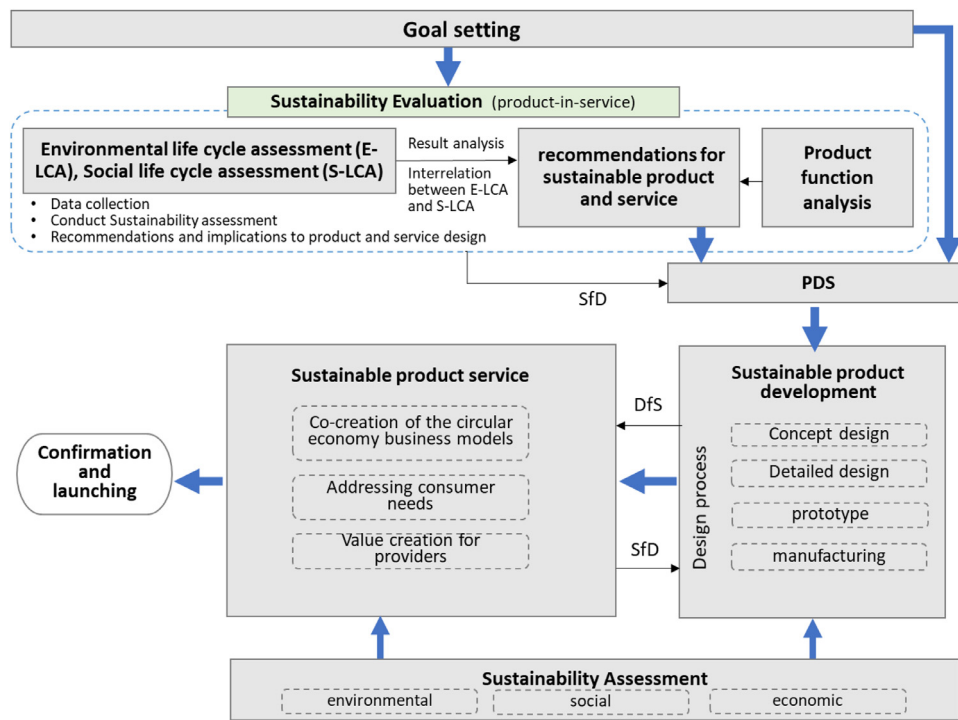

Fig. 3. Flowchart implementing the SPDS procedure.

environmental and social perspectives, which can be used to derive recommendations and implications for the sustainable product and service conceptualisation. LCA methods, including E-LCA and S-LCA, are utilised in this stage. The results obtained from the assessments are analysed and the interlink between the E-LCA and S-LCA results is identified to provide the evidence-based objectives and opportunities for a specific case. The overlapped E-LCA and S-LCA results indicate the key opportunities to improve the overall sustainability. Thus, they can be directly applied to the sustainable product and service conceptualisation. Conversely, individual

S-LCA findings are addressed in the service conceptualisation stage (Section 4.1.1).

The obtained recommendations are integrated with the PDS, and the product design process involving the conceptual design, detailed design, and prototyping is executed. The product design process then undergoes the design iteration process supported by DfS and SfD methods. Subsequently, the sustainable features of the product are derived, followed by the manufacturing process, wherein relevant sustainable manufacture methods are applied.

To develop the product and service interactively, the new product addresses its potential service activities. For instance, based on the take-back service (e.g., take back the EoL product from a customer for reproduction) and design for disassembly, the new product under development optimises the EoL options, such as modular design, which facilitates easy disassembly for repair, recycling, and reuse. Additionally, it aids in choosing the recyclable material for the convenient operation of potential take-back services. Similarly, the service provides feedback to optimise the product characteristics to realise the service in the design stage. As the development of sustainable product and service requires interdisciplinary knowledge, co-creation is conducted based on the knowledge of LCT and LCM. Herein, designers, researchers, and value chain actors are involved in the co-creation to obtain circular economy business models. The goal is to construct a service that can fulfil consumer needs and create value for providers with reduced environmental and social impacts.

The TBL is addressed throughout the development process. The environmental and social aspects are addressed initially via the sustainability assessment. Herein, environmental impacts regarding resources, human health, and ecosystem are assessed, and five types of stakeholders, including workers, society, value chain actors, consumers, and local communities are considered, to comply with the UNEP guidelines (UNEP/SETAC, 2009). Subsequently, the recommendations based on the environmental and social aspects are integrated to obtain the development goals in the PDS of product and service conceptualisation, which ensures that the identified issues are addressed in the innovation. Furthermore, during concept selection and detailed design, the sustainable features are strengthened as the selection process is based on comparative criteria and weighting methods. The criteria include weight, number of materials, ease of manufacturing, flexibility of adjustment, ease of maintenance, life cycle impact, recyclability, cost, serviceability, and technical parameters. The weighting factors range from 1 to 3; the importance of the criteria is considered high when a higher value is assigned to it.

The economic aspect is addressed considering the contribution of the product to the economic development based on the assessment of the stakeholder 'society'. Additionally, a trade-off occurs between the socio-economic and environmental issues when the implications are derived. Moreover, cost-effectiveness is one of the comparative criteria with the highest weighting factors, and the profit competitiveness is addressed in the product service phase, considering factors such as added value analysis and payment plan (Section 4.1.2). Finally, the sustainability assessment is applied to reveal the sustainable performance of the proposed product and service.

4. Results and discussion

4.1. Application of the SPDS approach to an industrial LED lighting product

4.1.1. Sustainable product development

To test the effectiveness of the proposed method, the SPDS approach is applied to an industrial LED lighting system to achieve holistic sustainability.

Industrial lighting products are widely used in warehouses, factories, manufacturing areas, barns, and other environments with an installation height of 4 to 12 m (Fig. 4). This type of LED lighting products exhibits high power (>100 W) and efficiency (>120 lm/W), which saves large amounts of energy in industrial applications.

Initially, we evaluated the life cycle sustainability performance and investigated the existing industrial LED low bay luminaire (Arcus-Compact) depicted in Fig. 5. The life cycle sustainability per-

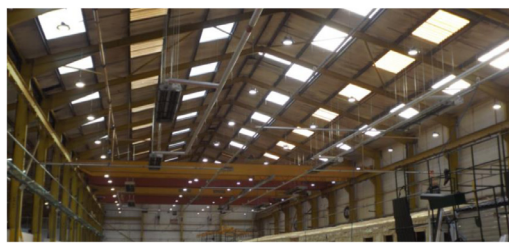

Fig. 4. Industrial LED lighting application scenario.



Fig. 5. Low bay luminaire Arcus-Compact.

formance was evaluated using both E-LCA and S-LCA methods. The assessment included three steps, namely data collection, LCA, and derivation of recommendations. The assessment aimed to derive the sustainable opportunities and implications, identify the interrelationships between the E-LCA and S-LCA results, and derive strategic recommendations to address the TBL sustainability issues in the early product and service development stage.

The E-LCA and S-LCA results indicate that the key life cycle stages and processes of both environmental and social performances overlap. The production stage, LED driver and LED panel, and the production of electricity are identified as the key life cycle stage, components, and process, respectively. The overlapped results are crucial in improving the overall sustainability performance. Therefore, we analysed the interrelation between both results, and the overlapped E-LCA and S-LCA results were directly applied to the sustainable product and service recommendations. Detailed assessments and analyses have been previously reported (Wang et al., 2021).

We derived the sustainable PDS for the new industrial LED lighting product by incorporating the recommendations. Several key characteristics were emphasised in the PDS to develop a sustainable LED lighting product with superior functions. The product service was considered to support the superior functions and operation of the potential PSS. Based on the analysis of the assessment results, establishing a leasing service and a take-back scheme was recommended to the company.

The key sustainable PDS include the following:

- The circuit board must be designed to eliminate or reduce the precious metal inputs within the components by replacing them with other materials. A more compact and efficient driver design is suggested.
- Improved energy efficiency implies that the lighting product provides more brightness by consuming the same amount of electricity as that of the existing product. This can reduce energy consumption-related impact in a specific area and the overall energy cost. This can be achieved by improving the power control system and design using a highly efficient lamp shade.
- A prolonged lifetime is proven to exhibit a lower environmental impact. Implementing a modular design enables the replacement of electronic components within the housing units, which can prolong the lifetime.
- Reduce housing material and refine the product dimensions.

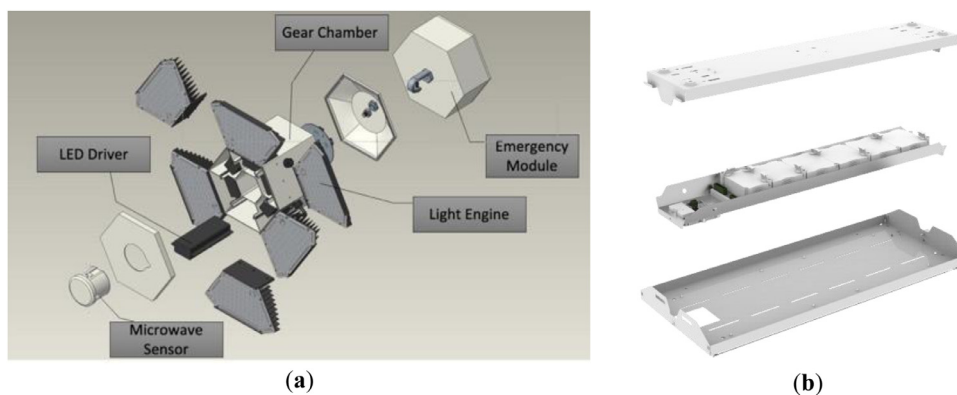

Fig. 6. Conceptual designs. (a) Design concept 1 and (b) design concept 2.

Table 1
Key features and implementation of a sustainable design.

Sustainable design features	Life cycle stages benefitted	Implementation of sustainable PDS
Modular design	Production, use and maintenance (installation), end-of-life treatment	✓
Innovative design of the LED driver	Use and maintenance	✓
High energy-efficient design	Use and maintenance	✓
Compact design	Production and distribution (transportation)	✓
Design for a prolonged lifetime and high reliability	Use and maintenance	✓

- Use recycled packaging material with 80% post-consumer cardboard and 50% recycled plastic materials.
- Design for convenient assembly and disassembly of all components.
- The chlorine content in the recycled plastic materials must be lower than 50%.

Based on the derived PDS, two design concepts (Fig. 6) were introduced and evaluated. The modular design of the structure and components eased the manufacturing, assembly, disassembly, and installation processes. Furthermore, an emergency back-up energy module was added to the potential service (leasing service) with upgraded functionalities. The criteria for concept selection were generated based on the impact control at each stage of the product life cycle. Additionally, we considered the impact of the potential service, such as the environmental impact of the material, cost, recyclability, ease of manufacturing, installation, disassembly, and transportation. Based on these criteria, we selected design concept 2 (Fig. 6 (b)) for detailed designing, which ensures the implementation of key eco-friendly features and effective operation of the potential service in the early design stage. The detailed concept selection process is not presented to maintain brevity.

Fig. 7 depicts the detailed design of the new product, Arcus-II, with an emergency module and sensor options. The overall modular design and ultra-high energy efficiency in the LED low bay model are highlighted in the figure. The design exhibits high adaptabilities, including the efficiency of 123 lm/W, optional emergency function, microwave sensor version, stand-by dimming, daylight threshold conduit, and trunking (surface mounting). Table 1 lists the key features of the industrial low bay luminaire and the implementation of sustainable PDS.

The features implemented to obtain a sustainable design are explained below.

- Modular design: Modular design is the paramount novelty of the proposed model, which ensures superior adaptability and upgradability for its potential service, such as leasing. The structure of the low bay luminaire comprises three primary parts, namely a fixing backplate, gear tray, and lighting unit. The parts can be joined using one or two screws. The con-

trol module, including the driver, sensor, and emergency module is plugged individually on the motherboard inside the gear tray. As illustrated in Fig. 7, the modular design of the housing and control module eases the production, assembly, disassembly, installation, maintenance, and EoL treatment processes owing to the DfS approach. In terms of power, multiple options are available (100 W/150 W/200 W) with specification preferences, such as with a sensor or emergency function. Irrespective of the specification preference, the structure of the luminaire remains constant. As the control module and LED optical panel are the most fragile parts of an LED lighting product, the modular design enables the replacement of the faulty modules without affecting other functional modules. Consequently, the maintenance time and cost are reduced.

- Innovative design of the LED driver: The novel distinctive design aims to prolong the service time of the driver. The individual driver of the existing model (Arcus-Compact) provides the power for the entire lighting product. Consequently, the breakdown of the luminaire is highly possible owing to the overheating of the driver during usage. To overcome this drawback, the new driver was designed to be more compact and reliable. The control system comprises more than one driver depending on the power of the luminaire to ensure that the other drivers are not affected despite the incorrect operation of one driver. Thus, a complete failure of the lighting device can be prevented. In addition, a redundant design is applied to reduce the operational risk of the driver, which can prolong the driver lifetime. Furthermore, the stand-by dimming achieved by the sensor version protects the driver from risks.
- High energy-efficient design: To improve light efficiency, the new model utilises two separate lenses and LED panels. The polarized lenses can provide different options of beam angle with appropriate LED optical arrangement, thus reducing the cost of the LED with improved efficiency. Additionally, the new model exhibits a 7% efficiency improvement, from 115 lm/W to 123 lm/W, owing to the optimised design of the panel and shade.
- Compact design: The new compact design reduces the housing dimensions and the usage of housing materials; recyclable steel sheets are used as housing materials. Additionally, the manufac-

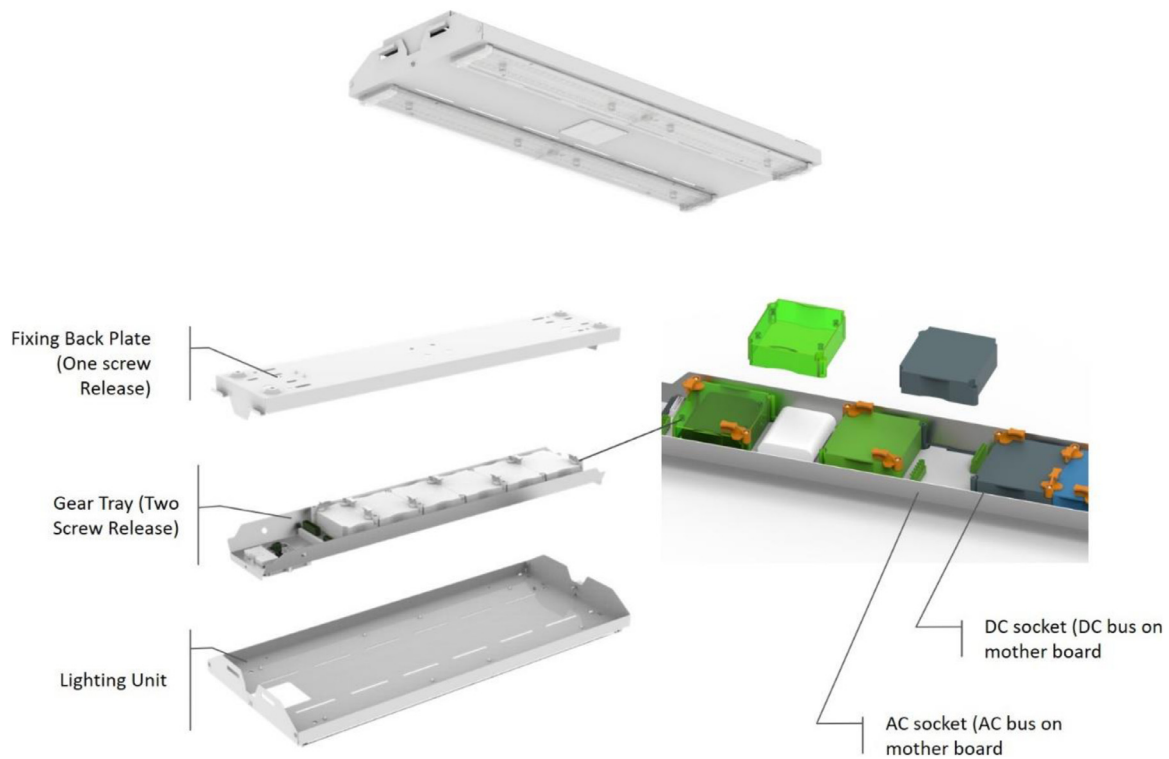

Fig. 7. Sustainable design of Arcus-II.

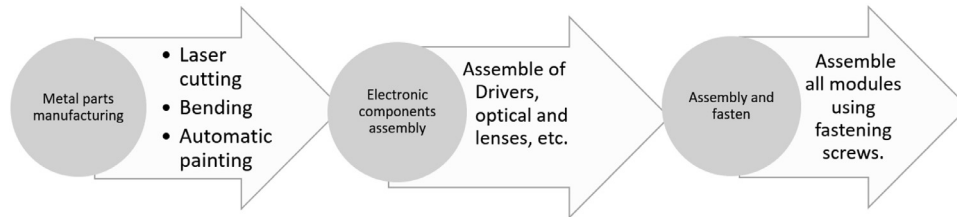

Fig. 8. Manufacture procedure of Arcus-II.

turing processes are simplified owing to the compact and modular design.

- Design for a prolonged lifetime and high reliability: Typically, consumers prefer easily maintained and reliable lighting equipment. Based on this feedback, the new model provides an optional emergency function that can detect potential driver deficiency and dim the light automatically to prevent the breakdown of the luminaire. Consequently, the reliability of the product increases. Furthermore, the modular design eases the maintenance of the luminaire without changing the functional parts, including housing, and enhances the upgradability. This ensures a prolonged lifetime of the proposed service.

The manufacturing procedure of Arcus-II is briefly illustrated in Fig. 8. The housing components are composed of steel sheets that are manufactured by laser cutting and bending; the sheets are coated using an automatic spray machine. The electrical devices from the manufacturing line are assembled within the housing to obtain the final product. The designed modular units are mounted on the product, simplifying and expediting the assembly process significantly. Therefore, the assembly cost is reduced by approximately 30%. Furthermore, the product quality assurance procedure involves quality checking in the production line, early failure pre-

vention conducted at the test station, and maintenance experiment implemented in the lab.

4.1.2. Sustainable service

4.1.2.1. Sustainable product-service system. Kosnic Lighting Ltd. (UK) is an independent British company that incorporates innovative designs and manufacturing processes to provide robust lamps, luminaires, and bespoke lighting solutions. The company is known for adapting efficient practices that deliver quality, cost-effective, and environmentally responsible lighting solutions for residential, commercial, and public sectors. As research and innovation are essential in this focal company, it recently participated in the EU H2020 research project CIRC4Life as an industrial partner. The primary task was to develop a sustainable LED lighting product with integrated sustainable product design methods that can maximise the energy-efficient and cost-saving features of LED technology. Additionally, its application in a circular economy-based business context was demonstrated to achieve the TBL of sustainability in their product and service.

The objective of the focal company was to develop a sustainable product that can reduce material and energy consumption environmentally, benefit society and stakeholders socially, and generate value and profit economically, thus achieving the TBL of sus-

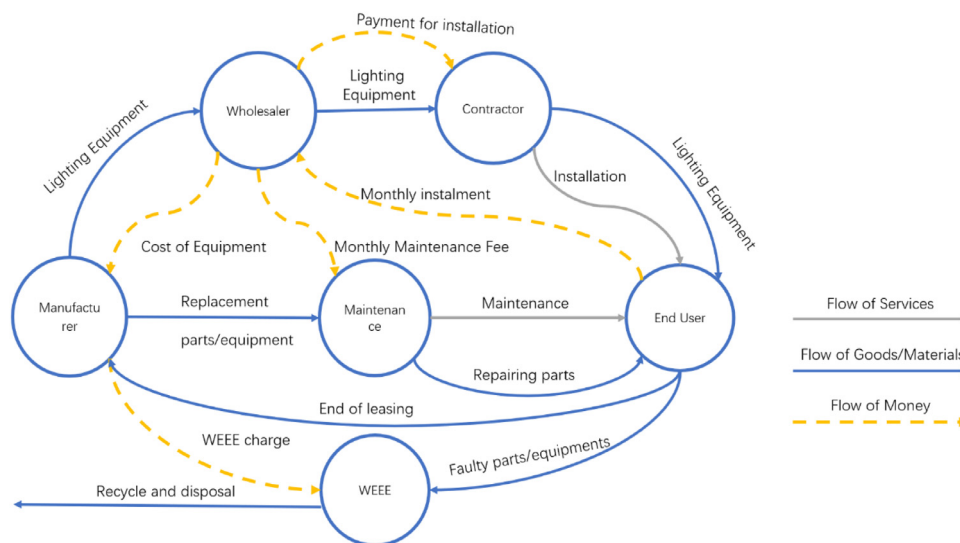

Fig. 9. Eco-system of the leasing service.

tainability. Hence, the proposed SPDS approach was implemented to develop the new lighting product based on the company's requirements.

Considering the recommendations from a social performance study (Wang et al., 2021), we explored the product–service bundle to obtain a sustainable product and a possible service implementation. Additionally, consumer needs and potential added values were analysed to construct a service that can generate value for the providers and achieve consumer satisfaction with reduced environmental and social impacts. We recognised the need for additional value-added services that can contribute to the product longevity, energy reduction and profit generation. Therefore, we focused on generating value-adding innovative services throughout the LED lighting's lifetime for consumer satisfaction.

4.1.2.2. Leasing services. The proposed leasing service is a use-oriented PSS (Williams, 2007), wherein customer satisfaction implies benefitting from the function of products or services rather than the ownership (Chou et al., 2015). The proposed service provides the most effective illumination plan to the end-user in a contracted time.

Fig. 9 illustrates the eco-system of the LED lighting product leasing service. Herein, the wholesale brokers and managers lease the service to the end-user, the manufacturer supplies the lighting equipment and parts, the contractor is responsible for the installation, and the maintenance company supervises the equipment. Additionally, the manufacturer uses waste electrical and electronic equipment (WEEE) service to recycle and dispose faulty and EoL products.

The PSS includes the illumination plan, providing the lighting equipment, installation, maintenance, and EoL take-back services. The company uses technical expertise to develop a bespoke plan, producing the required lighting equipment that best suits the application and conforms to all necessary standards and regulations. The wholesaler leads the commercial activities in identifying local business opportunities. After finalising the leasing contract, the electrical wholesaler works with other partners to deliver the equipment and services accordingly.

The wholesaler collects the payments in instalments to pay the other business partners. Figs. 10 and 11 illustrate the stepped and flat payment plans, respectively, which are offered to the leasing customers. The figures depict a complete leasing cost of £240 for

conventional industrial lighting. The leasing contract term is of five years with payment considered for 20 quarters.

For instance, a leasing cost of £240 comprises £120 of the product cost, £20 for parts, £40 as installation fee, and £60 as maintenance charge. Herein, we considered the financial cost of leasing, such as interest and profit for each party of the lessor side. In the case of stepped payment plan, the installation fee of £40 is paid at the beginning of the leasing contract, whereas the remaining cost spans over five years with quarterly payments of £10. Conversely, a fixed quarterly payment of £12 is applied for the entire leasing term in the flat payment plan. In both payment schemes, the customer can pay the instalments quarterly rather than a substantial amount as a one-time payment. Although the stepped payment plan requires a small proportion of installation cost at the beginning, it is a flexible financial plan that provides lighting maintenance for the customers. Moreover, energy savings owing to the high energy-efficient design of the equipment compensates for the additional financial costs of the leasing services. Consequently, expensive lighting projects turn affordable under the leasing services, thus generating potential business opportunities and additional revenues for the company.

In this study, the owner of the lighting equipment is Kosnic. Therefore, Kosnic reclaims the lighting equipment at the end of the leasing contract. Owing to the novel modular design, numerous components can be recycled, reused, and re-engineered to extract the maximum residual value of the used lighting equipment. Moreover, the disposal of fewer parts of the lighting equipment reduces the WEEE charges.

Furthermore, a multi-party leasing contract is proposed to ensure that every stakeholder in the PSS eco-system (Fig. 9) fulfils its role. Fig. 12 illustrates the processes and available options for renewing or terminating the leasing contract. Herein, the customers can choose to update to the latest lighting technology with the continual improvement of LED efficiency during the term. While this option involves an incentive discount, the customers are penalised with additional charges to cover the remaining financial cost if the leasing contract is terminated before the end of the term. At the end of the leasing agreement, a new leasing contract with the latest and most efficient products is recommended to the customer with an option to continue using the leasing equipment by paying a flat maintenance charge.

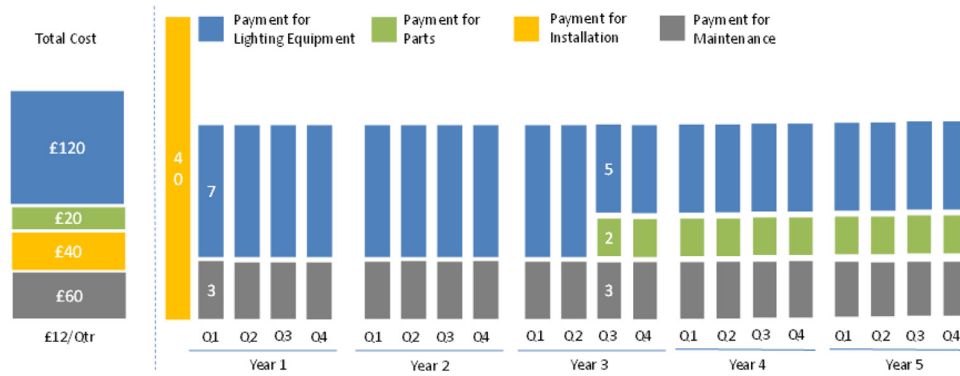

Fig. 10. Stepped payment plan.

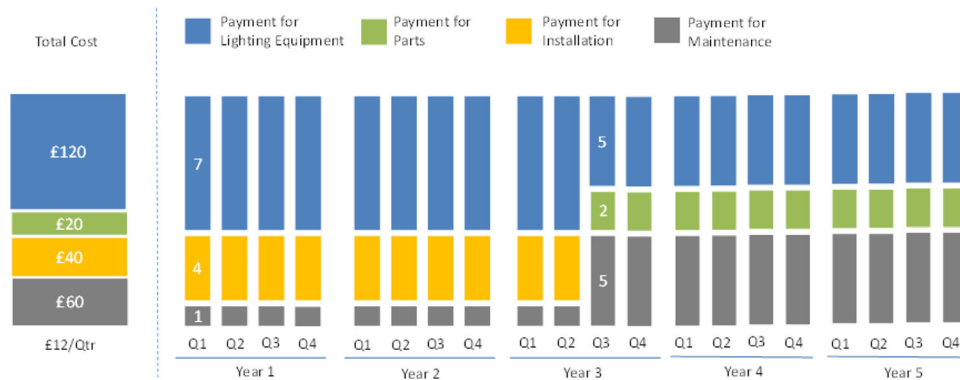

Fig. 11. Flat payment plan.

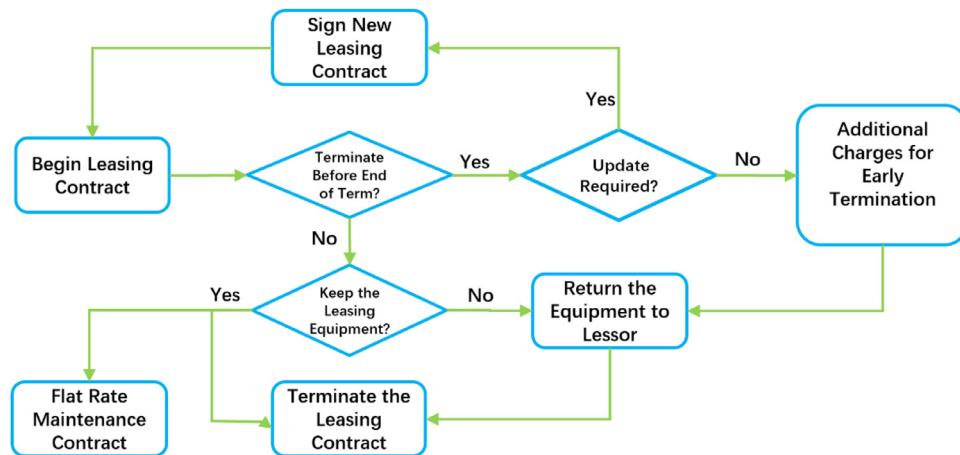

Fig. 12. Flowchart of the leasing contract.

Thus, the benefits of the leasing service can be summarized as follows.

- Required capital for the business is reduced, particularly in the case of small- and medium-sized enterprises with limited cash flow.
- Flexible financial plan provided to the end-user increases business opportunities and revenue.
- Leasing services are affordable as their financial cost can be compensated by the energy savings generated owing to the latest LED technology.
- Free maintenance, scheduled services, and emergency repair.
- Increased recycling rate of the lighting equipment.
- Reduced waste treatment and disposal costs.

- Reduced energy consumption owing to the high efficiency of the lighting product.
- Flexible contracts with options to upgrade, transfer ownership, terminate, and extend.



4.2. Sustainability evaluation

4.2.1. LCA

4.2.1.1. Goal. The goal is to compare the overall environmental performance of the existing LED lighting product (Arcus-Compact) with that of the newly designed Arcus-II to identify the effects of sustainable design on the environmental profile.

4.2.1.2. Functional unit. The functional unit considered one unit of both luminaires' lifetimes (40000 h) to determine the environmen-

Table 2
Technical specifications of Arcus-Compact and Arcus-II based on the comparative LCA.

Product Name	Arcus-II	Arcus-Compact
		
Power	100 W	100 W
Voltage	200–240 V 50–60 Hz	200–240 V 50–60 Hz
Beam angle	polarized	120
CCT (K)	6500	6500
Luminous flux (Lm)	12000 lm	11500 lm
Detentions (Mm)	681 × 87 × 74	600 × 327 × 84
CRI	>83	>80
Lifetime (H)	40000	40000
Power factor	0.96	0.95
Ambient temperature (°C)	–20 to 40	–20 to 40

tal impacts. The LED lighting products used in this study are manufactured in China (Hangzhou) and shipped to the UK for wholesaling. Both Arcus-Compact and Arcus-II, distributed by Kosnic Lighting Ltd. (UK), can be applied in industrial areas, such as manufacturing workshops, warehouses, leisure facilities, and retail environments. Table 2 lists the technical specifications of the products.

4.2.1.3. System boundary. All life cycle stages, including the raw material extraction, production of basic materials, production of the components, LED lighting assembly, packaging, distribution (transportation), and EoL treatment were considered within the system boundary. The production and assembly of components and sub-systems were considered in the manufacturing stage, which involves the raw material acquisition, product assembly, energy consumption, generation of waste or emissions, and disposal. Additionally, the packaging and transportation activities during production were examined within the boundary. Furthermore, energy consumed during the usage of the product were considered; the LED lighting product was assumed to serve until the end of its useful life (40000 h).

4.2.1.4. Inventory data. Table 3 lists the inventory data of the two products. The data of material use, manufacturing processes, and energy consumption were acquired from the manufacturer. The background data, such as the raw material extraction and production of the basic materials were derived from the Ecoinvent 3.5 database (Ecoinvent, 2018). Both electricity usage and EoL treatment were considered in terms of the scenario in the UK, based on the WEEE directive. The shipping distance from Hangzhou to London (UK) was obtained using Google Maps. As most of the inventory data (Table 3) are provided by the manufacturer, the data quality is considered satisfactory with low uncertainty. During the usage of the product, the required electricity was calculated by multiplying the products' power with useful time. Despite the uncertainty of whether the lighting product can be used until the end of its useful time, the results of the comparative LCA remained unaffected as both products utilised the same amount of power (100 W). Furthermore, although Arcus-II was recycled considering an ideal scenario, which can constitute another uncertainty, the results were not highly affected as the impact of recycling is minimum.

4.2.1.5. Life cycle impact assessment (LCIA). The assessment models were developed using openLCA in line with the Ecoinvent 3.5 database (Ecoinvent, 2018). The comparative LCA was performed

based on the ReCiPe hierarchist perspective (Goedkoop et al., 2009) as it is the most recent and harmonized LCIA approach (Huijbregts et al., 2016). Moreover, it can combine LCA results into a single score via weighting, which allows convenient comparison of the environmental impacts of different products or scenarios (Kalbar et al., 2017). Furthermore, endpoint assessments were conducted considering the three endpoint impact categories, namely ecosystems, resources, and human health. The normalisation and weighting methods (World ReCiPe H/A (person/year)) were applied to obtain the individual scores of the three categories, which were aggregated to determine the overall environmental impact score of each assessed unit. To support further researches regarding the LCA of LED lighting products, the midpoint results (ReCiPe midpoint H) are provided in the supplementary material.

4.2.2. LCA results and discussion

Fig. 13 depicts the single score results of the three impact categories of both products. The environmental impact assessment results indicate that the environmental performance of the newly designed product (Arcus-II) has improved by 46% in comparison with that of the existing product (Arcus-Compact). We observed a reduction from 169 Pt to 91 Pt based on the aggregated endpoint single scores. For instance, $55.46 + 34 + 1.87 = 91.33$ (Fig. 13). The environmental impacts of the three categories in the case of Arcus-II are 55.46, 34, and 1.87 for resources, human health, and ecosystems categories, which are improved by 43, 50, and 35%, respectively in comparison with those of Arcus-Compact. Among the three impact categories, resources are the most affected (key impact category), which contributes to 60 and 57% of the total impacts of Arcus-II and Arcus-compact, respectively. This is followed by human health; ecosystems are the least affected impact category.

The impact category resource is dominated by the production/assembly stage and the use stage in the case of both the products as these stages require high energy and material. In Arcus-Compact, the contribution of the production/assembly stage (approximately 58%) to the total impact is higher than that of the use stage (42%), which can be primarily attributed to the production of electronic devices. By contrast, the primary contributor (75%) in Arcus-II is the electricity production during usage, whereas the production/assembly stage contributes approximately 25% to the total impact. A similar pattern was observed in other endpoint impact categories. The usage and production method of electricity is identical in both products. However, Arcus-Compact

Table 3
Inventory data of Arcus-Compact and Arcus-II.

Product	Assembly component	Material	Amount	Unit
Arcus-II	Electronic control unit	LED optics	0.25	kg
		Aluminium	0.035	kg
		Plastic (junction board)	0.013	kg
		Steel (base module)	0.545	kg
		Wire board	0.42	kg
		Plastic (LED driver)	0.033	kg
	Fastening member	Nickel-coated iron	0.0734	kg
		Steel sheet (housing)	1.525	kg
	Housing	Plastic sheets (plastic members)	0.2212	kg
		Plastic (lens)	0.4	kg
		Paper printed board box	0.96	kg
	Packaging	Plastic film	0.0003	kg
		Paper	0.0004	kg
		Plastic foam	0.054	kg
	Electricity		4000	kW*h
	Shipping		52896	kg*km
	Recycle	Steel	2.07	kg
		Plastic	0.6212	kg
	Electric devices		1.1	kg
	General waste		0.099	kg
	Arcus-Compact	Housing	Plastic	0.29
Steel			2.199	kg
LED driver		Aluminum	1.1	kg
		Plastic	0.172	kg
LED lighting board		Printed circuit board	0.688	kg
		LED	0.32	kg
Junction box		Aluminum	0.012	m ²
		Plastic	0.02	kg
Press button		Plastic	0.007	kg
Fastening members		Steel	0.07838	kg
		Plastic	0.0016	kg
Packaging		Printed board box	1.17	kg
		Plastic film	0.0003	kg
		Paper	0.0004	kg
		Plastic foam	0.066	kg
Electricity			4000	kW*h
Shipping			56451.96	kg*km
Solid waste			5.3207	kg
Waste paperboard			1.8537	kg

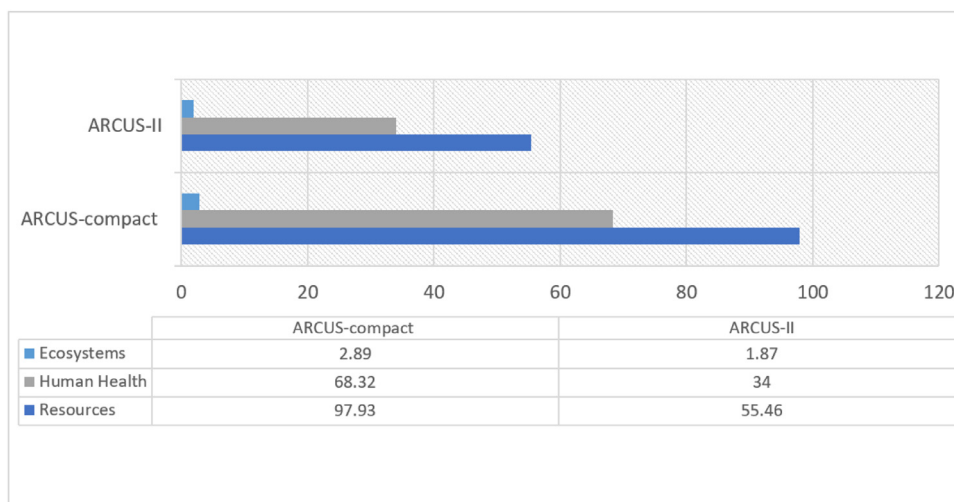

Fig. 13. Endpoint single score results of Arcus-Compact and Arcus-II.

and Arcus-II accounted for 42 and 75% of the total impact, respectively. This implies that the impact of Arcus-II reduces significantly from the production stage (58% to 25%), thereby demonstrating that the LED lighting product developed using the proposed SPDS approach exhibits an outstanding overall environmental improvement owing to the impact reduction during the production stage.

We selected the standard version of Arcus-II for the comparison LCA. In a real-time scenario, the newly designed product can offer better environmental performance for a longer time. For instance, the new product can be fixed by replacing a few components when a breakdown occurs, whereas, in the case of the existing product, the entire luminaire must be replaced. Thus, the materials required for manufacturing the new product are reduced over time,

Table 4
Environmental and economic benefits of the new product and service system.

	Existing illumination plan	Illumination plan using the proposed sustainable product and service	Savings per year
Cost of electricity per kW*H	£0.15	£0.15	
Hours per year	3000	3000	
Area	Warehouse 1	Warehouse 1	
Quantity	50	50	
Replacement LED fitting type	4 × 54 W Fluorescent T5 Low Bays	150 W Arcus-II - KLBA150L1	
Replacement LED fitting (Wattage)	236	150	4300
LED fitting life (Hours)	12,000	40,000	
LED electricity cost per year (£)	£5310.00	£3375.00	£1,935.00
LED fitting costs per year	£402.50	£277.50	
LED fitting + Electricity costs per year	£5712.50	£3652.50	£2,060.00
LED kilowatts per year	35,400	22,500	12,900
Environmental impact in CO ₂	18,833	11,970	6,863
	Year 1	Year 2	Year 3
Existing costs (lamps and electricity)	£5,712.50	£5,712.50	£5,712.50
LED costs (purchase in year 1 + electricity costs)	£6,825.00	£3,375.00	£3,375.00
Payback period (months)	18		
Savings per year	£2,337.50		
Savings over life of the LED	£31,166.67		

which reduces the environmental impact. However, certain qualitative eco-features, such as easy transportation, convenient disassembly and repair, reduced packaging material and space, cannot be assessed using an LCA process as they cannot be converted into numerical values. Consequently, they were not considered in the assessment owing to the quantitative nature of the LCA methodology. Nevertheless, these eco-features enhanced the overall sustainability significantly.

4.2.3. TBL of sustainability

Based on the recommendations derived from the E-LCA and S-LCA (Section 4.1), we developed the new product and service to address the risks identified. The new sustainable product and service achieved the TBL of sustainability with environmental and socio-economic benefits. We applied the new sustainable LED lighting products (Arcus-II) and their services at a site where the existing illumination plan was to be replaced. Table 4 lists the environmental and economic benefits of the implemented system.

We observed that replacing the existing lighting products with the proposed lighting leasing service exhibits multiple benefits with the same illumination. For instance, Arcus-II can save the warehouse 12900 KW of energy consumption, which accounts for £1935 in electricity bill and 6863 CO₂ emissions. Particularly, the consumers can save up to £2337.5 per year and £31166.67 over the life of the LED when adopting a 3-year payment plan.

In addition, implementing the proposed product–service system benefits supply chain actors, workers, and consumers. The existing illumination plan is a product-sale business model, wherein the profit and margin are added at every stage of the supply chain without considering the product's entire life cycle. Although this system may initially benefit the suppliers owing to the selling of products, not considering the prolongation of the product lifetime and reuse or repair of the product increases the number of waste disposals, resulting in inefficient products. Conversely, the modular design of the sustainable product simplifies the assembly process significantly, reduces the assembly cost by approximately 30%, and relieves the workers of their workload. Moreover, the cradle-to-cradle life cycle development approach enhances the socio-economic benefits, and sustainable innovation proves useful to the value chain actors. Owing to the new roles required by the PSS, new jobs are generated and all stakeholders benefit from a healthy recurring profit stream. The company can enhance the

reusability of materials, tools, and facilities, minimising waste disposal. Moreover, it encourages its sub-contract manufacturers to dedicate sustainable product and service innovations to provide the best possible solutions using reliable products. The collaboration of all partners under this leasing model aims to provide an ideal user experience for the clients. Additionally, bespoke illumination plans ensure closer interactions between the manufacturer and end-user.

The company gained prominent recognition in the lighting industry sector in terms of social responsibility and product quality. Kosnic joined the elite group of Accredited Suppliers to The Carbon Trust, the market-leading scheme for high-quality energy-efficient equipment and renewable technology suppliers worldwide. Additionally, the welfare of the employees in the company was valued as satisfactory.

Finally, the sustainable product and service facilitated responsible and sustainable consumption by the end-users, which is essential to develop a relationship between sustainable product–service system and the implementation of sustainability.

4.3. Implications and limitations

The SPDS approach aims to support systemic innovation of sustainable product development and services. Unlike the existing approaches, the SPDS approach addresses the TBL of sustainability through the simultaneous development of product and service. As the approach considers the entire product life cycle rather than focusing on the design of the physical product, radical systematic innovations can be achieved towards sustainability. The product and service conceptualisation methods can identify and set sustainable objectives to construct sustainable PDS. In addition, the proposed DfS and SfD methods demonstrate the implementation of interconnection between sustainable product and service through the development process. Additionally, the study presents the integration of the sustainability assessment into the SPDS approach. The sustainable LED lighting product and PSS developed by utilising this approach verify the design for sustainability for future studies.

However, the social sustainability in the product and service must be improved by addressing the social issues identified in the sustainability assessment. Owing to the limitations in evaluating the sustainability performance of the leasing service, no agreed assessment method can be currently applied. Therefore, we intend

to conduct the sustainability evaluation of the service and the integration of evaluation results in the future for improved decision making and sustainable consumption.

5. Conclusions

To achieve the TBL of sustainability, we proposed an SPDS approach that considers a product's entire life cycle. The effectiveness of the proposed approach is demonstrated using an industrial LED lighting product. The sustainable LED lighting product and service developed by utilising this approach exhibited prominent environmental, social, and economic benefits.

The environmental assessment results indicate that the sustainable LED lighting product developed using the SPDS approach exhibits a 46% lower environmental impact. Additionally, the sustainable product and service bundle reduces the illumination cost for the end-users significantly while providing environment-friendly products and hassle-free services, along with several socio-economic benefits. The developed product and service promote workers' welfare, reduce the expenditure of manufacturers, and generate a healthy recurring profit stream for all stakeholders. Thus, the SPDS approach can effectively develop products and services that advance the TBL of sustainability. This approach can be applied to other industrial sectors as well.

Declaration of Competing Interest

The authors declare that they have no known competing financial interests or personal relationships that could have appeared to influence the work reported in this paper.

Acknowledgements

This research was supported by the European Commission H2020 Circular Economy Programme [grant number 776503].

Supplementary materials

Supplementary material associated with this article can be found, in the online version, at doi:10.1016/j.spc.2021.04.003.

References

- Agudelo, L.M., Nadeau, J.P., Pailhes, J., Mejía-Gutiérrez, R., 2017. A taxonomy for product shape analysis to integrate in early environmental impact estimations. *Int. J. Interact. Des. Manuf.* 11 (2), 397–413. doi:10.1007/s12008-016-0337-0.
- Aurich, J.C., Wolf, N., Siener, M., Schweitzer, E., 2009. Configuration of product-service systems. *J. Manuf. Technol. Manag.* 20 (5), 591–605. <http://dx.doi.org/10.1108/17410380910961000>.
- Andriankaja, H., Vallet, F., Le Duigou, J., Eynard, B., 2015. A method to ecodesign structural parts in the transport sector based on product life cycle management. *J. Clean. Prod.* 94, 165–176. doi:10.1016/j.jclepro.2015.02.026.
- Baumann, H., Anne-Marie, T., 2004. *The Hitch Hiker's Guide to LCA: an Orientation in Life Cycle Assessment Methodology and Application*. Studentlitteratur, Lund, Sweden.
- Chou, C.J., Chen, C.W., Conley, C., 2015. An approach to assessing sustainable product-service systems. *J. Clean. Prod.* 86, 277–284. doi:10.1016/j.jclepro.2014.08.059.
- Clark, G., Kosoris, J., Hong, L.N., Crul, M., 2009. Design for sustainability: current trends in sustainable product design and development. *Sustainability* 1 (3), 409–424. doi:10.3390/su1030409.
- Clean Energy Ministerial, Global lighting challenge, n.d. <http://www.cleanenergyministerial.org/campaign-clean-energy-ministerial/global-lighting-challenge> (accessed 20 February 2021).
- Dowie, T., 1994. Green design. *World Class Des. Manuf.* 1 (4), 32–38. doi:10.1108/09642369210063045.
- Elkington, J., 1997. *Cannibals with Forks – the Triple Bottom Line of 21st Century Business*. New Society Publishers, Stoney Creek, CT.
- Ecoinvent 3.5 2018. <https://www.ecoinvent.org/database/older-versions/ecoinvent-35/ecoinvent-35.html> (accessed 06 November 2019).
- EU Science Hub. 2018. 'Sustainable Product Policy', Last Updated 13 December 2018. <https://ec.europa.eu/jrc/en/research-topic/sustainable-production-and-consumption> (accessed 19 February 2021).
- Fava, J.A., Denison, R., Jones, B., Curran, M.A., Vigon, B., Selke, S., Barnum, J., 1991. A technical framework for life-cycle assessment: workshop report. Society of Environmental Toxicology and Chemistry, Washington DC.
- Gbededo, M.A., Liyanage, K., Garza-Reyes, J.A., 2018. Towards a life cycle sustainability analysis: a systematic review of approaches to sustainable manufacturing. *J. Clean. Prod.* 184, 1002–1015. doi:10.1016/j.jclepro.2018.02.310.
- Goedkoop, M., Heijungs, R., Huijbregts, M., De Schryver, A., Struijs, J., Van Zelm, R., 2009. ReCiPe 2008-a life cycle impact assessment method which comprises harmonised category indicators at the midpoint and the endpoint level. 1–44. https://www.leidenuniv.nl/cml/ssp/publications/recipe_characterisation.pdf.
- Goedkoop, M.J., Van Halen, C.J., Te Riele, H.R., Rommens, P.J., 1999. Product service systems, ecological and economic basics report for Dutch ministries of environment (VROM) and economic affairs (EZ). Report for Dutch Ministries of environment (VROM) and economic affairs (EZ). 36(1), 1–122.
- González-García, S., Lozano, R.G., Buyo, P., Pascual, R.C., Gabarrell, X., I Pons, J.R., Moreira, M.T., Feijoo, G., 2012. Eco-innovation of a wooden based modular social playground: application of LCA and DfE methodologies. *J. Clean. Prod.* 27, 21–31. doi:10.1016/j.jclepro.2011.12.028.
- He, B., Li, F., Cao, X., Li, T., 2020. Product sustainable design: a review from the environmental, economic, and social aspects. *J. Comput. Inf. Sci. Eng.* 20 (4). doi:10.1115/1.4045408, 040801.
- Heintz, J., Belaud, J.P., Gerbaud, V., 2014. Chemical enterprise model and decision-making framework for sustainable chemical product design. *Comput. Ind.* 65 (3), 505–520. doi:10.1016/j.compind.2014.01.010.
- Huijbregts, M.A., Steinmann, Z.J., Elshout, P.M., Stam, G., Veronesi, F., Vieira, M.D.M., Hollander, A., Zijp, M., van Zelm, R., 2016. ReCiPe 2016-a harmonized life cycle impact assessment method at midpoint and endpoint level Report I: characterization. RIVM Report 2016-0104. National Institute for Human Health and the Environment, Bilthoven.
- ISO (International Organization for Standardization), 2006. ISO 14044: environmental management—life cycle assessment—requirements and guidelines. <https://www.iso.org/standard/38498.html?browse=tc> (accessed 1 April 2018).
- Kalbar, P.P., Birkved, M., Nygaard, S.E., Hauschild, M., 2017. Weighting and aggregation in life cycle assessment: do present aggregated single scores provide correct decision support? *J. Ind. Ecol.* 21 (6), 1591–1600. doi:10.1111/jiec.12520.
- Kravchenko, M., Pigosso, D.C., McAloone, T.C., 2019. Towards the ex-ante sustainability screening of circular economy initiatives in manufacturing companies: consolidation of leading sustainability-related performance indicators. *J. Clean. Prod.* 241, 118318. doi:10.1016/j.jclepro.2019.118318.
- Lumsakul, P., Sheldrick, L., Rahimifard, S., 2018. The sustainable co-design of products and production systems. *Procedia Manuf.* 21, 854–861. <https://doi.org/https://doi.org/10.1016/j.promfg.2018.02.193>.
- Malek, J., Desai, T.N., 2020. A systematic literature review to map literature focus of sustainable manufacturing. *J. Clean. Prod.* 256, 120345. doi:10.1016/j.jclepro.2020.120345.
- Manzini, E., Vezzoli, C., 2003. A strategic design approach to develop sustainable product service systems: examples taken from the 'environmentally friendly innovation' Italian prize. *J. Clean. Prod.* 11 (8), 851–857. [https://doi.org/https://doi.org/10.1016/S0959-6526\(02\)00153-1](https://doi.org/https://doi.org/10.1016/S0959-6526(02)00153-1).
- Maussang, N., Zwolinski, P., Brissaud, D., 2009. Product-service system design methodology: from the PSS architecture design to the products specifications. *J. Eng. Des.* 20 (4), 349–366. doi:10.1080/09544820903149313.
- Maxwell, D., Van der Vorst, R., 2003. Developing sustainable products and services. *J. Clean. Prod.* 11 (8), 883–895. doi:10.1016/S0959-6526(02)00164-6.
- McAloone, T.C., Bey, N., 2009. Environmental Improvement through Product Development - a Guide. Copenhagen Denmark, Danish EPA P46.
- Mont, O.K., 2002. Clarifying the concept of product-service system. *J. Clean. Prod.* 10 (3), 237–245. [https://doi.org/10.1016/S0959-6526\(01\)00039-7](https://doi.org/10.1016/S0959-6526(01)00039-7).
- Onat, N.C., Kucukvar, M., Halog, A., Cloutier, S., 2017. Systems thinking for life cycle sustainability assessment: a review of recent developments, applications, and future perspectives. *Sustainability* 9 (5), 706. doi:10.3390/su9050706.
- Principi, P., Fioretti, R., 2014. A comparative life cycle assessment of luminaires for general lighting for the office—compact fluorescent (CFL) vs Light Emitting Diode (LED)—a case study. *J. Clean. Prod.* 83, 96–107. doi:10.1016/j.jclepro.2014.07.031.
- Remmen, A., Jensen, A.A., Frydendal, J., 2007. Life cycle management: a business guide to sustainability. UNEP/SETAC publication. <http://www.unep.fr/scp/lcinitiative/publications/>.
- Roy, R., 2000. Sustainable product-service systems. *Futures* 32 (3–4), 289–299. doi:10.1016/S0016-3287(99)00098-1.
- Salari, M., Bhuiyan, N., 2016. A proposed approach to improve current sustainable product development. *J. Ind. Prod. Eng.* 33 (5), 297–307. doi:10.1080/21681015.2016.1172122.
- Sakundarini, N., Taha, Z., Abdul-Rashid, S.H., Ghazila, R.A.R., 2013. Optimal multi-material selection for lightweight design of automotive body assembly incorporating recyclability. *Mater. Des.* 50, 846–857.
- Stahel, W., 2001. Sustainability and services. In: Charter, M.U., Tischner, U. (Eds.), *Sustainable Solutions—Developing Products and Services for the Future*. Greenleaf Publishing, Sheffield P151–162.
- Statista, 2013. Electricity consumption of lighting fixtures in the United Kingdom. <https://www.statista.com/statistics/617777/electricity-consumption-of-lighting-sectors-uk/> (accessed 31 August 2020).
- Stoffels, P., Kaspar, J., Bähre, D., Vielhaber, M., 2018. Integrated product and production engineering approach—a tool-based method for a holistic sustainable design, process and material selection. *Procedia Manuf.* 21, 790–797. <https://doi.org/https://doi.org/10.1016/j.promfg.2018.02.185>.

- Tähkämö, L., Puolakka, M., Halonen, L., Zissis, G., 2012. Comparison of life cycle assessments of LED light sources. *J. Light Vis. Environ.* 36 (2), 44–54. doi:[10.2150/jlve.36.44](https://doi.org/10.2150/jlve.36.44).
- Tukker, A., Tischner, U., 2006. Product-services as a research field: past, present and future. Reflections from a decade of research. *J. Clean. Prod.* 14 (17), 1552–1556. doi:[10.1016/j.jclepro.2006.01.022](https://doi.org/10.1016/j.jclepro.2006.01.022).
- UNEP/SETAC, 2009. Guidelines for social life cycle assessment of products. http://www.unep.fr/shared/publications/pdf/dtix1164xpa-guidelines_slca.pdf. (accessed 03 April 2019).
- Vezzoli, C., Kohtala, C., Srinivasan, A., Xin, L., Fusakul, M., Sateesh, D., Diehl, J.C., 2014. *Product-Service System Design for Sustainability*. Greenleaf Pub., Sheffield, pp. 29–42.
- Wang, S.Y., Su, D., Wu, Y., Zhu, S.F., Kuang, W.T.(Unpublished results), 2021. *Environmental and Social Lifecycle Assessments of an Industrial Lighting Product*. *Environ. Impact. Assess. Rev* Under review.
- Wang, S., Su, D., Wu, Y., Chai, Z.J., 2020. Application of life-cycle assessment to the eco-design of LED lighting products. *Euro-Mediterranean J. Environ. Integr.* 5, 1–10. doi:[10.1007/s41207-020-00180-0](https://doi.org/10.1007/s41207-020-00180-0).
- Williams, A., 2007. Product service systems in the automobile industry: contribution to system innovation? *J. Clean. Prod.* 15 (11–12), 1093–1103. doi:[10.1016/j.jclepro.2006.05.034](https://doi.org/10.1016/j.jclepro.2006.05.034).
- Zarandi, M.H.F., Mansour, S., Hosseinijou, S.A., Avazbeigi, M., 2011. A material selection methodology and expert system for sustainable product design. *Int. J. Adv. Manuf. Technol.* 57 (9–12), 885–903. doi:[10.1007/s00170-011-3362-y](https://doi.org/10.1007/s00170-011-3362-y).
- Zhang, X., Zhang, L., Fung, K.Y., Bakshi, B.R., Ng, K.M., 2020. Sustainable product design: a life-cycle approach. *Chem. Eng. Sci.* 217, 115508. doi:[10.1016/j.ces.2020.115508](https://doi.org/10.1016/j.ces.2020.115508).
- Zhang, Y., Luo, X., Buis, J.J., Sutherland, J.W., 2015. LCA-oriented semantic representation for the product life cycle. *J. Clean. Prod.* 86, 146–162. doi:[10.1016/j.jclepro.2014.08.053](https://doi.org/10.1016/j.jclepro.2014.08.053).