

**Aesthetic Complexity:  
Practice and Perception  
in Art & Design**

Guy Birkin

A thesis submitted in partial fulfilment of the requirements of  
Nottingham Trent University for the degree of Doctor of Philosophy

October 2010

# Copyright Notice

This work is the intellectual property of the author. You may copy up to 5% of this work for private study, or personal, non-commercial research. Any re-use of the information contained within this document should be fully referenced, quoting the author, title, university, degree level and pagination. Queries or requests for any other use, or if a more substantial copy is required, should be directed in the owner of the Intellectual Property Rights.

# Acknowledgements

This thesis is dedicated to Mum for her unfailing support and to Dad for instilling an appreciation of nature and craft.

To the following people I am particularly grateful:

The Vice-Chancellor of Nottingham Trent University, Professor Neil T. Gorman, who provided the bursary that funded this research project.

My supervisory team, Judith Mottram, Terry Shave and Andrew Dunn, whose knowledge, experience and patience I could not have done without.

All the test participants, who must remain anonymous in this publication.

The people who generously lent their artwork for testing: Oliver Avison, Isaac Avison, Jane Bartholomew, Amanda Briggs-Goode, Mike Ford, Stuart Grenville-Price, Bommsoon Lee, Simon Lewis, Geoff Litherland, Judith Mottram, Amanda Smith, Derek Sprawson, Alex Stevenson, Kath Townsend, Jonathan Willett.

The psychologists who provided valuable advice and papers: Don C. Donderi, Alexandra Forsythe, Paul J. Locher, Rickard Nicki and Rolf Reber.

The artists and musicians who kindly answered my questions about aesthetics and complexity: Taylor Deupree, Mark Fell and Robert Henke.

The support staff: Julie Bradshaw, Donna Swann and Melanie Bentham-Hill.

My fellow research students, especially: Jonathan Willett, Honar Issa and Matthew Malpass, for their advice, assistance and friendship.

My friends in Sneinton and beyond who have maintained my sanity (and tested it). Special thanks to Kirstie for her support in difficult times.

# Abstract

My research investigates the aesthetics of visual complexity in the practice and perception of visual art and design. The aim is to understand visual complexity in terms of the relationship between the objective properties of images and subjective properties of perception. I take a computational and empirical approach to this subject, incorporating methods from information theory, computer graphics, complexity theory and experimental psychology. For testing, I create cellular automata programs to generate stimulus images, and borrow other types of visual material from students and professional artists, designers and craftspeople. Visual complexity is measured in two ways: Firstly, an objective measure of complexity is based on the compression of digital image files, which provides an information-based scale of order to randomness. Secondly, psychophysical techniques are employed to measure the subjective complexity of the images and other aesthetic judgements. Research in complex systems theory and experimental aesthetics suggests that we can expect an inverted 'U' correlation between the two measures of complexity.

This project makes an original contribution to knowledge with empirical evidence for the hypothetical correlation of information-based and perceived complexity. With cellular automata images from simple to complex the results show an inverted 'U' correlation; the measures diverge as images approach randomness. The file compression measure fares less well with art and design images in these tests, however, perhaps because of the wide variety of visual material. Preference is more variable than judgements of complexity, and art-trained participants rated images higher than untrained participants. The implication is that although the file compression measure does not entirely correspond with human perception, the correlation we have found tells us that we can understand visual complexity as a mixture of order and chaos. A balance of complexity allows for visual exploration and pattern-finding which contributes to aesthetic value. The findings also provide a basis for creative experimentation in art and design practice.

# Contents

## Aesthetic Complexity: Practice and Perception in Art & Design

Copyright Notice .....	ii
Acknowledgements .....	iii
Abstract .....	iv
Contents .....	v

### Chapter 1

#### Aesthetics & Complexity

Introduction.....	1
Visual Complexity .....	2
Background: Art Practice and Research .....	7
Research Focus.....	10
Aesthetics .....	13
Perception .....	13
Beauty .....	14
Art and Design .....	15
Taste.....	16
The Aesthetic.....	18
Working Model of the Aesthetic .....	21
Complexity.....	24
Identifying Complexity.....	26
Computational Complexity .....	28
Cellular Automata.....	29
Mapping Complexity .....	31
Uniformity .....	34
Order and Information.....	34
Fractals .....	36
Chaos and Randomness .....	38
Complexity .....	40
Measuring Complexity.....	42
Measuring Visual Complexity.....	44
Project Outline .....	46

Planned Contribution to Knowledge.....	47
--	----

## Chapter 2

### Mapping Theory and Practice

Introduction.....	49
Aesthetic Theory.....	50
Perceptual Aesthetics.....	51
Environmental Aesthetics and Affordances .....	52
Aesthetic Theories of Art .....	55
The Open Concept of Art .....	56
The Decline of Perception in Aesthetic Theory.....	57
The Institutional Theory of Art .....	59
Visual Models of Art.....	60
Relational Aesthetics .....	64
Summary.....	66
Empirical Aesthetics.....	68
Establishment of the Field.....	68
The Measurement of Perceptions .....	69
The Measurement of Perceived Complexity .....	75
The Influence of Information Theory .....	81
Concepts from Information Theory.....	82
Visual Order and Randomness.....	84
The Influence of the Computer .....	87
The Computational Approach to Visual Perception .....	91
Aesthetic Measures .....	95
Eye-Tracking.....	95
Aesthetic Preference .....	96
Edge Detection.....	98
Fractal Measures .....	99
Data Compression.....	102
Summary.....	106
Aesthetic Practice.....	107
Simplicity and Minimalism.....	108
The Grid.....	116

Computer Art .....	119
Fractal Art .....	122
Visualizing Complex Information .....	126
Audio-Visual Art .....	132
My Art Practice.....	138
Summary of Context .....	147
Identifying the Components of Visual Complexity .....	151
Visual Complexity and Image File Compression .....	153
Locating Visual Complexity.....	155

### Chapter 3

#### Approaching Visual Complexity in Art & Design

Research Focus.....	158
Methodology.....	159
Ontology and Epistemology.....	159
Problems with Empirical Aesthetics .....	160
Philosophical Problems .....	160
Practical Problems.....	163
Methodological Approach .....	165
Methods.....	167
Quantitative Methods .....	168
Measuring Objective Complexity.....	168
Measuring Subjective Complexity.....	169
Qualitative Methods.....	170
Semi-Structured Interviews.....	170
Transcription Coding and Analysis.....	170
Plan.....	172

### Chapter 4

#### Investigating the Spectrum of Visual Complexity

Trial 1: Objective Measure.....	174
Trial 2: Subjective Measure.....	178
Test 1: Monochrome CA and Random Images .....	180
Method.....	180
Participants .....	181

Materials.....	181
Procedure.....	184
Results.....	184
Data Transformation.....	187
Analysis.....	190
File Types.....	191
Preference and Complexity Ratings.....	193
Average Responses.....	193
Influence of Art Training.....	194
Inferential Statistics.....	196
Statistical significance.....	199
Summary.....	200
Discussion: Visual Resolution.....	201
Test 2: CA and Random Images in Colour.....	202
Method.....	203
Materials.....	203
Participants.....	205
Procedure.....	205
Results.....	205
Analysis.....	206
Effect of Art Experience.....	208
Discussion.....	209
Summary.....	211

## Chapter 5

### Visual Complexity and Aesthetic Judgement

Introduction.....	212
Test 3: Images from Art and Design.....	213
Hypotheses.....	213
Test 3a: Psychology Laboratory.....	214
Method.....	214
Materials.....	214
Stimuli.....	216
Participants.....	217



Setting.....	217
Variables and Units of Measurement .....	218
Procedure .....	219
Results.....	219
Discussion .....	223
Compression Ratio.....	223
The Problem with Borders .....	224
Interviews with Participants .....	227
Interview Procedure .....	228
Transcription.....	229
Coding.....	229
Structural Coding.....	230
Pattern / Focused Coding.....	230
Results.....	233
Questions about the Task .....	234
Comfort with the Procedure.....	234
Complexity Criteria .....	235
Preference Criteria.....	239
Quality Criteria.....	242
Art Training.....	243
Comments about the Task.....	244
Analysis: Categorizing the Codes.....	245
Summary.....	248
Test 3b: Art Gallery .....	249
Method.....	249
Participants .....	249
Setting.....	250
Procedure .....	251
Results.....	251
Ranked Average Scores .....	251
Correlations .....	253
Test 3 Findings.....	255
Comparing Results between Tests 3a and 3b .....	255

Combined Results from Tests 3a and 3b .....	258
Visualizing Data.....	258
Artists vs. Non-Artists.....	263
Hypothesis Evaluation .....	264
Summary.....	265
Chapter 6	
Conclusions	
Summary of Findings .....	267
Answers to Research Questions .....	267
Focal Theory.....	268
Contextual Theory.....	269
Data Theory .....	270
Contribution to Knowledge .....	272
Implications .....	274
Measures of Complexity.....	274
Visual Information.....	277
The Spectrum of Complexity and the Window of Visibility .....	279
The Spectrum of Complexity and Colour Spectra.....	282
Maps, Measures and Models of Complexity .....	283
Impact on My Art Practice.....	285
Future Directions.....	289
References.....	292
Appendices .....	305
Appendix A: Test 1 Instructions .....	305
Appendix B: Copyright Law.....	305
Appendix C: Interview Transcript.....	306
Appendix D: List of Codes .....	310
Appendix E: Coding Results.....	312

# Chapter 1

## Aesthetics & Complexity

### Introduction

This project investigates the aesthetics of visual complexity. If you look around now, you will probably see mostly plain and simple areas (such as a clear sky or plain walls), regular patterns in smaller areas (clothing and furnishings), and perhaps some irregular patterns (carpet, grass or clouds). Besides anything living (people, pets and plants), the most complex visual things around are probably objects of aesthetic value. Why artworks tend to be complex, and how visual complexity relates to aesthetic value, are the questions I aim to answer in this research.

The first chapter outlines the scope and direction of the research. It begins with a general introduction to its focus – the aesthetics of visual complexity. This includes an account of the personal context for the research, including a brief description of previous academic work and the art practice from which the current research developed. My art practice uses computational models from complexity theory as creative tools, and it supports the current project as a source of visual material. Before the contextual literature review in Chapter 2, it is necessary to clarify the meanings of *aesthetics* and *complexity*. The context of the project can be described as the intersection of these two fields. They are dealt with in two sections in Chapter 1 which summarise the development of the fields, delineate their main concerns and offer definitions of terms which are used throughout the thesis. The section on aesthetics also introduces a working model of the aesthetic which is used in the thesis as an explanatory and analytical tool. This preliminary discussion of the contextual theory serves to outline the project and develop its research questions.

Some of the most significant issues are identified earlier in Chapter 1, and are discussed further throughout the thesis. Chapter 2 presents a review of contextual theory and practice in the field of aesthetics. It is divided into three sections, covering theoretical contributions to the field, empirical investigations, and creative aesthetic practice. Chapter 3 identifies the methodology of the project and outlines the chosen methods. Chapter 4 comprises the initial empirical investigations, which focus on the visual complexity of stimuli based on images of cellular automata programs. The purpose of these tests is to examine a broad range of visual information in order to obtain an overall picture of the spectrum of complexity. An initial contribution to knowledge is made by extending the range of visual complexity under investigation with the chosen methods. The tests in Chapter 5 develop the findings of the earlier tests and focus on images from contemporary art and design practices. Chapter 6 summarizes the results and describes how the tests contribute to knowledge by extending the psychological and computational methods into the field of art and design. An original contribution to knowledge is made with empirical evidence for a perceptual threshold of visual complexity: Perceived complexity describes an inverted U-shape correlation with visual complexity as measured by image file compression. In conjunction with measures of aesthetic perception, the information-based measure reveals that complexity can be understood as a balance of order and chaos.

## **Visual Complexity**

*'A variety of patterns at different levels'* is a reasonable preliminary characterization of visual complexity. For example, a painting exhibits patterns at many levels: Below the range of our perception, patterns of protons, neutrons and electrons form specific chemical elements which combine into hundreds of different molecules in the pigment, binder and support. The mechanical and optical properties of these minerals, oils and fibres determine the painting's construction by the artist and its appearance to the viewer. At the visual level their crystalline, fluid and woven textures combine to form a record of the artistic process which is revealed in the layers of paint and the traces of brushstrokes (Figure 1).



Figure 1 Titian, *The Martyrdom of Saint Lawrence* (1548–1557), oil on canvas (cross-section, magnified  $\times 120$ ). This section, from part of a figure in a red cloak, reveals layers of red lacquer and particles of carbon black, lead white and cinnabar pigments in oil. The opaque white layer reflects light that reaches it through the translucent red glaze, intensifying the surface colour.

On the surface of a painting we perceive forms, which may be abstract or representational, well-defined or ambiguous. These forms have colour, texture and position relative to each other and to the whole picture. The way that these formal relations have been handled by the artist may be recognised as a style. From the visual level, we may notice themes in the content of the work – that which is signified implicitly as opposed to being represented explicitly. We may also perceive the relation of this particular work to the artist's oeuvre, and see how it fits the pattern of the artist's output. Similarly, we may see how the work relates to its genre and the rest of the art world, to art history, and if not also to current political or philosophical concerns, then almost certainly to our own experience. These are all examples of various patterns at different levels in a painting, and each of them has a bearing on the perception and judgement of visual art. The perception of these complex aesthetic patterns and their inter-relations provides the basis of our understanding and appreciation of visual art and design. At the centre of them all is the level of visual perception, and this is the focus of the current research project.

In common with this project, Rudolph Arnheim's book *Art and Visual Perception* (1974) employs psychological findings to contribute to understanding the aesthetic perception of art. Using Gestalt psychology, Arnheim explains how we derive meaning from our sensory impressions. Gestalt means 'complete form' in German, and the theory consists of laws that describe how we perceive whole shapes by grouping individual sensory elements. We make sense of art by perceiving forms and patterns from pictorial elements that coexist in a hierarchy of visual levels. Arnheim describes this kind of aesthetic comprehension as an attempt to derive generalities from the particular in a work of art, a task which is

... laborious, but not different in principle from trying to describe the nature of other complex things, such as the physical or mental make-up of living creatures. Art is the product of organisms and therefore probably neither more nor less complex than these organisms themselves. (Arnheim, 1974 p.2)

Arnheim suggests that art is as complex as the beings that create it, but how does this complexity arise? The complexity of living beings stems partly from an accumulation of evolutionary history, in a progression from simple bacteria to complex social animals. The parts and mechanisms that endow beings with the property of life are among the most complex things we know, and they also provide some of the richest visual material, as anyone knows who has tried to paint flesh, fur, feathers or foliage.<sup>1</sup> Therefore, one source of complexity in art is the pictorial representation of these visually-complex beings. Non-living things, on the other hand, tend to be simpler in construction and in appearance. Amongst both living and non-living things, some of the most common forms of naturally-occurring pattern are fractals (Figure 2). These self-similar patterns can be seen in clouds, ferns, coastlines, lightning, snowflakes, and trees (Figure 3).

---

<sup>1</sup> Drawing and painting can offer a deeper understanding of the visual world than, say, photography, because they involve a hands-on *re-creation* of perceptual objects and effects. To draw (make) a picture of a scene is to draw (take) visual information from it.

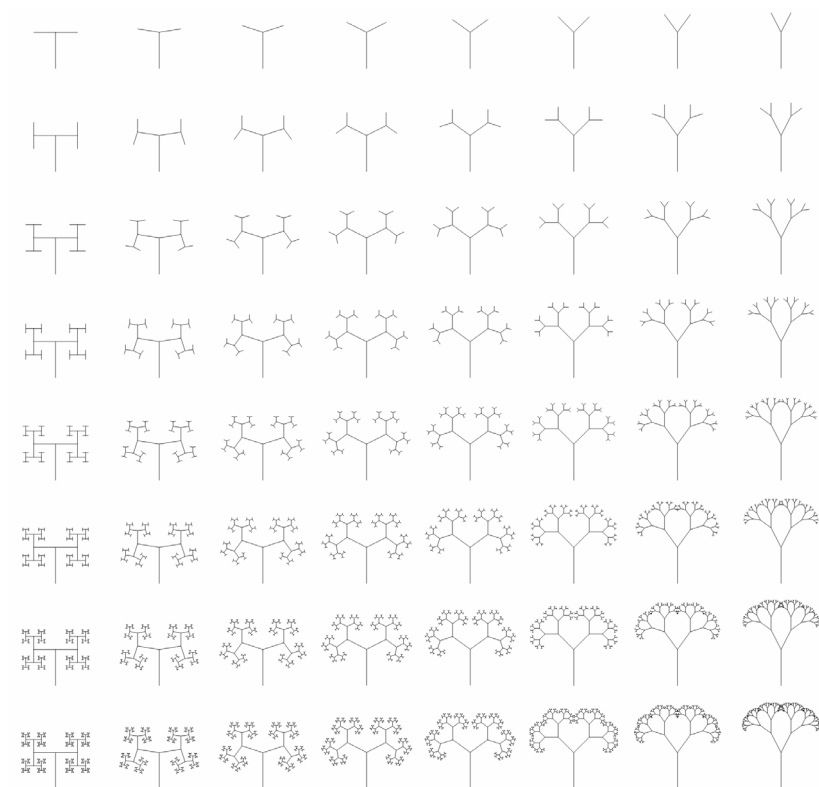

Figure 2 Artificial fractals. These images show variations of two parameters: branching angle (left to right), and number of branches (top to bottom).



Figure 3 Natural fractals: branches and leaves of oak and beech trees.

Images of fractals are less common in art than they are in nature. Unlike art, which often has a variety of different patterns, a fractal image has the same pattern at all levels, so it can be described more succinctly, and is less complex. Artificial fractals are a little less complex than natural fractals because they tend to have more regularity, whereas natural fractals do not repeat exactly, which makes them more complex, and visually more interesting. Images of natural fractals have even been shown to reduce physiological stress (Taylor, 2006). Nevertheless, despite this particular physiological benefit they have less aesthetic value than works of art and design, which are generally more complex. For example, Mandelbrot (2004a) notes that Hokusai's *Great Wave off Kanagawa* (Figure 4) is striking partly because it is one of the earliest visualizations of natural fractals in art, but what makes it more visually interesting is that it also has plain areas, repetitive patterns and irregular shapes. My hypothesis is that visual complexity sustains interest in an image by allowing our visual system to engage in pattern-finding and interpretation. The images that provide the richest visual information for this perceptual interest are those with a variety of patterns at different levels. In general, then, artworks are more complex than clouds, but by how much? That is what the project aims to find out.



Figure 4 Katsushika Hokusai, *The Great Wave off Kanagawa* (1829–1832), woodcut print.



To find out how complex art is, we need a way of measuring visual complexity. Arnheim gives us a clue as to how we might begin to make these measurements – through a process of description. For example, we could start by listing the visual elements in an image and their formal properties. Instead of a purely qualitative approach like Arnheim’s, however, this project employs concepts from information theory to formalize a model of visual complexity and support a quantitative analysis of images. With a quantitative approach, the *size* of a description provides a basic measure of complexity, since something that is more complex takes longer to describe. In this project, the ‘descriptions’ are based on digital image files, which allows for a computational analysis of aesthetics. Conceptual tools from complexity theory and techniques from experimental psychology are brought to bear on this computational approach to visual complexity. In this way, we can proceed to investigate the relation of complexity to the perception and understanding of visual art by using quantitative measurement of objective and subjective aesthetic properties as a basis for carrying out tests on a variety of images. How we choose to select or create images for the tests will be critical to interpreting the data (a matter discussed further in Chapter 3), but what is most important for this study is that the material should represent a range of visual complexity and reflect contemporary visual art practice. The next section briefly describes the role of my own art practice in developing and supporting the current research focus.

## **Background: Art Practice and Research**

I am led to this research by my interest in the natural world and our relation to it through art and science. I have always been fascinated by the aesthetic experiences of art and nature, and by the way that scientific understanding enriches aesthetic perception. During my first degree, a lecture on the concept of entropy in art led me to investigate the science of chaos. Part of the appeal lay in the images used to describe these processes, which came from computational models, so I began to explore ways of using these models as tools for visual creativity. This was my introduction to cellular automata – programs

composed of many ‘cells’ that interact according to simple rules to produce surprisingly complex behaviour. Because cellular automata are easily visualized on grids, these programs now form a significant part of my art practice, and they are used extensively in this project. At first I calculated the programs by hand and then later on computers, but of these early experiments the only exhibited works were needlepoint pieces (Figure 5). Images of these new computational tools from complexity theory could look dated on digital screens and prints, but as hand-stitched artefacts they were more original and more visually interesting.

From the use of craft techniques to visualize computational processes, my master’s degree involved an examination of craft and its relation to fine art. For this work, however, I rejected the use of a computer, for two reasons: Firstly, *calculating* the programs by hand makes the point that complex patterns can be generated by very simple processes (a computer just speeds things up considerably), with the artwork itself acting as visual evidence. Secondly, *making* the pieces by hand, instead of mechanical or digital production, gives a more appealing visual quality – the ‘aura’ of an original artefact. Small imperfections and natural variations increase the formal complexity of the surface pattern, resulting in a visual characteristic similar to the appealing irregularity of natural fractals. This led to a re-interpretation of Walter Benjamin’s (1936) concept of aura in aesthetic terms, and to the realisation that in digital reproduction there is no change in aura, unlike in mechanical reproduction, since digital copies are exactly identical. The study culminated in the suggestion that the visual appeal of the hand-made is a result of the enriched complexity of surface pattern that comes with manual techniques compared to mechanical or digital production. In relation to this conjecture, the current project explores the more general question of how visual complexity relates to aesthetic value.

Looking at the needlepoint pattern in Figure 5, it is not obvious *how* it is designed, but it is apparent that it *is* designed and not just the result of chance occurrences. The appearance of living things has a similar kind of visual property, which sometimes leads to the misconception that they too are designed rather than the result of a complex

evolutionary history. In fact, the needlepoint pattern is based on a cellular automaton program of just a few simple rules, which starts from a single stitch and gets progressively more complex.

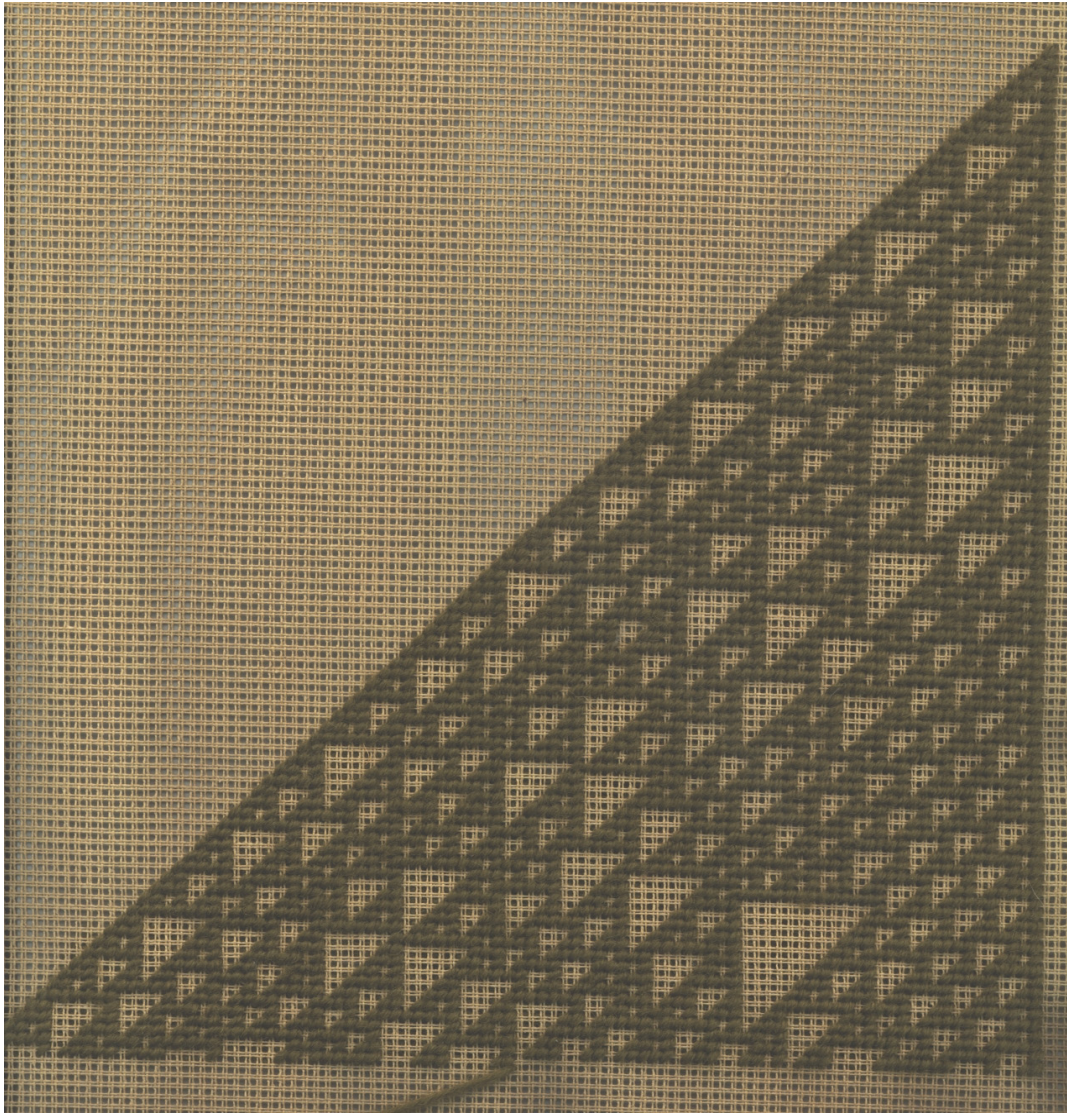

Figure 5 *Elementary Cellular Automata #110* (2003), needlepoint (detail, work in progress).

In complex systems theory, Stephen Wolfram (2007) and Stuart Kauffman (2003; 2008) argue that the value of computational models such as cellular automata is that they offer an explanation for the complexity of life on earth that complements the explanatory power of Darwinian evolutionary theory, which by itself does not account for many of the complex structures we see in nature: “...the snowflake’s delicate sixfold symmetry tells us

that order can arise without the benefit of natural selection” (Kauffman, 2003 p.47). My understanding is that although Darwin’s theory explains the mechanism by which particular phenotypes are *selected* over others, it fails to explain how their complex structures are *generated* in the first place.

I consider the attraction of visual complexity to be similar to the appeal we find in natural forms, which are neither too ordered and dull, nor too chaotic and confusing. My inference is that they hold our interest because their perceptible organisation invites a visual exploration which engages us aesthetically. The formal structure of an image is what is represented by the concept of visual complexity. In general, a more complex image provides a more fertile ground for visual exploration. Therefore, images that are too complex to understand in one glance invite us to look again, but unless they repay further exploration by offering a meaningful relation of visual elements (as opposed to a random arrangement), we are likely to lose interest. I suggest that visual complexity is what holds our attention, once it is captured initially, by affording an opportunity to exercise our powerful visual senses.

## Research Focus

I am not only interested in finding out what visual complexity *is*, but also what it *does*. So in addition to studying objective formal properties, the project also aims to investigate the subjective perception of visual complexity, in order to create a balanced study of both sides of the aesthetic. We need to establish what it is, however, before we can look at what it does. Therefore, measuring visual complexity and determining its formal properties, as an initial step, provides a route to understanding how it is produced by the artist and perceived by the audience. From this starting-point, the research questions are formulated. To describe the stages of research, I have adapted the model of Philips & Pugh<sup>2</sup> (2000): Firstly, the *focal theory* sets out a plausible argument for the scope and purpose of the

---

<sup>2</sup> Philips and Pugh’s model comprises four similarly-named categories – *focal theory*, *background theory*, *data theory* and *contribution* – with a slightly different emphasis on the content of the research stages.

project; *contextual theory* comprises a structured critique of relevant material and a mapping of the field; this leads to the *data theory*, which justifies the methods, details the test procedures and presents the results; finally the *contribution* interprets the results, identifies their contribution to knowledge, and discusses the impact of the findings for the field. These stages are discussed in more detail next, and are summarised in the form of research questions at the end of this chapter.

The project focus is based on the premise that visual complexity is a significant aesthetic element in the creation and perception of art and design. The hypothesis is that visual complexity provides a ground for visual exploration (pattern-finding and interpretation) that sustains interest and contributes to aesthetic value. Whereas too little complexity (such as simple repetitive patterns) can be uninteresting, and too much complexity (chaos or randomness) can be confusing, we tend to find a middle ground of complexity in the images that hang in our homes and galleries. From this initial observation, we arrive at the two-sided question of what makes visual complexity aesthetically valuable, and why valued aesthetic work is often visually complex. This can be re-formulated into a single research question for the focal theory: What is the relationship between visual complexity and aesthetic value?

We can begin to develop a structured answer by measuring visual complexity and aesthetic judgements of a set of visual artefacts. Once a suitable measure of complexity is established, having tested it for feasibility, the aim is to proceed through a series of empirical tests on images of varying complexity. A statistical analysis of the data will determine the correlation between measures of complexity and its perception, and give us a quantitative answer to the question of aesthetic value and visual complexity. In addition, qualitative methods can inform these results through interviews with test participants. Due to the practical difficulty of being able to represent and measure the visual properties of three-dimensional artefacts, the study is limited to two-dimensional visual material.

To support this line of enquiry, we need to develop a theoretical base by reviewing literature from the field and mapping the practices that form the context of this project. This stage constitutes the contextual theory of the research. Primarily, it involves an examination of contemporary aesthetics to determine current knowledge of the perception of visual complexity. This material includes not only the traditional philosophical side of aesthetics, art discourse and art practice, but also recent scientific contributions from the emerging field of empirical aesthetics. The early stages of this project identified that the majority of publications on visual complexity come from scientific fields. Amongst these diverse topics are: visual development in infants, mapping whale behaviour patterns, and optimising the readability of radar images and naval charts. The review of empirical aesthetics necessitates a brief summary of information theory, which underpins the techniques from experimental psychology and digital image processing that form the basis of this project's methods. In addition, the literature review covers aspects of complexity theory that pertain to visual perception, and examples of visual art practice that engage with or manifest aesthetic complexity. These examples of practice are not limited to the most complex artworks, but include artefacts and designs that represent samples from a wide spectrum of visual complexity, from minimalism to *horror vacui*.<sup>3</sup> The contextual review answers the question of what is known about the aesthetics of visual complexity, and with what methods this knowledge can be acquired.

With the contextual theory in place, we are able to make decisions about the data theory and its research methods: in this case, how to measure the complexity of an image and the aesthetic judgements of a viewer. Once the methods are selected and trialled, we can start to design the tests and prepare the necessary apparatus. Only then can we begin to acquire our data and start the analysis, from which we will be able to determine the complexity of the visual artefacts, and how their visual complexity relates to aesthetic judgments. The final analytical stage evaluates the tests according to the methodology,

---

<sup>3</sup> In an artistic composition, *horror vacui* is the absence of empty spaces (literally 'fear of emptiness').

allows refinement of the procedures, and develops a sustained line of enquiry between the experiments. Knowledge structured from the contextual research is used to interpret the results and is re-evaluated in light of the project's findings. A final summary assesses the impact of the new results on the field, identifies remaining gaps in knowledge, and highlights potential areas for extending the research in the future.

## Aesthetics

Before we go any further into the details of this project, it is necessary to clarify its context to provide a foundation for the remaining research. The focus is visual complexity – how it is used by artists and designers and perceived by an audience. Its context, therefore, consists of the areas in which the making and perception of art are analysed and discussed. These areas are united by the term *aesthetics*. The following section examines the development of aesthetics as an academic discipline, identifying its central issues and elaborating their relevance to this project.

### Perception

The word 'aesthetic' has its origins in the ancient Greek *αἰσθητά* (*aestheta*), meaning 'things perceptible by the senses', as opposed to *νοητά* (*noeta*) – 'things thinkable or immaterial' (OED, 2009). 'Aesthetic' is an adjective, whereas 'aesthetics' is the name for the field of study concerned with aesthetic experiences and aesthetic properties. The field acquired this modern meaning primarily from Alexander Baumgarten's use of the word in his two-volume book *Aesthetica* of 1750/1758: "things known are to be known [...] as the object of logic; things perceived are to be known [...] as the object of the science of perception, or aesthetic" (Baumgarten, in: Bennett, 1996, p.47). At that time, the idea of aesthetics as a science never really took hold, but the word stuck with what had already become a philosophical discipline that centred on questions relating to *perception*.

Sensory perception has a variety of modalities. The traditional division of the senses into five categories represents the individual natures of these modes of perception: vision,

hearing, smell, taste and touch. This list of five appears to be based on the visible sense organs: eyes, ears, nose, mouth and skin. Science now shows that each of these organs is the receptor part of a sensory system that includes specific neural pathways and areas of the brain. An alternative way of categorizing the senses is by the type of stimulus, which we could reduce to three: mechanical (hearing, touch), chemical (smell, taste) and electromagnetic (vision). Perceptually, though, we experience more than five sensory modes, including temperature, pressure, hunger, pain, balance, and spatial orientation. The categorisation of sensory modalities is sensitive to the description of their objective and subjective features, and therefore it is critical to a study of perception, especially one that tries to relate the physical properties of objects to subjective sensory perceptions. In the contemporary scientific study of perception, this field is known as psychophysics, and it provides a basis for the methods in the current project. We will see later on in the contemporary literature how sensory modalities are treated in relation to aesthetic questions. Some of the themes explored relate to general issues that apply to all sensory modes of the aesthetic, but the primary concern of this project is with the perceptual aesthetics of *vision*.

## Beauty

When we turn our attention to the senses, one of the first things we notice is that some perceptions are pleasing and some are not. Our name for this sensory pleasure is beauty, and the objects or events from which this pleasure is derived we call beautiful. The concept of beauty provided a foundation for aesthetics as a discursive practice that can be traced from Plato and Aristotle to the beginning of the nineteenth century. Initially, beauty was considered to be a property of objects that is revealed to us via the senses. In Plato's aesthetics, for example, beauty is an ideal (transcendental) form of reality that is actualised in objects to greater or lesser degrees: God *designs* forms, nature or craft *makes* them, whilst art *represents* these things. Plato denounced art because he regarded it as mere imitation of objects that are themselves imperfect manifestations of beautiful ideal forms; thus art is at a



‘third remove from reality’. In this ancient Greek thought, we see the beginnings of aesthetics as being concerned with the core subject of perception via the concepts of art and beauty.

As the discipline of aesthetics develops, the idea of beauty is gradually transformed from being an objective property of artefacts to a subjective property of perceptions. In the eighteenth century, the aesthetics of philosophers in the midst of this transformation – such as Shaftesbury, Hutcheson, Burke and Hume – are partially subjectivized, but still remain rooted in objective formal properties (Dickie 1971, p.30). By the nineteenth century, beauty no longer resides in the object but ‘in the eye of the beholder’. The philosopher Arthur Schopenhauer, for example, thought that anything can be beautiful – it just depends on directing aesthetic attention, and William Blake said “Every eye sees differently. As the eye, such the object.” (Frye 1969, p.19). The objective-subjective duality of perception remains closely connected to issues in contemporary aesthetics, and has a bearing on the current project in its methodological choices and interpretation of results. This project does not focus on the concept of beauty *per se*, but it does investigate subjective aesthetic judgements of preference (how much an image is liked) and quality (how good a work of art is) in relation to the perception of visual complexity in art.

## **Art and Design**

Aesthetics is naturally associated with the practices of art and design because the arts are understood to involve objects and events that please the senses. So in addition to questions about perception in general, aesthetics uses concepts such as beauty to explore questions about the perception of visual art and design. This broad category of aesthetics is also known as the philosophy of art. Art affords aesthetic experiences by presenting perceptible properties. Aesthetic theories of art attempt to explain how we experience, understand and evaluate this visual material. Consequently, aesthetics brings together science and philosophy in the study of the arts. This makes the aesthetics of art a far-reaching discipline whose area of study can be approached from many different angles, and

makes for a place of lively debate. How well-integrated are its different areas, and the extent to which communications between them flow, is presented in the contextual review that follows this chapter. For now, we note that this combination of art, science and philosophy means that the aesthetics of art has the potential to be a truly inter-disciplinary field. The current project is designed to integrate creative, empirical and critical research methods in an investigation of the aesthetics of visual complexity.

A central occupation of philosophical aesthetics is the definition of art, which can be divided into two distinct functions: classificatory and evaluative. While the former relates to the conditions that make an artefact a work *of art*, the latter deals with what makes a *good* work of art. Evaluating aesthetic objects in these terms is fundamental to the practices of art and design. For aesthetic philosophy, therefore, the *criteria* for such evaluations provide a basis for defining art practices and products. Inasmuch as the definition of art relies on *criticism* rather than art objects, the aesthetics of art constitutes a form of meta-criticism. The discourses of art and its aesthetics thus run parallel in a similar way to that of literature and literary criticism – their readerships are quite different (and this is perhaps why so many books on visual aesthetics have so few illustrations). There was a time when the Western concept of art was limited to so few practices that it was a relatively easy task to identify a work of art amongst other objects. Today the range of practice is much wider, and the criteria employed by artists, critics, buyers and curators are less easy to identify. In an artworld that supposedly accepts any kind of object or event as a candidate for art status, being able to recognise and use these criteria is a basic requirement for engaging in its practice and discourse. We see in Chapter 2 how this situation is addressed in the contemporary philosophy of art and design.

## **Taste**

In the 18th century, the concepts of beauty and taste occupied a central place in aesthetics, not only in the philosophy of sensory perception but also in the philosophy of art. At this time, the meaning of ‘aesthetic’ is further developed by Immanuel Kant in the

*Critique of Judgement* (originally published 1790). Kant restricted its use to denote matters of taste, that is, the *judgement* of sensory perceptions (Levinson, 2003). He begins his analysis by saying, “The judgement of taste is not cognitive [...] and so not logical, but is aesthetic – which means that it is one whose determining ground *cannot be other than subjective.*” (2007, p.35, original emphasis). It is the subjective aspect of aesthetic judgement that distinguishes it from judgements of reason and ethics (which had been treated in two previous critiques by Kant) and that defines the aesthetic as a judgement of taste. Kant describes four types of subjective judgement: the agreeable, the good, the beautiful and the sublime. Judgements of the agreeable and the good are both ‘interested’ (tied to desires), whereas judgements of the beautiful and the sublime are not, and on this basis they are defined as aesthetic judgements of taste:

Taste is the faculty of judging an object or mode of representation by means of a delight or aversion *apart from any interest.* The object of such a delight is called *beautiful.* (Kant 2007, p.42, original emphasis).

Here, the concept of beauty is employed by Kant to distinguish judgements of taste from rational or ethical judgements. At this point in 18th century aesthetics, beauty has become a tool of philosophical inquiry rather than a constraint to its focus. In Kant’s emphasis, besides beauty, we also find the first conception of aesthetic judgement as being disinterested, which is one of the defining characteristics of his aesthetic, along with subjectivity and universality. This formulation of aesthetics is amongst the most influential and long-lasting, but the concept of taste loses favour in aesthetic discourse as it comes to be associated with the privileged power relations of authoritative institutions and individuals.

Today, ‘taste’ is a term rarely used in talking about art. In a contemporary artworld in which the aesthetic judgements of gallerists and curators apparently have a great deal of influence (as evidenced in *Art Review*’s annual ‘Power 100’ list, for example), it is perhaps worth re-evaluating the concept of taste and re-introducing the term in today’s art

discourse. I believe that the concept of taste still has currency in the production and consumption of aesthetic material, whether it is talked about or not. It would explain the success of those who make a living based on their judgement and selection of aesthetic material, such as D.J.s in dance music culture who may develop a higher profile than many of the artists whose work they present. It would also explain the almost reverential attitude towards figures such as the late radio D.J. John Peel, whose listeners trusted his judgement and were willing to appreciate (or endure) the various types of new and experimental music that he was known for championing. Ostensibly, the *purpose* of a critic is to proclaim what is good and what is not, but the *value* of a critic's function improves as we get to know their taste, whether we share it or not. We could say similar things about the job of the curator. As the roles of artist and curator become increasingly blurred in contemporary practices, such as that of Nicolas Bourriaud, whose role we could describe as a D.J. of the artworld (see *Postproduction*, 2005), aesthetic judgement remains a significant element in the day-to-day transactions of art, whether or not we choose to call it 'taste'.

## The Aesthetic

As the concepts of beauty and taste lose currency in aesthetic philosophy, they are gradually replaced by discourse about what defines the aesthetic. In language, 'aesthetic' serves as a predicate to a particular kind of experience, object, property, concept or judgement. In trying to construct a definition of the aesthetic, philosophy attempts to clarify the relationship between these various aspects and to identify which is the most fundamental. Nick Zangwill (2008) argues for the primacy of aesthetic judgements, as follows:

Aesthetic properties are those that are ascribed in aesthetic judgments; aesthetic experiences are those that ground aesthetic judgments; aesthetic concepts are those that are deployed in aesthetic judgments; and aesthetic words are those that are typically used in the linguistic expression of aesthetic judgments.

Nevertheless, it is plausible that aesthetic *concepts* are more fundamental, because if they are 'deployed' in aesthetic judgements, then they must be prior to and independent of

those judgements, and aesthetic language too. On the other hand, one could also argue for the primacy of aesthetic *experience*, without which there would be little to discuss at all. With the current project's focus on perception, aesthetic experience is perhaps the more fundamental, but actually this matter is not directly relevant to the project because it has little practical consequence in terms of its methods. What is most significant is the fact that all these aspects of the aesthetic are closely interconnected, and we should be mindful of their relationships in our analysis of visual complexity.

Kant's concept of the aesthetic is defined by disinterestedness in practical desires except for an appreciation of the aesthetic experiences that art affords. Kant describes his aesthetic as *subjective* (personal) and *universal* (normative) (2007, p.42). When we make an aesthetic judgement, it cannot be anything other than subjective because it is not based on reason or ethics, but at the same time it is also an evaluation. In this sense, aesthetic judgements are not just explicit statements of preference; implicitly they are universal invitations for others to agree with us. If we say "I like this wine", we make what Kant called a judgement of agreeableness, but if we say "that painting is beautiful", we make a judgement of taste. We make such a statement *as if* beauty were a property of that painting, even though we also know it as a judgement based on subjective experience. To state that one likes something is a claim beyond dispute, but to state that something is beautiful is to make a claim that can be argued against. Aesthetic judgements are thus normative because they make this claim to truthfulness. Unlike objective universal judgements, which are based on shared concepts or criteria, aesthetic judgements are grounded in personal experience. Kant's normative aesthetic forms a central element of analytical philosophy, but in continental philosophy the subjectivity of aesthetic judgement undermines its claim to truth, which leads to the denial of normativity and to the view that all such judgements are only 'relative'. We return to this issue in the methodological discussion in Chapter 3, but for now we note that the current project rejects the continental view and accepts the normative aspect of the aesthetic.

In philosophical terms, aesthetics tries to define the *necessary* and *sufficient* conditions of the aesthetic, that is, to identify *all* the properties that things *must have* to be properly called aesthetic. An example of this approach is that of Monroe Beardsley (1958), for whom the value of an aesthetic experience depends on having three properties: unity, intensity and complexity. For Beardsley, these three properties are the ‘essences’ of the aesthetic. The value of this essentialist approach is that it has the potential to say whether an artefact is aesthetic and why it is worth looking at, but its usefulness crucially depends on its relation to actual practices in the artworld. From Kant onwards, the field had become focused on essentialist definitions of the various aspects of the aesthetic (experiences, properties, etc.) and of art. By the 1950s, the increasing diversification of art objects and the development of new practices strained the relationship with essentialist definitions of art. Similarly, perceptual definitions of the aesthetic also suffered amidst an increasingly conceptual artworld. Beardsley’s aesthetic straddles the division between the theory discussed thus far and the theories dominant in contemporary aesthetics, which are examined in the following chapter. The dividing line is marked by the influence of Wittgenstein, who challenged the philosophical practice of essentialist definition. Beardsley’s (1958) theory represents the first response to the neo-Wittgensteinian challenge – to avoid defining art at all (he only defined the aesthetic). We take up this discussion in the next chapter, beginning with the more constructive responses to this challenge.

To summarise this preliminary discussion of aesthetics, we can say that the field is chiefly concerned with *perceptions* (which are natural phenomena), *properties* (of art and nature), and *practices* (of making, perceiving and understanding art). The field is divided along the lines of the various methods employed in its study and the purposes for which those studies are undertaken. Here we have introduced the philosophy of aesthetics, and have focused on the discursive tradition of this field. In the next chapter we develop this line of enquiry into contemporary culture, and expand the context into the artistic and scientific explorations of the aesthetic. Broadly speaking, all aesthetics is connected with

the study of perception, since almost everything we know comes to us via the senses, but discourse in the philosophical field has shifted – in parallel with art practice – from the perceptual to the conceptual. This move seems to be out of line with a contemporary cultural environment that is increasingly designed to be perceived, and in which there appears to be a tendency towards the aestheticization of everyday objects. The aesthetics of technological products, for example, is now considered much more than it used to be. Dieter Rams’ designs for Braun led the way in this regard; the third of his ten design principles is ‘good design is aesthetic’ (Design Museum, 2007). Jonathan Ive presently continues the trend with sleek, functional and colourful designs for Apple Inc., such as the *iMac*, *iPod* and *iPhone*. Given this situation, perhaps aesthetics should look again at how we sense and make sense of the surrounding visual culture, in order to understand a little more about why we appreciate the things that we do in terms of perception. This is one motivation for the current project – to re-evaluate perceptual aesthetics in general, but to focus specifically on the property of visual complexity in the practice of art and design.

## **Working Model of the Aesthetic**

I now present a model of the aesthetic that provides the conceptual framework for this project (Figure 6). The model is based on three key elements – artist, artwork and audience – from which a fourth element is developed – the artworld. These elements provide an ontological base for the thesis that allows for the identification of the aesthetic. Of these four the artwork is the primary element, but it is also important to recognise that behind every artwork is an artist, and in front of the work there must be an audience. Including these roles reflects the position that unless an artist engages with the artworld public, an artefact cannot lay claim to being a work *of art*. That the audience contributes to an artwork is a well-established principle, as described by Marcel Duchamp in his lecture *The Creative Act*, 1957:

All in all, the creative act is not performed by the artist alone; the spectator brings the work in contact with the external world by deciphering and interpreting its inner qualification and thus adds his contribution to the creative act. (Stiles & Selz, 1996, p.819)

In addition, the model illustrates the idea that art is essentially a form of communication, and that whatever the medium it always carries a message. The arrows in the illustration signify both the direction of communication and the temporal sequence of the process. Communication is an essential element of art, but the current project does not focus on interpretation and meaning; it is less concerned with *semantics* than with the *syntax* of visual complexity. The scope is limited to the aesthetic perception of visual complexity, a formal property of the art object, which is why the artwork is central to this model.

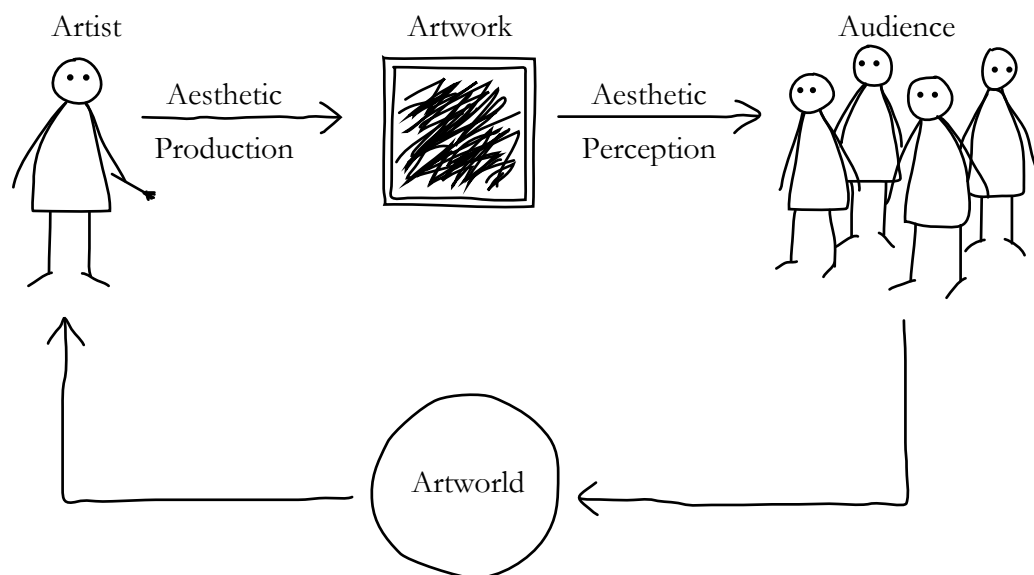

Figure 6 The working model of the aesthetic.

In this model, the aesthetic is identified as residing in the interactions with an artwork – firstly by those who produce it and secondly by those who perceive it. The aesthetic is an active process of experiencing art and making judgements based on the evaluation of those experiences. The artist uses her judgement in the production of an artwork to make decisions about how the creation of the work should proceed. More often than not, this involves a kind of continual adjustment until the aesthetic properties of the artwork meet the requirements of the intended aesthetic experience that the work is to



afford the audience. In turn, the audience makes aesthetic judgements about an artwork and the artist based on their sensory perceptions, which include the most basic judgement of whether to continue looking or not. This project's hypothesis is that visual complexity sustains aesthetic interest in looking by providing a ground for visual exploration.

Together, the processes of production and perception constitute the artworld – the culture in which art is made and appreciated. In this conceptual model, the artworld is comprised of many such processes of aesthetic production and perception. Figure 6 shows only a single artwork for the sake of clarity, but the model symbolizes many artists producing multiple artworks which are seen by lots of people in various times and locations. Each of these historical or potential situations constitutes a unique context for the perception of an artwork which affects the quality of aesthetic experience it affords. The model does not attempt to represent this kind of detail, but it is implied. Also implied are the many other roles besides artist and audience that populate the artworld, such as curator, critic, dealer and gallerist, to name but four. Instead, the model focuses on the core structure of art practice and is centred on the artwork. We return to the model in Chapter 2, where it is used to structure the methodology, and in Chapter 3 it provides an analytical tool for aesthetic theory.

A key part of the model is the location of the aesthetic in the interaction between object (artwork) and subject (artist or audience). This objective-subjective duality is present in many aspects of the aesthetic described thus far – attributes of sensory modes, aesthetic properties, theories of art, and so on – and the way in which we deal with this issue affects the nature of the investigation. The current project investigates visual complexity in both objective and subjective terms, and the relation between these two aspects of the aesthetic is a significant element in the development of this thesis. The focus of the thesis can be described as the intersection of the fields of aesthetics and complexity. Having introduced some key concepts of aesthetics, we next take a look at complexity.

# Complexity

First, a word about terminology: ‘Complexity’ stems from the Latin root *plexus*, meaning ‘plaited’ or ‘woven’, and so *complex* literally means ‘plaited together’ or ‘interwoven’ (OED, 2009). In aesthetic terms, what is woven together are the various patterns at different levels that are available to visual perception, which we described at the beginning of this chapter. In this thesis, the term ‘complex’ carries its usual meaning as the opposite of ‘simple’. Complexity comes in degrees, however, and the thesis explores visual complexity as a scale from simple to complex. So while ‘complex’ generally refers to one extreme of this scale, ‘complexity’ can refer to the whole range. Similarly, ‘complexity theory’ is a term used to describe many different areas of study, some of which focus only on the most complex phenomena whilst others investigate a wide range of complexity. This project explores a wide range of visual complexity. To avoid ambiguity I occasionally refer to this range with the phrase ‘spectrum of complexity’.

By looking at how complexity is understood, we may begin to learn more about its manifestation in visual art and design. In this way, the scientific literature on complexity can contribute to understanding its production and perception in art. The objects of study in this field of science are complex systems. One of the first people to propose a definition of complex systems was the economist Herbert Simon, who in 1969 described them as being “made up of a large number of parts that have many interactions” (1996, p.183). Examples of complex systems include an ants’ nest, the stock market, the weather system and the brain. Each of these systems displays some kind of autonomy from the workings of its constituent elements. For example, we do not find the blueprints for the ants’ nest in any individual, and yet it emerges in their collective behaviour. Similarly, many people have tried to find rules that characterize the behaviour of a stock market, the pattern of which depends on many variable interactions of individual brokers, bankers and businesses. In contrast to these examples, the objects of study in the current project are two-dimensional artworks, and these are not complex systems. The artworks under investigation are static

objects, not dynamic systems. The implication is that what we can learn from complexity science may be limited by the scope of the project.

Visual complexity does involve complex systems, however, in its perception. Perceiving visual complexity requires very complex structures (the visual system) and produces complex phenomena (conscious sensory awareness), but the project focus is limited to the formal complexity of visual images, and not the complexity of these biological and psychological mechanisms. Therefore, whilst some of the dynamic aspects of complexity theory may be inapplicable to this project, we may yet find use for some of its concepts and models. Indeed, one of the central concerns of complexity science is to unearth patterns of behaviour that are common to many different systems, such that understanding mechanisms of complexity in one type of process may inform activity in other fields. The proof of the applicability of such concepts to other fields is the responsibility of each individual researcher, and it often requires an element of faith or intuition to begin such an investigation. Nevertheless, there are suggestions that it is possible, at least in principle, such as this comment by Herbert Simon which also supports the hypothesis of the current project: “The aesthetics of natural sciences and mathematics is at one with the aesthetics of music and painting – both inhere in the discovery of a partially concealed pattern” (1996, p.2). For the purposes of the present study of visual complexity,

The field of complex systems provides a number of sophisticated tools, some of them concepts that help us think about these systems, some of them analytical for studying these systems in greater depth, and some of them computer based for describing, modelling or simulating these systems. (Nicolis & Rouvalis-Nicolis, 2007)

The aim of this section is to present some of the *useful concepts* that can help us think about visual complexity in preparation for the contextual review in the next chapter. The review serves to identify the *analytical methods* appropriate for a study of visual complexity in the field of art. The present section also introduces *computational tools for modelling complexity* which are used in my art practice and in this project’s tests.

## Identifying Complexity

When we come across a system that is neither regular nor random – when it has a structure that is not easy to comprehend – then we call it ‘complex’. The most complex things we know are living beings. Indeed, life itself appears to be a special property of these most complex organic structures:

Life is a level of complexity that almost lies outside our vision; is so far beyond anything we have any means of understanding that we just think of it as a different class of object, a different class of matter... (Adams, 1998)

The same could be said of consciousness – of sensory capabilities and mental faculties – in terms of a Cartesian dualist philosophy: The complexity of mental phenomena seems so far removed from the material realm that we understand mind and matter as separate classes. To a complexity theorist, however, life and consciousness are regarded as *emergent* properties of complex systems, and the physical world does not simply divide along the lines of our limited understanding. Emergence is a crucial concept in complexity theory, and though it is difficult to define it can be summed up in the idea that *the whole is greater than the sum of its parts*. To take a basic example, the physical state of matter as solid, liquid or gas is an emergent collective property of a group of molecules. A single molecule of a substance cannot be said to be in any one state without reference to its relation to other molecules, and so the concept becomes redundant when a single molecule is considered in isolation. In terms of visual perception, we could say that the Gestalt grouping of picture elements into recognisable shapes or patterns is an emergent phenomenon. A perceived pattern emerges from the relationship of constituent elements, and cannot be found in the properties of the elements alone.

Often, emergent properties cannot be predicted, even when armed with complete knowledge of the constituent elements. For that reason, emergence can be understood as the *introduction of novelty* to a system; what emerges is something new, not present until the elements in the system interact. This *creative* aspect of complex systems is evidenced as much in the evolutionary history of life on earth as it is in the development of art. In this

sense, the artworld can be understood as a complex system – an idea which forms the subject of Niklas Luhmann’s *Art as a Social System* (2000). From the complexity-based theory of biologists Maturana and Varela (1980), Luhmann borrows the concept of *autopoiesis* (literally ‘self-making’) to describe the self-sustaining organisation of the artworld. The same concept also applies to the working model of the aesthetic outlined earlier, in which the artworld is represented as a system composed of many interacting feedback processes of art production and perception. Autopoiesis can be understood as another characteristic of complex systems; living things make themselves, whilst other complex systems sustain yet more systems and beget new properties. Of course, the idea can be applied to other social systems too (it has found currency in management theory, for example), and this demonstrates the transferability of knowledge from complexity science to fields such as art and aesthetics. In transferring ideas from complexity theory we should always take account of particular details, therefore, but we may also be forced to talk in more general terms or in terms of patterns at different levels of abstraction.

Some complexity theorists see their discipline as not just a part of traditional science, but as a new way of approaching scientific problems in general. For example, the title and contents of Wolfram’s *A New Kind of Science* (2002) reflect this aim. Others who share this view have described complexity theory in terms of Thomas Kuhn’s (1996) concept of a paradigm, that is, a shift in the beliefs that undergird the practice of science:

Complexity is emerging as a post-Newtonian paradigm for approaching from a unifying point of view a large body of phenomena occurring in systems constituted by several subunits, at the crossroads of physical, engineering, environmental, life and human sciences. (Nicolis and Rouvas-Nicolis, 2007)

What has changed in this new approach is the scientific view of complex systems, from being regarded as prohibitively problematic to being legitimate objects of scientific study. Now that computers offer a means of dealing quickly with large quantities of data, the way is open for an analysis of complexity in the many different fields in which it arises. Because it appears in so many different guises, there is no hard and fast definition of

complexity agreed upon by all – partly also because it is still an emerging field. At this stage, we have identified some of the characteristics of complexity, namely: interactivity, self-organisation, emergence and autopoiesis. While these are useful concepts in the theory of dynamic systems, they are less applicable to the aesthetics of static two-dimensional art. The gap between visual art and models of dynamic systems can be bridged with a computational approach, which is outlined in the following section.

### **Computational Complexity**

Complex systems are the kind of thing that science had struggled to cope with until the rise of computing, because they were just too complicated to be amenable to analysis. Digital computers enable the modelling of complex systems, and offer a way of dealing with problems that were previously intractable: “Part of the rise of the complex systems research agenda can be tied to the use of theoretical computation as a new way to explore such systems” (Nicolis & Rouvalis-Nicolis, 2007). In this context, computers are used less for their capacity to perform sophisticated calculations than for their ability to carry out a great number of operations in a very short time. Cellular automata, for example, are based on very simple operations, but what makes them difficult to compute is the sheer number of cells and their interactions. So for the study of complex systems, the computer is more of a labour-saving device than a particularly ‘clever’ machine. But the computer also provides a measure of complexity in terms of the amount of time or the number of operations that it takes to perform a task, and this is what is meant by ‘computational complexity’.

The computational approach to complexity is exemplified by the work of Stephen Wolfram, a scientist who gained a PhD on particle physics at the age of 20. Wolfram contributed to the field of complexity mainly through his work on cellular automata, which are computational models of complex systems. In 1986, he founded the first journal in the field – *Complex Systems*, but is a somewhat controversial figure in the scientific community partly because his recent method of disseminating findings does not conform to the usual

peer-reviewed publication system, choosing instead to self-publish funded by a successful software business. The two ventures are related, since Wolfram's *Mathematica* software was initially developed to aid his research into complex systems. *Mathematica* is used in the current project to generate images, analyse data and visualize the results.

Published in 2002, *A New Kind of Science* (NKS) presents Wolfram's 20-year investigation of complexity and computation. Its method is to exhaustively examine various types of simple programs, such as cellular automata, and to explore their behaviour over a range of complexity, thus providing a kind of natural history of the computational domain. NKS shows that different kinds of simple program exhibit the same range of behavioural patterns, and makes the claim that all computational systems above a certain threshold of complexity are essentially equivalent. Wolfram proposes that we can understand everything in the natural world as a computation, and that doing so allows us to apply what we learn from the study of simple programs to situations in real life. The current project is supported by Wolfram's work, since it uses his ideas about complexity to develop images for testing which are made with CA programs implemented in *Mathematica*. Because cellular automata play a significant part in the context and the content of the current project, we introduce them next.

## **Cellular Automata**

A cellular automaton is a system of 'cells' that evolve in discrete time steps according to a set of rules (Weisstein 2009). In the simplest possible CA, each cell can have two different 'states', and these can be represented by two colours: black for 'on' and white for 'off', for example. At each time step, every cell uses a set of rules to determine its next state, based on its current state and those of its neighbours. The set of rules has to include every potential configuration of states, but can often be described simply in words, for example: 'If both neighbouring cells share the same state, then remain in the same state; otherwise change state on the next step'. The simplest CA comprises a single row of cells – it is a one-dimensional CA. With states represented as colours, we would see cells change

state at each time step, but with a 1D CA, instead of watching a row of cells change colour over time, we could stack the rows in sequence, adding them successively below the last. In this way, we can visualise the evolution of a 1D CA over a portion of time in a single 2D image. This is what the rule specification looks like for the CA we described in words:



Figure 7 Visualization of the 1D CA rule ‘If neighbouring cells have different states, then change state on the next step’, rule number 150 of Wolfram’s elementary CA.

The rule as depicted above can be interpreted as follows: The top part (1 cell + 2 neighbours) specifies all potential current conditions of the cell, and the lower part specifies the resulting state. This rule is known as number 150 in Wolfram’s numbering scheme, derived from the rule’s unique pattern of cells in the lower half of the rule specification. Black cells are interpreted as ‘1’ and white as ‘0’ to give the binary number 10010110, which is 150 in decimal. Figure 8 shows how the rule evolves when starting with initial conditions of a row of white ‘off’ cells with a single black ‘on’ cell in the centre.

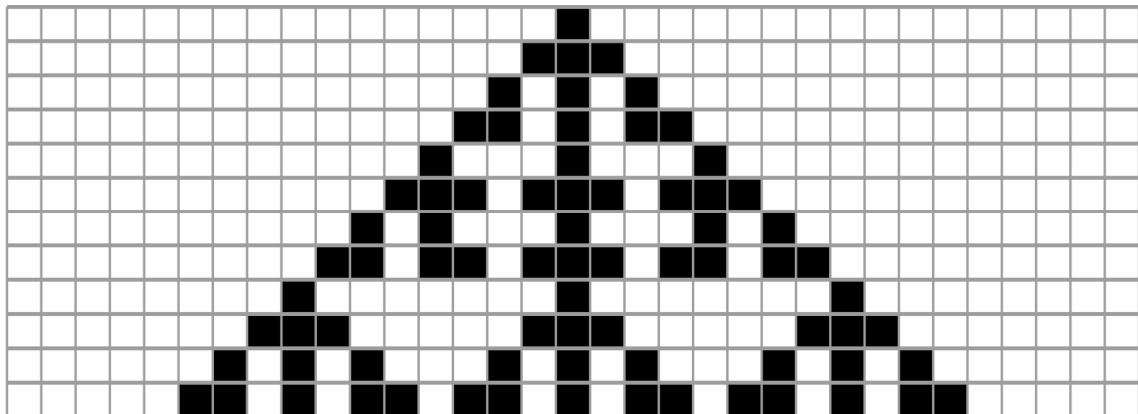

Figure 8 Evolution of elementary CA rule 150.

It is often impossible to predict the outcome (the type of pattern that will result) even when the rules are known and understood. This is because we are talking of an emergent property. Of the simplest 1D CA, with only two states and two neighbours taken into account, there are 256 different rules. Wolfram calls these the ‘elementary’ cellular



automata (eCA). Because they are relatively few in number, are simple to generate and understand, and because they display a wide range of complex behaviour/patterns, they make a good model for the science of complex systems. The fact that they are also easily visualized means that CA are ideal for use in the current investigation. Next we look at ways of mapping the variety of CA patterns that comprise a spectrum of visual complexity.

## Mapping Complexity

Wolfram (1984) mapped out four levels of complexity based on the visual appearance of patterns generated by cellular automata:

Class 1. Simple: homogeneous, no variation in structure.

Class 2. Periodic: simple sequences, regular or nested patterns

Class 3. Chaotic: aperiodic, irregular patterns.

Class 4. Complex: complicated localized structures, mixture of order and randomness.

These classes are represented in Figure 9. In the first image, the class 1 CA rule specifies that every possible configuration leads to a black cell, and the resulting image is completely black after a few steps. The class 2 CA image has a regular diagonal pattern, and repeats in a square tessellation. The class 3 image is a ‘non-repeating pattern’ with an overall texture but with chaotic variations on a small scale. The unpredictability of this rule (number 30 in the eCA) allows for its use in Wolfram’s *Mathematica* software as the basis of its random number generator. The last image shows complex structures within regular patterns, and is the only form of class 4 rule in the elementary CA.

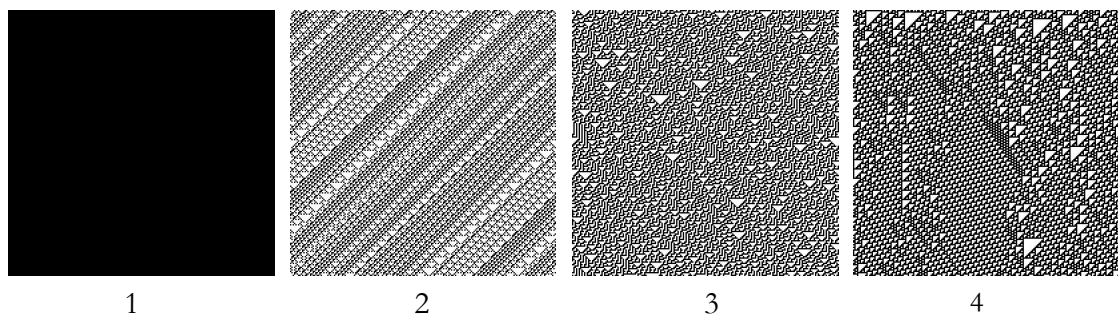

Figure 9 Examples of elementary cellular automata in Wolfram’s four classes of complexity.

Wolfram’s classification constitutes a qualitative analysis of complexity, in which the categories are not rigorously defined but are based on the perception of visual properties that reflect the structure and operation of CA. Li and Packard (1990) examine the distribution of eCA types in “rule space” (an abstraction of the possible forms that CA rules can take), and organise the same rules into five categories (A, B, C, D, and E). Their classification makes a distinction between two types of periodic (B, C) and chaotic (D, E) rule, where Wolfram has only one of each (classes 2 and 3), and places Wolfram’s class 4 rules into either a periodic or chaotic group depending on which aspect of the pattern is taken into consideration (which reflects the characterisation of class 4 eCA as having both order and randomness). Li and Packard’s scheme elaborates, rather than contradicts, Wolfram’s classification. For the purposes of the current investigation, Wolfram’s system is favourable, since it is based on visual properties, rather than the more mathematical scheme of Packard and Li. Wolfram also investigated the proportions of the four classes of complexity in various types of CA. The elementary CA contain approximately 50% class 1, and 25% each for classes 2 and 3. The results for CA with more colours and more neighbours are illustrated in Figure 10. It shows that random patterns are the most common in many of the CA types, and complex patterns are the rarest.

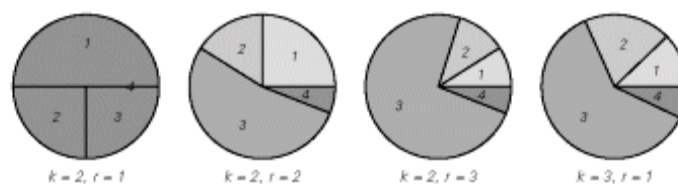

Figure 10 Proportions of complexity classes in various types of CA. Wolfram, 2002, p.948. ( $k$  = number of colours,  $r$  = number of neighbours on either side)

Christopher Langton’s Ph.D. thesis (1991) comprised a quantitative examination of the same patterns of behaviour in cellular automata by defining and manipulating a value he called the  $\lambda$  (lambda) parameter which measured the activity of the systems. As the value of the  $\lambda$  parameter was increased, Langton observed “a *phase transition* between highly *ordered* and highly *disordered* dynamics, analogous to the phase transition between the *solid* and *fluid*

states of matter” (1990 p.13, original emphasis). Increasing the lambda parameter is like turning up the temperature of a system, in which a substance changes from an ordered crystalline solid to a chaotic boiling liquid. The result is that “CAs exhibiting the most complex behaviour – both qualitatively and quantitatively – are found generically in the vicinity of this phase transition” (Langton, 1990 p.13). Langton coined a phrase to describe the location of these most complex structures – ‘the edge of chaos’. His results show that as the  $\lambda$  parameter is increased, the types of pattern encountered can be recognised from Wolfram’s classification, except that the sequence in which they appear is: 1, 2, 4, 3 (see Figure 11). The significant point is that the complex CA (class 4) are found between regions of order (classes 1 and 2) and disorder (class 3).

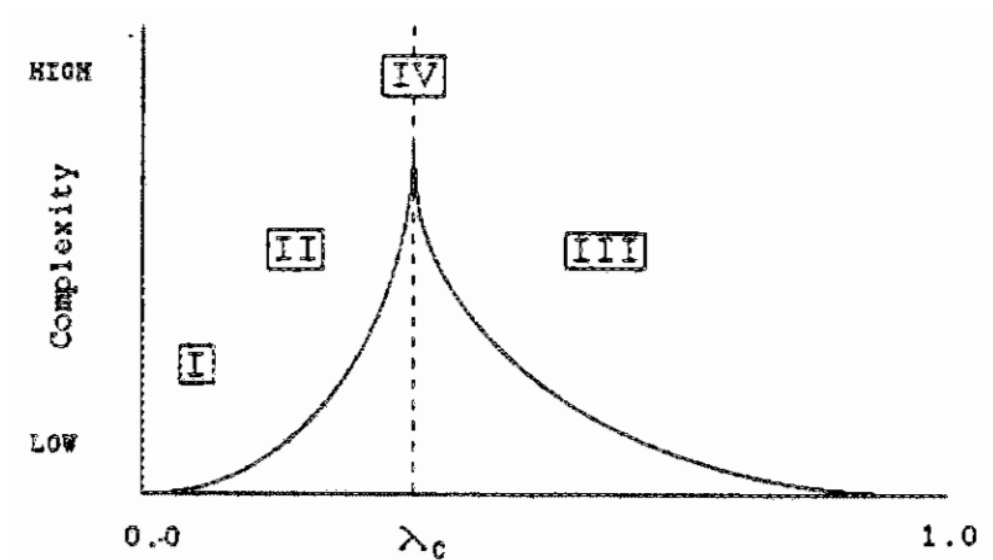

Figure 11 Location of the Wolfram classes in Langton’s lambda space. (Langton, 1990, p.32)

It is fair to describe the work of Wolfram, Li & Packard, and Langton as *mappings* of complexity, because they look at the entire spectrum of complexity and establish *what* is to be found *where*. This classificatory exercise is more than just taxonomy though, because Langton’s mapping is structured according to critical quantitative parameters of the programs. Cellular automata are particularly useful in this regard because their visual display allows us to use our sensory perception as a form of analysis (in other words, there appears to be a correspondence between their computational structure and their appearance).

Wolfram's qualitative mapping is thus augmented by Langton's quantitative measurement, and the location of different types of visual pattern is given meaning in the context of a measurable spectrum of complexity. The following sections examine the types of visual forms and patterns that are mapped out by classification systems of Wolfram and Langton.

### **Uniformity**

Uniform images are the simplest possible. They are not particularly interesting in themselves but they are important in establishing a base level for a measure of complexity. All uniform visual arrays are essentially identical in terms of structure – they may differ in colour (type of picture element), but the defining characteristic is that all the elements of a uniform class I image are identical; there is no differentiation of picture elements. Therefore, a description of this type of image can be quite short. We need to specify the colour of the elements just once, and the only other parameter that really makes a difference to analysis is the number of elements (the dimensions of the array). Altering the number of elements in a uniform image rarely alters it perceptually, however, since all the elements are identical. Thus a single-pixel image looks identical to a uniform image of the same physical size composed of many pixels. The idea that a description of a pattern can be shortened and simplified is central to the field of information theory. The following section discusses this concept in relation to class 2 patterns.

### **Order and Information**

In a paper that established the field of information theory, Claude Shannon (1948) measured information in 'bits' (binary digits), and defined information content in terms of order, or rather its complement, entropy. In physics, entropy is the disorder of a system; in information theory, the entropy of a message is inversely proportional to its predictability. Regular patterns can be predicted because they have order – they provide little new information, and so we can use a compact description of a highly ordered pattern in place of an element-by-element description of its content. Irregular patterns are hard to predict and describe, and so they have low order and high information content. This principle of

information theory provides the basis of data compression in digital image files (Salomon 2004). Those parts of a message that we can afford to discard in a short description are what is *redundant*. Regular patterns are redundant and can be compressed, whereas irregularity is less redundant and less compressible. The size of a compressed file thus reflects the amount of disorder or information content in the original data. This fact proves to be highly relevant to the current investigation, as it provides a basis for measuring the complexity of digital image files, and is taken up again in the following chapter's review of contextual theory and practices. Before we go further, it is worth noting some of the subtleties of order as understood in information theory.

The information-theory concept of order is not quite as intuitive as it may seem. Consider the two strings of digits  $\{0, 1, 2, 3, 4, 5, 6, 7, 8, 9\}$  and  $\{1, 0, 3, 2, 5, 4, 7, 6, 9, 8\}$ . Which is more ordered? We are likely to say the first one, but why? The second string is constructed from the first by swapping pairs of adjacent digits, so it is not *un*-structured – there is no randomness here. So why should it seem less ordered? Actually, it is a misleading situation, because in fact the two strings are structurally identical in terms of order. The confusion stems from the *meaning* we attach to the symbols used. The first string presents the digits in ascending sequence of their numerical value. But in information theory, we disregard the meaning of symbols and focus only on their quantity and variety. If we measure information by the length of a description, then each of those two strings take the same amount of description (for each we must specify ten symbols and ten locations), and are thus equal in terms of order and information. If we had used ten meaningless symbols in place of Arabic numerals, we would be unable to perceive any difference in order between the two strings. Order enters the frame only when there are multiples of things to be ordered (strictly speaking, when there are more possible positions than there are types of element). Thus, for example  $\{0, 1, 0, 1, 0, 1, 0, 1, 0, 1\}$  is more ordered than  $\{0, 0, 0, 1, 0, 1, 1, 0, 0, 1\}$  because we can form a more compact description of the first string ( $\{0, 1\} \times 5$ ). In the same way that information theory disregards the

meaning of elements in the measurement of information, the current project disregards the meaning and interpretation of images, and focuses only on the objective formal properties of visual complexity and their subjective aesthetic perception.

## Fractals

Besides simple repetitive patterns such as stripes and checks, Wolfram's class 2 CA images include another type of ordered image, in which pattern repetitions are nested within themselves. These intricate self-repeating patterns are called fractals, and are exemplified by the Mandelbrot set (Figure 12).

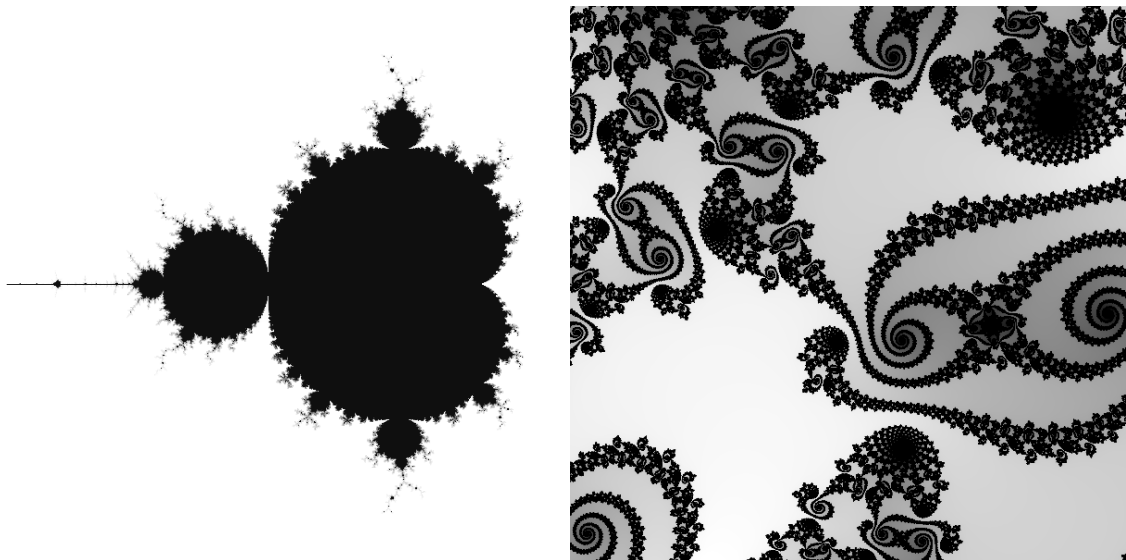

Figure 12 The Mandelbrot set, overview (left) and detail (right). The extraordinary variety of patterns in its infinitely complicated boundary reflects the fact that it is a superset of many fractals, where each point in the set represents a unique fractal pattern called a Julia set.

Benoit Mandelbrot brought the geometry of these wiggly, grainy and wrinkled forms to the field of mathematics, demonstrating how they can be methodically generated and precisely measured. The value of this new geometry was that it applied to many of the forms we see in nature, which are poorly modelled by the more familiar and regular mathematical constructs: “Clouds are not spheres, mountains are not cones, coastlines are not circles, and bark is not smooth, nor does lightning travel in a straight line” (Mandelbrot, 1982, p.1). The computational study of fractal geometry makes possible the

analysis of forms that used to be viewed as ‘pathologically’ problematic but which are common in nature. Traditional Euclidean geometry cannot cope with such ‘rough’ forms:

...the language of mathematics and its characters are triangles, circles and other geometric figures, without which one wanders about in a dark labyrinth. [...] But they have turned out not to be sufficient, “merely” because most of the world is of infinitely great roughness and complexity. (Mandelbrot, 2004b)

Mandelbrot cites Katsushika Hokusai’s famous print *The Great Wave off Kanagawa* (Figure 4) as one of the earliest visualizations of fractals: “Hokusai holds a central role in my current view of fractals as a notion familiar to Man, in one form or another, since time immemorial” (2004b, p.26). Whereas artificial fractals repeat their pattern regularly, natural fractals tend to be more irregular. The Mandelbrot set (Figure 12) is irregular in this sense, which may explain why this pattern has been widely reproduced beyond the mathematical domain from which it came. Because of the property of self-similarity, it can be difficult to judge the scale of fractals (in the absence of a visual cue) because they look similar whether nearby or far away. For this reason, the image of fractal tree branches in Figure 3, which was taken from a distance of around 12 feet, can also be perceived as a view of the earth seen from a great height, like a satellite image of mountains and rivers. These two alternative visual interpretations are possible because both are characteristically fractal in form. Because fractals have a similar structure at all levels, they are fairly simple, and so a description of them need only be fairly short. Indeed, the Mandelbrot set is constructed from a surprisingly short algorithm:  $z_{n+1} = z_n^2 + C$ . The intricacy of a fractal image such as this comes from the depth of iteration of the algorithm (see Figure 2, in which progressive stages of iteration are illustrated). Fractals may thus have great depth of detail – which in theory is infinite, but in practice is limited by physical constraints – but because fractals have only one type of pattern at all levels, they are essentially quite simple. Unlike the many different patterns in an oil painting described in the introduction, magnifying part of a fractal reveals no new information, but the same pattern repeated at smaller scales.

## Chaos and Randomness

Chaos theory began in the 1960s when the meteorologist Edward Lorenz used computers to model the weather (Gleick, 1993). When Lorenz resumed a weather simulation from halfway, the digits he entered for the system's variables had unknowingly been rounded off, and so the conditions were slightly different from those when it had been stopped. This went unnoticed until the system began to diverge from the previous run until it no longer resembled the earlier weather model. Lorenz understood its significance for complex systems: small differences can dramatically alter the behaviour of a chaotic system, so modelling such a system will always be uncertain. Lorenz's contribution has become known as the 'butterfly effect'. It demonstrates that systems such as the weather are sensitive to initial conditions, and this is a characteristic of chaos.

The butterfly effect is a common expression for the sensitivity of chaotic systems, an old idea which is embodied in the rhyme that begins, "For the want of a nail, the shoe was lost". The problem with this expression is that it only stresses one aspect of chaos: while it is true that tiny events can have large consequences, there are many such small and large events happening all the time. Most of these perturbations do have long-term effects on the state of the system, but thankfully not every butterfly causes a tornado! What is most important in the idea of the butterfly effect is the instability and unpredictability of the system, for these are the characteristics of chaos. Instability is a property of dynamic systems, and so this is not applicable to the formal properties of images, whereas unpredictability *can* be applied to images by using the information theory concept of order. Information theory treats this visual information as a streamed message in which the elements are specified one after another. Regular patterns in the data stream are predictable, which makes them redundant, and so they can be compressed (a shorter description will suffice). Conversely, irregular patterns are unpredictable, so they have less redundancy, and are less compressible.



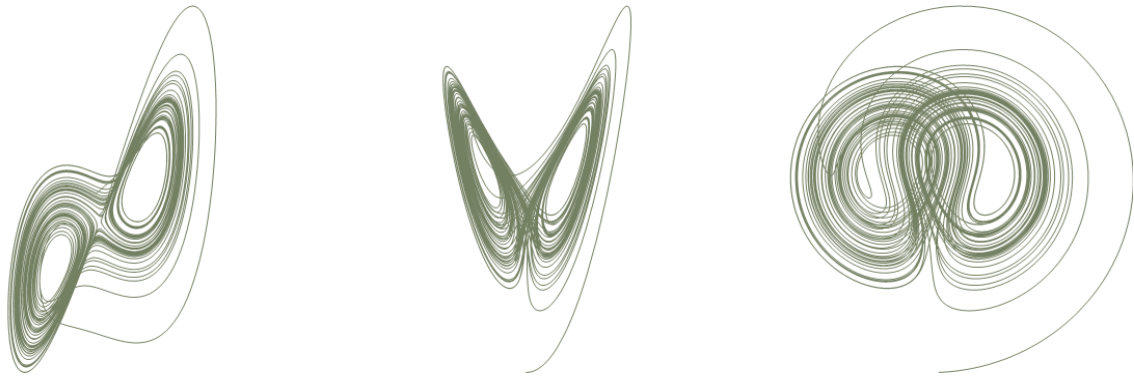

Figure 13 The Lorenz attractor (top, front and side views).

Lorenz modelled the evolution of simplified weather systems by reducing the number of variables. The Lorenz attractor (Figure 13) represents the changing state of a three-variable system by plotting its co-varying values in three dimensions. The shape described by this path in “phase space” is fractal, and so it comes under the category of strange attractors. What this means is that the system does not settle down to a steady state (which would describe a single point in phase space) as in class 1 systems, or a periodic state (a loop) as in class 2, but that it is constantly and unpredictably changing. A chaotic system is not random, because it follows definite rules or laws (weather obeys the laws of physics, for example), but the results may be indistinguishable from randomness. In a book that brought this science to the wider public, James Gleick characterised chaos as “order masquerading as randomness” (1993, p. 20). Upon reading Gleick’s *Chaos* (1993), I tried out for myself an example described in the book: I dropped a leaf into a stream, and watched its meandering path downstream. Additional leaves dropped in the same place followed a similar path to start with, but gradually diverged until they no longer resembled the first. This is in effect a repetition of Lorenz’s experiment, which demonstrates the sensitivity to initial conditions of a chaotic system; immeasurably or imperceptibly small differences in initial conditions get magnified by the system and lead to unpredictability.

Randomness is also characterised by unpredictability from one moment to the next, but it is expected to be more predictable than chaos overall: A truly random string of numbers contains equal proportions of each digit. In that sense, randomness is predictable

and ‘smooth’, whereas chaos is ‘lumpy’. Randomness means that there is no pattern from one element to the next, but it conforms to statistical regularity overall, just as a fair coin toss converges to 50 percent ‘heads’ over time. Similarly, the heights of a randomly selected population can be expected to conform to a normal distribution (a bell-shaped curve). It is sometimes thought that humans are unable to generate truly random number sequences, but there is evidence to the contrary (Persaud, 2005). Because randomness by definition has no regularity, a random arrangement contains a maximum of information content, lacks redundancy, and cannot be compressed.

### Complexity

The types of computer-generated pattern that Wolfram classified can also be found in nature. After Wolfram published his results, he received many such examples sent to him by the public, the most common of which was a particular type of sea snail shell. The textile cone shell bears a striking resemblance to some of the CA patterns, with the same kind of triangle structures seen in eCA rule number 22 (Figure 14). Wolfram (2002) suggests that the shell’s colouration derives from an analogue of the CA rule in the interaction of chemical pigments as the snail shell grows along its edge.

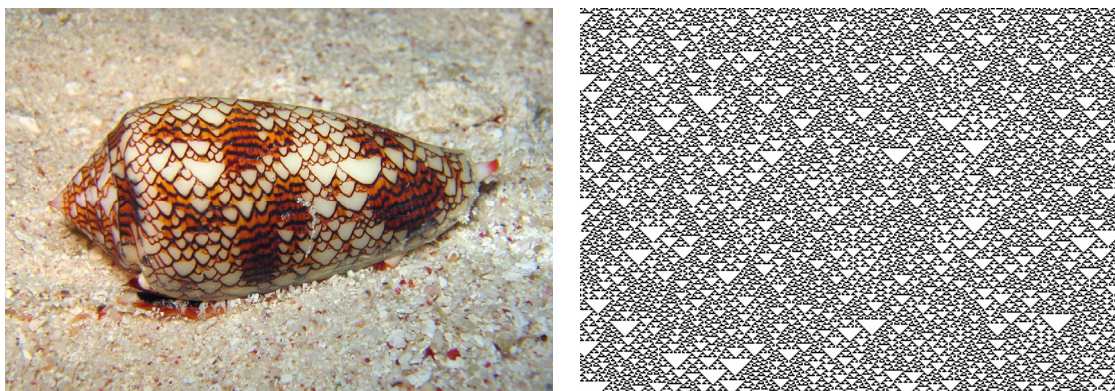

Figure 14 Textile cone shell (*Textile conus*) and rule 22 elementary cellular automata.

The example of the cone shell displays an irregular pattern of the class 3 type. Like the description of randomness earlier, this pattern has local disorder (irregular arrangement and size of elements) and global order (similar overall texture). Of the 256 elementary cellular automata, Wolfram identifies only one of the 256 elementary CA as complex (class

4). This rule (number 110) is illustrated in Figure 15. It is plain to see that rule 110 has a mixture of class 2 regularities and class 3 randomness, which by Wolfram's definition makes it a class 4 pattern. By the information theory measure of entropy, the rule 110 pattern is mid way between order and randomness. The image also has the greatest number of different types of pattern of all the elementary CAs, which makes it the most complex in terms of the difficulty or size of its description. If we think about the types of two-dimensional artwork in galleries, we can probably find examples to fit each of the four classes of complexity, but I suggest that the majority could fairly be described as containing elements of both order and chaos. This project aims to measure the complexity of a range of artwork to see just how complex it is in relation to the classes of pattern we have identified. Measuring visual complexity allows us to investigate its relation to the aesthetic perception of art. The next section looks at some of these measures.

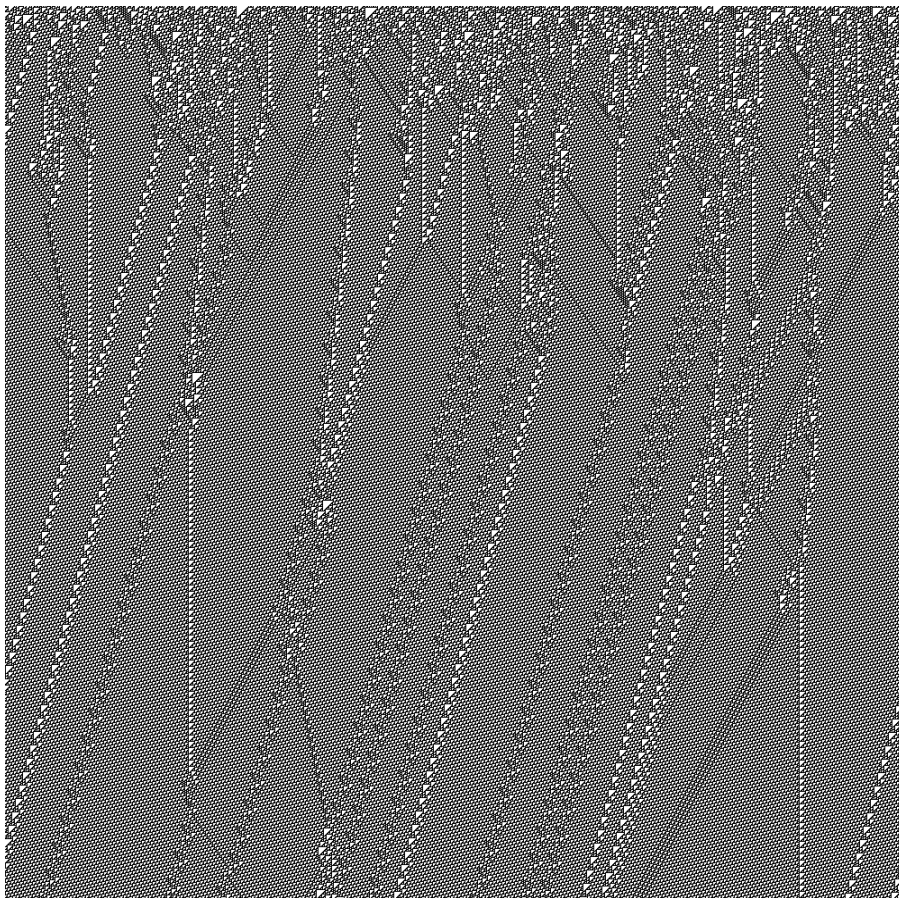

Figure 15 Elementary CA rule 110. This image shows a thousand cells (width) evolving over a thousand time steps (downwards), a total of 1 million cells/pixels.

## Measuring Complexity

To be measurable, a thing must be quantifiable, but what exactly do we quantify when it comes to complexity? Langton (1990) not only made a qualitative mapping of complexity in cellular automata, but also measured complexity by quantifying the ‘activity’ of each rule (the lambda parameter). An alternative proposal is to measure complexity by quantifying difficulty:

The meaning of this quantity should be very close to certain measures of difficulty concerning the object or the system in question: the difficulty of constructing an object, the difficulty of describing a system, the difficulty of reaching a goal, the difficulty of performing a task, and so on. (Li 1991 p.381)

From this selection, we can see that measures based on the difficulty of making and describing are applicable to art objects. Prominent examples of measures based on difficulty-of-description include: information, entropy, algorithmic complexity, and minimum description length (Flake 1990; Wolfram 2002). There is no single measure of complexity accepted in all areas of complexity science, but amongst the most common is a measure of the ‘difficulty-of-description’ type developed independently by Solomonoff (1964), Kolmogorov (1965) and Chaitin (1966). It is related to Shannon’s (1948) measure of information, and is defined as the length of the shortest algorithm that generates a given pattern of data (Flake, 1990). In the field of complex systems, the measure is called Kolmogorov complexity, or algorithmic information complexity (AIC). A simple pattern requires only a short algorithm to reproduce it, whereas a more complex pattern requires a larger one, hence the algorithm’s size is a measure of the pattern’s complexity.

Murray Gell-Mann, co-founder of the Santa Fe Institute for research in complex systems, describes AIC as a “crude” measure of complexity because it does not entirely agree with intuitive notions of complexity (2004, p.34). At the top of the AIC scale are structures that cannot be compressed, which have no regularities and which are therefore random. The problem is that randomness is not the same as complexity, which is generally

understood to involve a meaningful (non-random) relation of structural elements, as Gell-Mann points out:

This property of AIC, which leads to its being called, on occasion, “algorithmic randomness”, reveals the unsuitability of the quantity as a measure of complexity, since the works of Shakespeare have a lower AIC than random gibberish of the same length that would typically be typed by the proverbial roomful of monkeys. (Gell-Mann, 1995, p.16)

Gell-Mann (2004) proposes a refinement of this crude measure, which he calls ‘effective complexity’ (EC). EC is almost the same as AIC, except that it is based on the shortest description of the *regularities* in a system. With both measures, a uniform structure is rated lowest since it has the least information and maximum redundancy. A random structure has maximum information, but no regularities (patterns), and thus rates low in terms of EC, instead of being rated highest by AIC. A complex structure with lots of different patterns will require a larger description, and so it would be rated high in EC, in accordance with our intuition. Figure 16 illustrates the relationship between the two measures. The similarity to Langton’s map of complexity (Figure 11) implies the similarity of the lambda parameter scale to an information-based measure of complexity such as AIC.

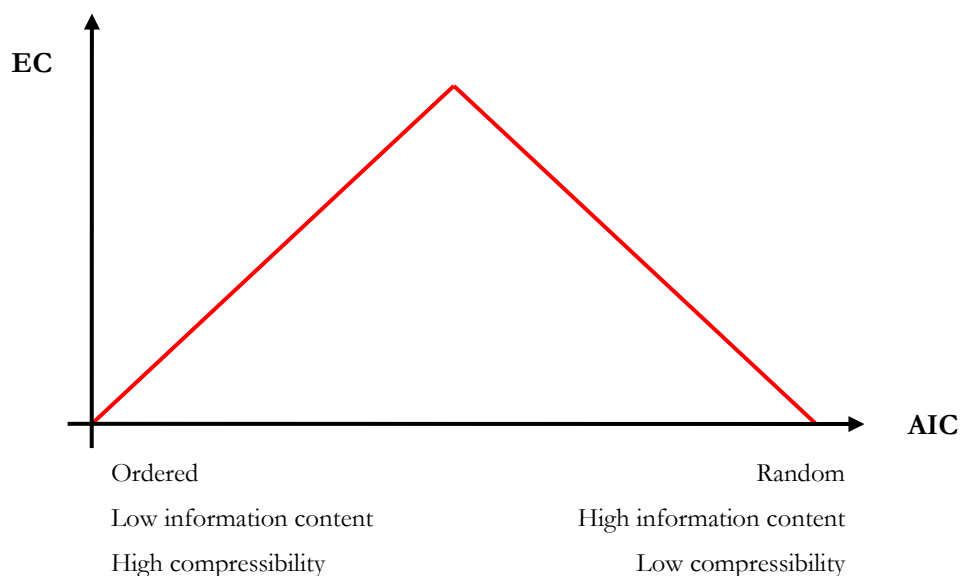

Figure 16 Effective complexity and algorithmic information complexity. Adapted from Flake (1990) p.135 and Gell-Mann (2004) p.59.

Technically, AIC is incomputable because we can never be certain that we have found the shortest algorithm. Nevertheless, it can be closely approximated with a complexity measure known as minimum description length (MDL), which provides a practicable equivalent to AIC. The MDL measure can be implemented with the information theory method of data compression, which reduces data to its smallest amount by removing redundancy. Thus data compression gives us a measure of complexity based on difficulty-of-description, which in this case is quantified by the length of the shortest description.

The difference between information-based (AIC, lambda parameter) and intuitive (EC, Wolfram's classification) measures is significant to the current project because it encapsulates the objective-subjective duality of complexity and highlights the potential difficulties in measuring and understanding complexity in terms of aesthetic perception. Nonetheless, there are suggestions of a similarity between human perception and computational measures of aesthetic complexity: Wolfram (2002, p.559) says that

...by far the most common way in which we determine levels of complexity is by using our eyes and our powers of visual perception. So in practice what we most often mean when we say that something seems complex is that the particular processes that are involved in human visual perception have failed to extract a short description.

### **Measuring Visual Complexity**

The early stages of this research project located the majority of publications on visual complexity in the sciences of perception, rather than in aesthetics or the science of complex systems. Amongst the many different methods of measuring visual complexity, one stood out from the others since it seemed the most straightforward and compatible with images of artworks. Don C. Dondori (2006a) finds a correlation between subjective estimations of visual complexity and the size of compressed digital image files. Dondori's method began with research conducted for the Canadian Ministry of Defence, which measured the difficulty of reading naval charts and radar images in order to determine the optimal information density of visual displays. Dondori quantified the complexity of images

based on their information content by measuring the size of compressed image files. The subjective complexity of the visual displays was measured by magnitude estimation scaling (MES), a psychological technique in which participants report a quantitative estimate of their perceptions. The results show a strong correlation (0.78,  $p < 0.001$ ) between subjective complexity ratings and the logarithm of compressed file sizes. We now know that data compression is a form of the MDL measure of complexity, which is equivalent to AIC. Donderi's finding supports the notion of an information-based measure of visual complexity and suggests that it may work for images of art as well as the simpler graphic displays in those experiments.

Donderi's methods for measuring objective complexity by file compression and subjective complexity by MES may be suitable for the current investigation. However, we have seen that these information-based measures rate randomness the highest, and that what we understand as complexity is actually somewhere in between order and randomness. The first implication is that Donderi's experiments examined only the lower range of visual complexity, a point acknowledged by Donderi & McFadden (2005 p.78). It also implies that the correlation between subjective and objective complexity may break down for the most information-dense (random) images, in the same way that the correspondence between AIC and EC diverges with increasing randomness (Figure 16).

Donderi (2006b, pp.87–88) makes the link with Wolfram's statement of the issue (2002, p.559) in terms of a 'threshold of perception': We fail to perceive the inherent patterns (which can be revealed by mathematical analysis) in some chaotic images such as class 3 CA images, and so they appear random because they are beyond our threshold of perception. The peak of the graph in Figure 16 represents this perceptual threshold, beyond which our perception of complexity diverges from information-based measures. The suggestion is that the correlation between objective complexity (AIC) and subjective complexity (MES) will diverge for the most complex/random images. Empirical evidence for this hypothesis of a perceptual threshold is yet to be seen. Thus we have identified a

gap in knowledge of visual complexity which has the potential to contribute to understanding its role in the aesthetics of visual art. Being able to determine the performance of Donderi's file-size measure over a wider range of complexity – mapping the perceptual correlation with informational complexity – also provides a firm footing for the investigation into the perception of complexity in art and design artefacts because it maps the region of the spectrum of complexity that these artefacts are assumed to occupy.

## Project Outline

The focus of this project is on the aesthetic properties of visual complexity in art and design. The hypothesis is that visual complexity sustains interest and contributes to aesthetic value by affording grounds for visual exploration (pattern-finding). The aim is to understand the relationship between objective properties of images with the subjective properties of perception. The objective is to find a method of measuring the visual complexity of contemporary art and design in order to contribute to this understanding. The philosophy of aesthetics helps us to understand the practice and perception of visual art. With knowledge of complexity from systems theory and order from information theory, we have a collection of tools that we can use to approach the subject of visual complexity. The computational approach to visual complexity necessitates a quantitative formulation of aesthetic properties which at first may seem alien to the more qualitative studies undertaken in the tradition of philosophical aesthetics, but importantly it allows for the measurement of aesthetic properties and empirical investigation.

In summary, the focus of the research is as follows:

*Focal theory:* Why is visual complexity interesting? Why are good artworks often visually complex? What is the relationship between visual complexity and aesthetic value?

*Contextual theory:* What is visual complexity? How do we perceive it? Where is visual complexity in art and design? Where is contemporary aesthetic discourse?



*Data theory:* How can we measure visual complexity? How can we measure aesthetic perception? Do the measures work with the whole range of complexity, including images from art and design?

*Contribution:* What is the relationship between objective and subjective visual complexity? Does art training affect perception of and preference for complexity? How does the complexity of an image relate to preference and quality?

## **Planned Contribution to Knowledge**

This research project aims to make a contribution to knowledge initially by mapping aesthetic discourse across the domains of art, philosophy and science. The literature review presents a structured critique of theory and practice relating to the aesthetics and science of visual complexity. Its aim is to collate a novel review of relevant material that is unrestricted by a disciplinary focus, insofar as it goes beyond the range of material written by and for art practitioners to include foundational texts and current papers from experimental psychology, computer science and complex systems theory. The purpose of this review is to establish a map of current knowledge in order to identify the gaps to which this project can contribute and to identify the methods by which this knowledge can be created.

The principal contribution to knowledge is made by extending empirical research methods to the field of art and design. Techniques from experimental psychology and computer science are applied to material from contemporary creative practices. The aim is to add to knowledge by testing these methods with novel material and to extend the range of material, specifically in terms of the range of visual complexity, to assess the performance of visual complexity measures. One of the objectives is to investigate a wide range of complexity to test the hypothesis that there is a perceptual threshold of complexity, and to determine whether an information-based measure will support the hypothesis, as predicted by Donderi (2006b). Examining a wide range of visual complexity

by using cellular automata images allows for a mapping that can be compared with the findings of Wolfram and Langton. Using the method of MES with these images then allows for the results to be correlated with the subjective aesthetic response. This provides a connection between findings in complexity theory and empirical psychology, and establishes a base for further investigations on visual material from contemporary visual art practices.

In addition to the empirical investigation of visual complexity, this project draws on art practice to explore novel methods of creating artwork. Creative practice plays a role in exploring the aesthetics of visual complexity from the artist's point of view, but also provides a source of visual material for use as stimuli in the empirical tests. The tests offer a novel method of evaluating this artwork, allowing for precise quantitative measurement which is complemented by the qualitative data gathered in interviews with test participants. Together, the creative and empirical work make for a balanced analysis of the aesthetics of visual complexity by investigating both objective and subjective aspects of the topic, and by considering both the production and the perception of visual art.

# Chapter 2

## Mapping Theory and Practice

### Introduction

The aim of this chapter is to support the development of the research through an exposition of the historical, theoretical and practical contributions to the field of aesthetics. In keeping with the trans-disciplinary methodology of the project, this contextual review covers the various manifestations of aesthetics as it appears in the domains of art, philosophy and science. The material centres on the aesthetics of visual perception and visual art, which together define the context of the study. Within this context, the critical review examines ways of understanding, realizing, and analysing visual complexity. Evaluating these practices provides a basis for selecting the appropriate research methods. The aim is to map contemporary aesthetic discourse and situate the project within the field, in order to define its contribution to knowledge and its engagement with current practice.

The structure of this review is designed to progress from the general foundation of aesthetics and complexity discussed in the previous chapter to the more specific questions concerning visual complexity which are at the core of this project. In trying to provide a solid grounding for the research, this overview of contemporary aesthetic discourse takes us from its philosophy, through scientific investigations, to artistic engagement. The sections are arranged in order from the theoretical pursuit of the aesthetic, to the practical analysis of visual complexity, and finally the creative application of aesthetics. This structure aims to present the relevant issues in an order which will allow for a coherent development of the thesis. Accordingly, it involves a narrowing of focus towards the issues surrounding the aesthetic perception of visual complexity in two-dimensional art and design.

# Aesthetic Theory

The previous chapter introduced some of the concepts central to aesthetic discourse. It brought us up to the point where the main concern of the field was to identify the essential features of art and the aesthetic that allow for philosophical definitions in terms of necessary and sufficient conditions. For the purposes of this project, the division between aesthetics then and now is marked by the influence of Wittgenstein. The new line of aesthetic thought developed in what has been called ‘analytic’ philosophy – a generally Anglo-American discourse in the Kantian tradition, contrasted with the ‘continental’ philosophy of central Europe. As described by Noël Carroll,

The purpose of the analytic philosophy of art is to explore the concepts that make creating and thinking about art possible. Some of these concepts include: the very concept of art itself, as well as the concepts of representation, expression, artistic form, and aesthetics. (1995, p.5)

This thesis follows the analytical tradition of aesthetic philosophy. In part, this is a pragmatic decision, because the continental philosophies are of less utility for this project. More significantly, the continental attachment to post-modern scepticism of scientific method is incompatible with the methodology adopted in this project. A more detailed examination of this issue is presented in the methodological discussion in Chapter 3.

From the preliminary discussion in the previous chapter, we have identified the central concerns of aesthetics as perceptions, properties and practices. Each of these concerns has both objective and subjective aspects which apply in varying degrees to the natural and/or artificial. Jerrold Levinson (2003) identifies three foci of aesthetics: art, aesthetic properties and aesthetic experiences. Yet the aesthetic properties Levinson lists, such as beauty, ugliness, and sublimity, are in fact indistinguishable from aesthetic experiences; we certainly attribute them *to* objects, but that doesn’t mean that they are intrinsic properties *of* the objects. As such, these attributes may be described as subjective aesthetic properties (in the sense that they are personal and variable) as plausibly as they

may be called objective properties. Therefore, the way in which we structure the field depends on how we negotiate the objective-subjective duality of aesthetics. Instead of getting embroiled in the finer points of this distinction, my stance is to accept the duality of aesthetic experiences and to regard the aesthetic as the interaction between object and subject. This position is represented in the working model of aesthetics, which identifies the aesthetic with these interactions.

## Perceptual Aesthetics

Philosophical aesthetics can be divided into the study of art and the study of perception. The former pertains to questions about art objects: how we recognise them as art, why we find them pleasing, and how they should be evaluated. The other side of aesthetics concerns the phenomena that comprise aesthetic experiences, which include natural forms and scenes as well as human-made things. A proponent of perceptual aesthetics of art is Monroe Beardsley, who classifies an artwork as “an arrangement of conditions intended to be capable of affording an experience with marked aesthetic character” (1982, p.299). For Beardsley, aesthetic objects are a subset of perceptual objects, “some of whose qualities, at least, are open to direct sensory awareness” (1982, p. 31).

A key notion in perceptual aesthetics is experience. In Beardsley’s philosophy aesthetic experiences have value when they fulfil at least one of three primary aesthetic criteria: unity, intensity and complexity. Artworks are good if they afford these aesthetic experiences. Richard Lind suggests that perceptual interest should be distinguished from theoretical interest, because “while the latter is an inquisitiveness about *hidden* organization, the former is a curiosity about *manifest* organization.” (1995, p.120). It is this kind of manifest organisation of visual art and design that is under investigation in this project. The hypothesis that visual complexity sustains interest is supported by Lind’s description of aesthetic value in terms of perceptual interest:

Satisfying perceptual interest is a cognitive skill; infants spend hours perceptually “making sense” of simple objects. The perceptual skills of adults are so well honed, however, that we hardly ever notice we are habitually satisfying this goal-oriented interest. Only when an unusual arrangement defies instantaneous clarification do we find ourselves consciously interested in making sense of it, as when, for instance, we are confronted for the first time with the non-objective complexity of a Jackson Pollock. (Lind, 1995, p.120)

Lind claims that this formulation solves several of the traditional problems of philosophical aesthetics. One of these is the problem of the disinterested attitude which, since Kant, has often been maintained as an essential aspect of aesthetic perception because it helps to mark the distinction from non-aesthetic interest. Lind dispenses with disinterest as a necessary feature of aesthetic judgement, replacing it with an interest in the act of perception itself. The fact that Lind describes this aesthetic interest as a “cognitive skill” suggests that it is something that can be learned. We might assume that the teaching of this kind of skill is to be found in art and design schools, if anywhere, but can it actually be taught or is it something that is only implicitly developed in an artistic education? This question is beyond the scope of the present investigation, although it is possible to explore its implications: If aesthetic perception is a skill, and not merely a given sub-personal mechanism, then regardless of how it is learned we might expect to find differences in perception between people who have undergone an education at art school and those who have not. The tests in this project investigate the difference in aesthetic perception between two groups – those who practice art and design and have received an art education, and those who have not.

### **Environmental Aesthetics and Affordances**

The way in which a skill is acquired depends on the learning environment, which includes environmental conditions as well as the social and cultural context. Since perception in humans predates the culture of art, the environment plays a large part in shaping our perception through the evolution of perceptual mechanisms. Thus we are perceptually sensitive to the environment in which we have evolved, and we can

understand more about aesthetic perception by looking at how we perceive the environment. This approach can be called ‘environmental aesthetics’.

An example of this kind of understanding is *The Ecological Approach to Visual Perception* (1986) by J.J. Gibson, which describes our relation to the perceptual environment in terms of “affordances”. According to Gibson the purpose of perception is action, and since the need for action varies from time to time, the affordances to be acted upon also vary. Gibson pictured the entire visual world as a dynamic visual array. He described a perceiver whose moving eyes passively “pick up” a stream of visual information from the array. The invariants in the stream signify stable objects and the flux signifies movement or change, either of the observer or the environment. Visual systems tend to be ‘tuned’ to recognise or respond to the perceptible properties of affordances. This explains why we tend to like pictures of natural scenes with wide open spaces and clumped trees with a source of running water; such environments afford food and shelter, with a good vantage point to spot both predators and prey. Constable’s *The Hay Wain* (1821) falls into this category of images – at least it does so for Westerners, with its North-European landscape. Other cultures have preferences for their own familiar terrain, but we all share the same basic understanding of the affordances of the environment and have inherited the same perceptual mechanisms. In addition, we all share a similar ability to perceive affordances, not just in natural environments but also in designed artefacts.

Gibson’s ecological theory (1971; 1978) of passive ‘pick-up’ of visual information challenges the conventional view that perception involves representation and interpretation. As such, Gibson’s view represents a minority amongst psychological theories of perception (Bruce, Green and Georgeson 2003, p.80). As a perceptual theory, Gibson’s method stands outside the psychological consensus because it is non-empirical, but it is also at odds with art discourse: During the 1970s, Ernst Gombrich developed an argument with Gibson in *Leonardo*, the journal of art, science and technology. Gombrich’s contribution to psychological discourse on perception is presented in *Art and Illusion*

(1977), which draws on the conventional psychological theories that Gibson rejects. Nevertheless, Gombrich described Gibson's *Perception of the Visual World* (1950) as "exciting", and he recognised that "psychology has come alive to the immense complexity of the processes of perception, and no one claims to understand them completely" (1977, p.21).

Despite the arguments against Gibson's approach to aesthetics from art and psychology, the concept of affordances retains currency in the discourse of design. In the context of visual display design, Donderi (2006b, p.81) interprets Gibson's affordances as "visual information that allows the perceiver to act" which are "in the visual information stream whether or not the observer acts on them." Graphic design and product design can take advantage of our ability to perceive affordances by using visual cues which allow the user to interact with a designed artefact. The idea of designing an artefact that can be used in this way is embodied in one of Dieter Rams' design principles: "good design makes a product understandable" (Design Museum, 2007). The psychologist Don Norman introduced Gibson's concept of affordances to the field of design in *The Psychology of Everyday Things* (1988), later published as *The Design of Everyday Things* (1998). Norman says that the concept "has caught on, but not always with true understanding", and admits that some of the blame lies with himself for failing to stress the point that affordances are those that are *perceived*, and not just those properties that are inherent in a physical artefact. For that reason, Norman suggests that 'perceived affordances' might have been a more accurate phrase to use, because

...in design, we care much more about what the user perceives than what is actually true. What the designer cares about is whether the user perceives that some action is possible (or in the case of perceived non-affordances, not possible). (Norman 2009).

The application of these principles is particularly relevant to interface design in human-computer interaction (HCI). Besides the distinction of real and perceived affordances, Norman is also careful to distinguish between affordances and cultural



conventions. An example of a cultural convention in HCI is the scroll bar, which nowadays is generally moved in one direction to make the text on screen scroll in the opposite direction. Norman suggests that good design should follow cultural conventions, but what is most important in usable products is that the desired controls should be perceived so that the desired actions can be discovered. This understanding of affordances is also applicable to interactive art, in which the audience has some control over the appearance or behaviour of the artwork. Indeed, the manipulation of perceivable controls and their actions may be a focal point for the interactive artist, who is freer to play with affordances and the expectations of the audience than is the designer of marketable products. On the other hand, the emerging field of critical design (the term coined by Dunne 1999) is less constrained by market forces and company briefs and thus, like art, it is able to exploit the perception of affordances in the creation of challenging artefacts and situations.

## **Aesthetic Theories of Art**

Except for the kind of interactive art mentioned above, looking at art does not usually require ‘action’ of the sort Gibson described, and so the ecological theory of affordances is not wholly applicable to the aesthetics of art. The aesthetic theory of art focuses on a very particular aspect of the human environment, but what it shares with the ecological theory is a grounding in perception. We discussed in the previous chapter the division of aesthetics into the study of perception and the study of art. Aesthetic theories of art are those that tie together these two different aspects and enable a definition of art in terms of perception:

...the aesthetic definition of art puts one in a position to say why art is valuable. Art is valuable because it affords aesthetic experience. Thus if we can say why having aesthetic experiences are valuable, then we are also on our way to saying why art is valuable. The value of art will be derived from the value of having aesthetic experiences. (Carroll, 1995, p.167)

We also discussed previously the move away from objective properties to subjective properties of perception, and noted that the definition of art – a traditional aspect of

aesthetics – has also shifted in this direction. The following section examines this shift in more detail.

### **The Open Concept of Art**

Although Wittgenstein had considered aesthetic matters in some of his writings, his influence on philosophical aesthetics is indirect since it stems from interpretations of his more general philosophy. Of his writings on aesthetics, one notable remark is that “The subject is both very big and entirely misunderstood as I see it.” (Wittgenstein 1966). The idea that influenced the course of aesthetics comes from the publication in 1953 of *Philosophical Investigations* (Wittgenstein 2001) on language and knowledge, and it is summarised as follows:

The idea that in order to get clear about the meaning of a general term one had to find the common element in all its applications has shackled philosophical investigation.  
(Wittgenstein 1972, p.19)

Wittgenstein was referring to the philosophical practice of forming ‘closed’ concepts based on common elements or essences. ‘Game’ is an open concept because there are no essential features shared by all the things we know as games (football, chess, computer games, hide-and-seek), and yet we are able to use the word without ambiguity. What games share is a kind of ‘family resemblance’, claimed Wittgenstein. Only three years after Wittgenstein’s *Investigations*, Morris Weitz published the influential paper *The Role of Theory in Aesthetics* (1956). Weitz considered previous aesthetic theories of art as sharing the philosophical practice of essentialist definition. The problem with an essentialist definition of art is that the practices and products of art change, and so an aesthetic definition becomes redundant as a gap appears between theory and practice. To Weitz, therefore, any attempt to define art in terms of essential physical features of artworks is ultimately doomed to fail. As he saw it, “The problem is not “what is art?”, but “what sort of concept is ‘art?’” (1956, p.30). Weitz arrived at the conclusion that a closed concept of art is incompatible with the open practice of art; therefore art is an open concept.

Weitz used Wittgenstein's 'open concept' because art changes (but we still call it art), and used the 'family resemblance' argument because there are a number of overlapping properties (essences) that are shared by some but not all works of art. Hence, there are shared characteristics which are too sparse and mutable to be relied upon for the task of traditional essentialist definitions of art, and yet we can still use the word 'art' to refer to the practices and products that possess these essences. Strengths and weaknesses in the family resemblance argument can be illuminated with biological analogy: Much of the time, resemblances reveal actual connections. The taxonomy of species at first relied on visual identification, and only later conformed to relationships based on understanding of hereditary theory and genetics. We can see that chimps are very much like us, and indeed we share an almost identical genetic makeup. But resemblances may derive from family inheritance or from convergent evolution<sup>4</sup>, and we cannot always tell on the surface which is the case. A true family relation is one of shared inheritance of the sort that could be validated with genetic tests (such tests on fossilized and extant animals reveal our natural history and the evolution of species). So, as in biology, it is possible to be misled by appearances, and the family resemblance concept is not quite strong enough to get to the actual aesthetic inheritance. This is the argument used by Maurice Mandelbaum (1965) to criticise Weitz's employment of Wittgenstein's family resemblance concept, noting its lack of "genetic connections".

### **The Decline of Perception in Aesthetic Theory**

In the same way that Wittgenstein sought to end philosophy – and failed heroically, Weitz's argument to end the definition of art by a closed concept also failed. Weitz had a valid point, though, about the ever-changing nature of art and the failure of aesthetic theories to survive much beyond their contemporary artistic practices. Although the family

---

<sup>4</sup> An example of convergent evolution is the similar structure of octopus and human eyes. This fact baffled biologists for some time, since the two species are so far apart on the tree of life. The reason is that adaptation to similar environmental pressures led to the development of similar systems, and so the 'family resemblance' of these eyes belies the actual evolutionary path of the two species.

resemblance argument has been challenged for its weakness, the point about an aesthetic theory having to cope with the expansive variety of art is increasingly relevant. The strongest theories since Weitz have accepted this point, and in doing so they have moved the aesthetics of art further from the aesthetics of visual perception. For a brief period after Weitz's essay, there was a hiatus on the definition of art, but this did not last for long:

...had it not been for the neo-Wittgensteinians the temptation to define art might never have appeared so inviting. For nothing taunts a philosopher so well as the claim that something is impossible (Carroll, 2000, p.5).

The aesthetic definition of art resumed with Arthur Danto's concept of the artworld (1964) and George Dickie's institutional theory (1974). Their theories came about in a situation where the distinction between ordinary objects and artworks could no longer be taken for granted because of artists' appropriation of everyday objects (the 'readymade') and the incursion of art into sites beyond the gallery. Danto's essence of art is "something that the eye cannot descry – an atmosphere of artistic theory, a knowledge of the history of art: an artworld" (1964, p.580). For Danto, the artworld is "a world consisting of works of art, a self-enriching community of ontologically complex objects" (1993, p.204). This context allows us to distinguish between two objects which are perceptually identical, of which only one is a work of art. Reciprocally, the artworld also provides a context in which the 'transfiguration of the commonplace' (Danto 1981) can take place; everyday objects are transformed into works of art by their incorporation into the institutional mechanism of the artworld. Danto's canonical example is a mundane cardboard box used for containing and transporting *Brillo* soap pads, and Warhol's work of art *Brillo Box* (1964). The artworld is both what makes this box a work of art and what enables us to recognise it as such for the purposes of philosophical definition.

Weitz's open concept of art is evaluative, whereas Danto and Dickie offer classificatory or descriptive definitions of art. Classificatory definitions allow us to answer the question 'is this art?' In a sense, this has been a non-question in art practice for around

a hundred years, since Duchamp made the point that the more interesting and more difficult question is ‘what is good art?’ Danto’s theory avoids the difficult problem of classifying contemporary art in terms of the perceptual properties of art products, and instead provides a definition based on practice. As a defining ‘essence’ of art, the concept of the artworld is explicitly non-visual and thus non-aesthetic in the traditional sense of visual perception. Similarly, Dickie’s aesthetic theory is not based on the sensory perception of art, but relies on the identification of the social mechanisms of art. The difference is that Danto emphasises the importance of art history and art theory for ontologically identifying art, whereas Dickie emphasises the sociological aspects of the art world. Both are concerned with the context of art, and both are non-perceptual.

### **The Institutional Theory of Art**

Dickie opposes the idea of a special ‘aesthetic attitude’, as adopted by Beardsley. He argues against Beardsley’s three aesthetic conditions of value (unity, intensity and complexity), and against essentialist approaches to the aesthetic, saying that aesthetic perception differs only in motivation and not in perceptual qualities. In other words, Dickie thinks that in the appreciation of art we do not use anything other than our usual powers of perception. Like Danto, Dickie’s theory is non-perceptual; it is based on the same things that the eye ‘cannot descry’ – namely, the artworld. The institutional theory has undergone a few revisions, the latest of which Dickie calls ‘the art circle’ because it is based on a circular definition. Normally in philosophy, such definitions are avoided as being a vicious circle in logic, but Dickie defends the theory as a ‘virtuous’ circle. The art circle (1997) comprises these five statements:

1. An artist is a person who participates with understanding in the making of a work of art.
2. A work of art is an artefact of a kind to be presented to an artworld public.
3. A public is a set of persons the members of which are prepared in some degree to understand an object which is presented to them.

4. The artworld is the totality of all artworld systems.
5. An artworld system is a framework for the presentation of a work of art by an artist to an artworld public.

The five statements of the art circle flesh out the institutional theory of art by identifying the operative elements and their relationships. Substituting Danto’s somewhat vague notion of the artworld for a precise definition strengthens the theory overall by providing a more usable framework for classifying art. Despite its greater precision, the art circle still has the flexibility to accommodate new art practices and products. Note that although Dickie’s theory avoids the problematic essentialist definition of artwork properties, it nevertheless relies on the identification of the essential ontological elements that comprise the artworld: artist, artwork and audience. It is of course possible that these elements might change in the future artworld, just as the properties of artworks have changed, in which case the theory may need to be revised.

### Visual Models of Art

We can visualise the circular relation of Dickie’s theory as follows (Figure 17):

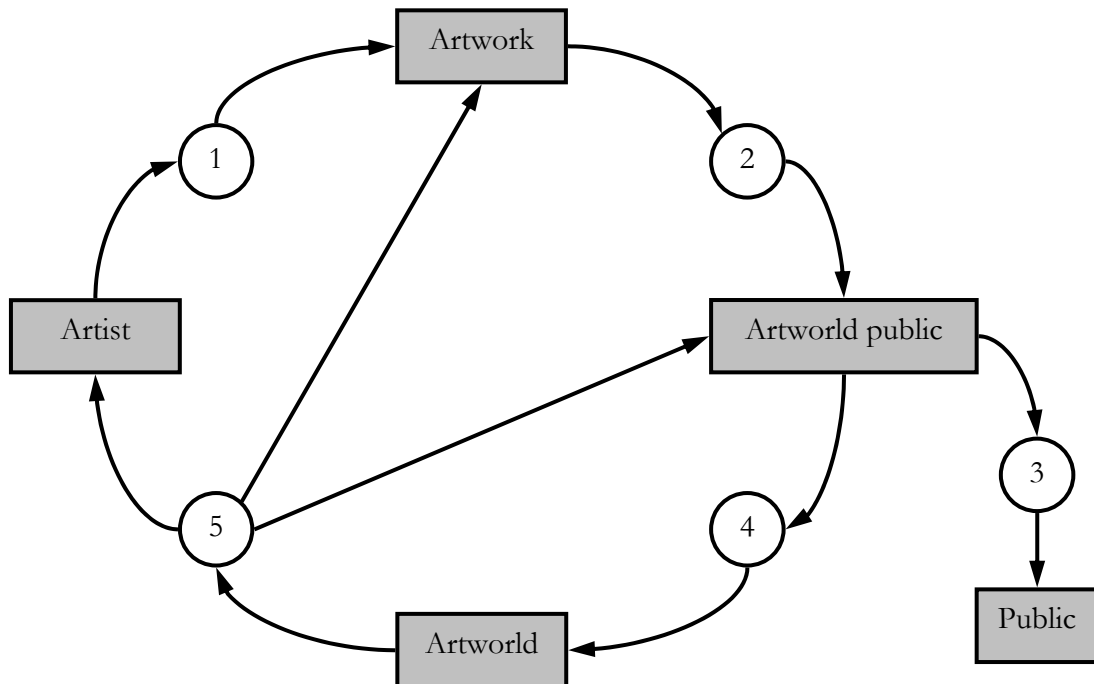

Figure 17 Visual representation of Dickie’s (1997) art circle.

This diagram illustrates the definitional connections of Dickie’s five statements (in numbered circles) that link the elements of the artworld (in shaded boxes). By slightly re-arranging the visualisation of the art circle, we can see that it is structurally similar to the working model of the aesthetic (Figure 18). The two models share a common set of ontological categories – artist, artwork, audience or artworld public, and artworld. From these visualizations, we can see that Dickie’s statement 3 leads nowhere. It fails to adequately define ‘public’ in general terms, and equally fails to separate fully from the ontological category ‘artworld public’. For this reason, it seems superfluous to the theory and it weakens the definitional relation of persons in the artworld with Danto’s concept of the artworld. If we were to modify the theory to fit our working model, we would replace the compound term ‘artworld public’ with the singular ‘audience’, which means that we could dispense with the superfluous statement 3. Statement 4 would then need to be reformulated along the lines of ‘the audience is the set of persons who, by engaging with artwork (i.e., appreciating, presenting, trading, criticising...), populate the artworld’, and statement 5 as ‘the artworld is constituted by the practices and products of those who make and engage with artworks’. The core theoretical structure would thus remain in place apart from the excision of the third statement.

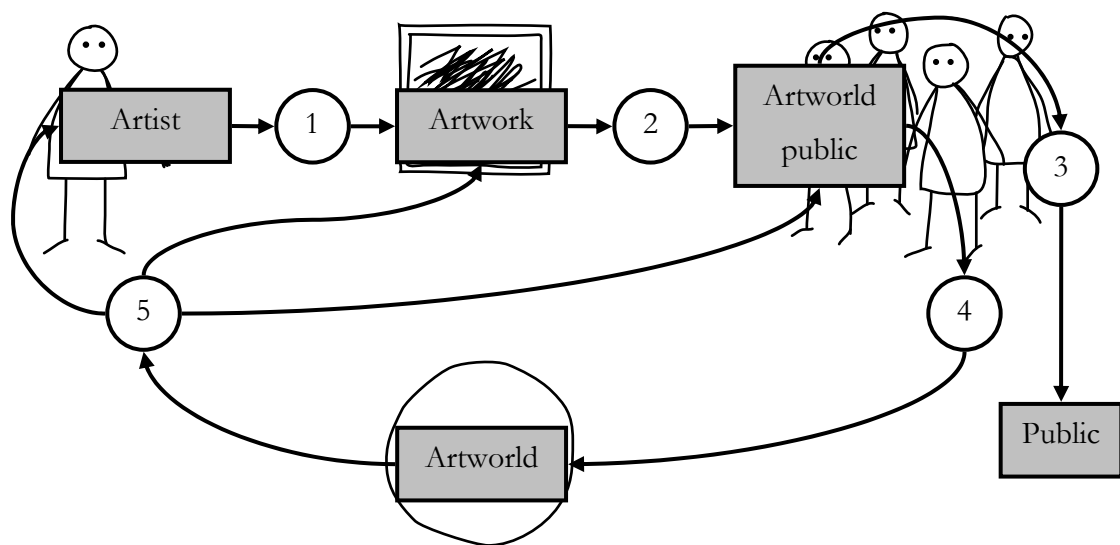

Figure 18 Visual representation of Dickie’s art circle mapped onto the working model of aesthetics.

It seems that Dickie never thought to visualize the art circle, since the texts in which the theory is published lack any such diagrams. In contrast, Arnold Berleant did illustrate his concept of the ‘aesthetic field’, which is related to the institutional theory of art. The central thesis of Berleant (1970) is that all factors of the aesthetic should be taken into consideration in regard to understanding the appreciation of art, thus aesthetics should be considered as a complex field of interacting contextual and aesthetic properties. This is certainly a significant point and an attractive idea, but the diagram itself (Figure 19) is difficult to read, and adds little in terms of explanation to Berleant’s thesis. Each element is connected to every other, and the arrows connect in both directions at once, which means that it actually says very little at all about the relationships between the elements except to say that they all influence each other at all times. In contrast to Dickie’s institutional theory, Berleant’s model employs four ontological categories: artist, artwork, audience and performer. The last of these is not present in Dickie (1997), whereas Berleant considers it an essential aspect of the aesthetics of classical music, for example, in which the composer occupies the role of artist and the musicians are the performers. The role of performer is of less relevance to the field of visual art on which the institutional theory is based, since it is not a defining element common to its practice. For the purposes of the current project, therefore, the role of the performer can be justifiably disregarded, as can Berleant’s model.



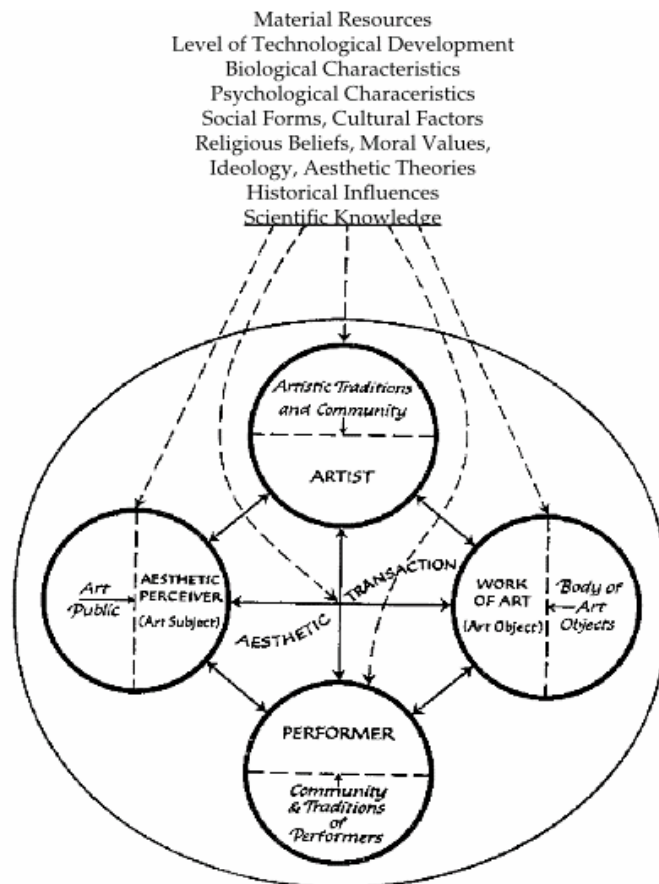

Figure 19 Berleant's (1971) diagram of the aesthetic field.

In examining the practice of computer art, Stroud Cornock and Ernest Edmonds (1973) visualize a series of art practices. They develop a theory of different art systems using a series of images to describe the relationship between artwork and audience (Figure 20). The art systems represented are dynamic in varying degrees, from the traditional passive viewing of an artwork to a fully interactive relationship. These diagrams do not include the role of the artist, because the purpose of the study concerns a particular form of art practice and does not aim to offer a universal theory of art. Instead, the diagrams illustrate what goes on in the everyday experience of an artwork, where the artist is not usually present and is not a necessary part of the work. It would be possible to incorporate these models into the working model of aesthetics, which would place the dynamic art systems in the larger context of the artworld and refine the working model to a more specific kind of practice. But because the focus of the current project excludes dynamic and interactive art, however, Cornock and Edmond's model is not deployed in this thesis.

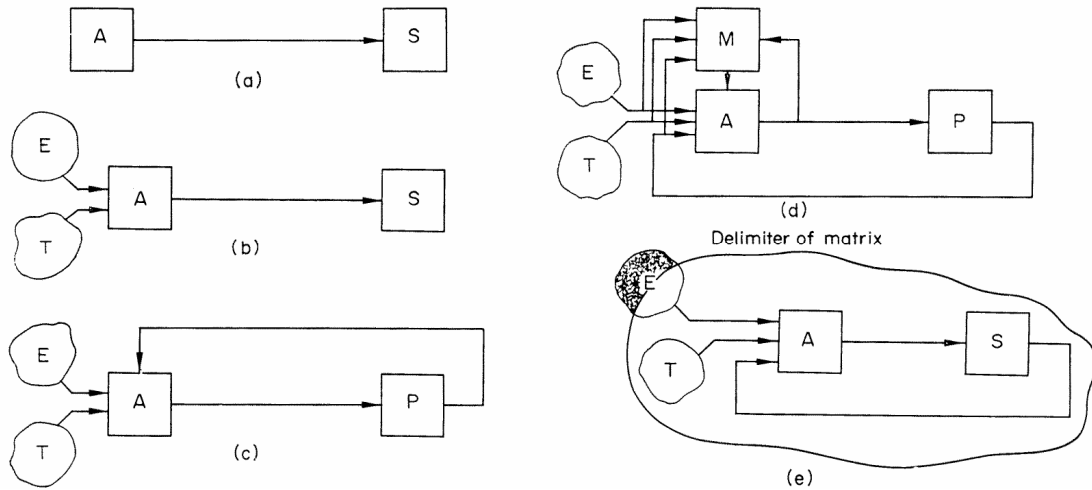

Figure 20 Cornock & Edmonds (1973). Visualization of art systems: (a) static; (b) dynamic-passive; (c) dynamic-interactive; (d) dynamic-interactive (varying); (e) matrix. Key: A = artwork, S = spectator, E = environment, T = time, P = participant, M = modifier.

## Relational Aesthetics

By avoiding the problems of defining art based on essential properties, Dickie claims that the art circle offers a workable theory that allows room for changing art practices: “The institutional theory allows the freedom for which Weitz quite correctly is so anxious to preserve in his attack on traditional theories of art.” (Dickie, 1997, p.110). In so doing, Dickie’s theory distances the aesthetic from the perceptual, as does Danto’s concept of the artworld. A more recent contribution to this development comes from Nicolas Bourriaud’s *Relational Aesthetics*, which is an “aesthetic theory consisting in judging artworks on the basis of the inter-human relations which they represent, produce or prompt” (2002, p.112). Like Danto and Dickie, Bourriaud attempts to grapple with the incursion of the everyday into the world of art, the difference being that Bourriaud’s theory mainly addresses art events rather than art objects. The theory focuses on the non-perceptual social relations that are engendered in art practices of the 1990s (notably, of those practices represented in Bourriaud’s own curatorial projects). The examples of relational art include the work of Rirkrit Tiravanija, Felix Gonzales-Torres, Vanessa Beecroft, and Liam Gillick. Because some of this artwork would be indistinguishable from everyday happenings were it not for

the context of the artworld, they represent the type of practice for which the institutional theory was developed. According to Bourriaud, what makes these practices ‘relational’ is that they “take as their theoretical horizon the realm of human interactions and its social context, rather than the assertion of an independent and private symbolic space” of, for example, Modernist art (2000, p.14). This relational art, Bourriaud says, takes Duchamp’s notion of the audience as contributor to the artwork a step further, “by postulating dialogue as the actual origin of the image-making process” (2002, p. 26).

We can use the working model of aesthetics to understand Bourriaud’s concept. This can be illustrated with a personal story of when I met the artist Xavier Roux at an exhibition in Washington DC in 2007. Xavier’s artwork involved sitting with him on a portable wheelbarrow/chair that he had made, and engaging in discussion with the artist. (Part of the work required those who engaged with the artist to report back if dreams about the wheelbarrow were experienced later on.) In our discussion I explained my research, drawing the working model of the aesthetic (Figure 6). He re-drew the diagram to illustrate his own practice – he omitted the artwork from the diagram, joining the artist and audience with a single line. For Xavier, he explained, this direct interaction is the artwork, and is the kind of practice described in Bourriaud’s relational aesthetics.

Bourriaud defines the practice of art as “an activity consisting in producing relationships with the world with the help of signs, forms, actions and objects” (2002, p.107). Whilst this definition is certainly inclusive in the way that Weitz (1956) advocated, it is difficult to see how it is useful in separating what artists do from any other field of human enquiry or creativity (admittedly, Bourriaud does not rely on this definition to support his theory). A more serious criticism of Bourriaud comes from Claire Bishop (2004), who questions what kind of interaction is actually desirable in relational aesthetics: Is the meaning (and therefore also value) of relational art actually developed “collectively”, as Bourriaud suggests, and if so, why is it that the artist still appears to be in control and remains the one person to whom these artworks are attributed? Looking back at Dickie’s

art circle, an artist is someone who “participates *with understanding* in the making of a work of art” (Dickie 1997, my emphasis). Only with understanding comes the right to authorship. The audience-participants in Bourriaud’s examples of relational art cannot be said to have full understanding. In fact the opposite seems to be the case with the work of Tiravanija and Gillick, in which the audience has no instruction for participation and the ‘rules of the game’ are unclear if not actually obscured or withheld. Bishop also notes that “the *quality* of the relationships in “relational aesthetics” are never examined or called into question.” (2004, p.65). It is a reasonable point, and it seems the same could be said for the similarly non-perceptual theories of Danto and Dickie: Both relational aesthetics and the institutional theory of art lack the explanatory power of the earlier closed-concept definitions of art such as Beardsley’s. These non-perceptual aesthetic theories of art are unable to explain why we value some artworks over others or why we should do so. The current situation is that in the context of non-perceptual aesthetics, “political, moral, and ethical judgments have come to fill the vacuum of aesthetic judgment” (Bishop, 2004, p.77). My thesis is that an empirical investigation of aesthetics has the opportunity to fill some of these gaps in the non-perceptual theories of art. But whether a return to a perceptual theory of art also has the potential to account for the aesthetic judgement of ‘everyday’ artworks and relational art practices remains to be seen.

## Summary

Historically, aesthetic discourse has served to theorize the practices of making and appreciating art, whether it is concerned with perception in general or with art in particular. Philosophy has provided the ontological and epistemological foundations for an investigation of aesthetic questions. Contemporary aesthetic theories have to contend with an artworld which is more diverse than ever before, simultaneously made more interconnected and more fragmented in the process of globalization. The most successful aesthetic theories are those that survive as art history accumulates and the density of available information increases. Amongst the most successful today include the theories

that incorporated Wittgenstein's ideas on definition, in which meaning is defined by use. This idea has shaped aesthetic theory by changing its focus from the products to the practices of art, and in so doing the field has moved away from perception.

Contemporary aesthetics is dominated by the a-perceptual theories of Weitz, Danto, Dickie and now Bourriaud. Most of these theories are essentially answers to the question 'what is art?', but we have noted that this is an old question in art, and that the more interesting question is what makes good artworks valued in the way that they are. Bourriaud's theory claims to provide such a criteria, but it only applies to a specific subset of contemporary art practice, and even in that regard it is not without problems. In an article entitled *Is Psychology relevant to the Arts?* (1961), Dickie comes to the firm conclusion that it is not: "I am convinced that the problem of the description of the nature of aesthetic experience is not a task to which the techniques of empirical science are relevant" (p.302). On the contrary, I believe that empirical investigation can fill the gaps in non-perceptual art theory by explaining why we value art and what makes it good. Even as contemporary art practice and theory have moved away from the traditional perceptual core of aesthetics, we still perceive and understand art through our senses. For this reason, I suggest that we should look again at the perceptual aspects of visual art which are neglected in contemporary aesthetic theory.

My argument is that visual complexity is a contributing factor in aesthetic value, and that a theory of aesthetic value has the opportunity to fill the gaps in the non-perceptual theories of art. Visual complexity is just one of these perceptual aspects, but it is a valuable one because it encompasses other, more fundamental perceptual properties, such as the quantity, variety and order of picture elements. If we can understand how visual complexity is manifested objectively and perceived subjectively, then we may be able to learn how it contributes to the aesthetic perception of visual art. The next section of this chapter presents the findings of empirical aesthetics that explore these questions in terms of the measurable objective and subjective properties of visual complexity.

# Empirical Aesthetics

This section provides a history and evaluation of developments in the scientific study of aesthetic perception. It is presented in approximately chronological order, beginning with an introduction to the issue of psychophysical measurement. The review narrows from the general to the more specific concerns of this project – from the foundation of empirical aesthetics as an academic discipline to the development of experimental methods within the field. Because the focus is on visual perception, this review is largely restricted to aesthetics of visual art. The discussion incorporates the application of concepts from complex systems and information theory which were introduced in Chapter 1, and puts these in relation to empirical knowledge of visual perception.

## Establishment of the Field

One aspect that distinguishes empirical aesthetics from philosophical and artistic aesthetics is a willingness to adopt a quantitative approach to the subject. Whether aesthetic objects and aesthetic perceptions can be justly quantified without losing significant properties has remained in debate since the beginnings of empirical aesthetics. Dickie (1961), for example, rejects psychological findings as irrelevant to aesthetic questions, and would not admit of their value to art theory. We negotiate some of these difficulties in this chapter and the next. Primarily, these problems arise due to the subjectivity of perception.

The subjectivity of sensory perception causes two problems for empirical studies: Firstly, perceptions are not directly accessible to inspection for experimental purposes, and secondly they are highly variable. If we can accept a general abstraction of aesthetic perceptions, then the latter problem can be resolved through duplication of tests and averaging of results. In this way we can approximate the trends of an individual or a group. But we are still left with the former difficulty, namely, how to measure these subjective perceptions in the first place. What is required is some way of quantifying the psychological events of perception. Perceptions generally vary along a continuum, e.g. from dark to bright or cold to hot, and the challenge is to partition the continua in such a way that they

can be measured. If they can be measured, then their relationship to the intensity of physical stimuli can be determined. The field that concentrates on the relationship of physical properties to perceptual properties is known as psychophysics. Thus the primary task of early psychophysical measurement was the construction of a perceptual scale, which is where the following section begins the review of empirical aesthetics.

### **The Measurement of Perceptions**

One of the oldest psychophysical procedures is called equisection – the partition of continua into equal-appearing divisions. If a scale is divided in two, the method is called bisection. This method was invented by Joseph Plateau (1801–1883), when he gave eight of his artistic friends black and white oil paints and asked them to paint a mid grey between the two (Stevens, 1975, p.154). Even though the artists carried out this task rather unscientifically in different locations and lighting conditions, the greys they produced were very similar when viewed in the same setting (Laming & Laming, 1996). From this simple beginning, it is then only a small step to repeat such tasks and to build a scale by continued subdivision.

Just how far can we take this process of subdivision? This is what concerned Ernst Heinrich Weber (1795–1878), who formulated the idea of the ‘just-noticeable difference’ (JND). Weber’s method was to present a subject with a stimulus and to adjust it slightly until the subject reported that they could perceive a difference. For example, in one experiment a blindfolded subject holds a weight and reports when they notice a difference as weights are added. The results showed that the JND grows in proportion to the stimulus, i.e. if the weight being held is doubled, so does the amount that needs to be added to achieve a noticeable difference. JND values are given with reference to the percentage of trials in which the subject detects a difference – usually 50%, although other values are sometimes used. Through these experiments, Weber had created a law that related physical stimuli to psychological perceptions. He had found that the JND is a constant proportion of the strength of the stimulus, which can be written as:

$$\frac{\Delta\Phi}{\Phi} = k$$

where  $\Phi$  (phi) is the stimulus intensity,  $\Delta\Phi$  is the JND ( $\Delta$  means ‘difference’), and  $k$  is a constant that signifies the proportion of the JND to the stimulus. N.B. Even though it relates to perceptions, the JND is measured in the physical units of the stimulus, i.e. *how much* of the *stimulus* is perceived.

The JND amounts to a perceptual threshold; it represents the discriminating ability of our senses. Although Weber’s formula describes a relative threshold, the same idea can be applied to the extremes of sensory continua in order to determine an absolute perceptual threshold (e.g. how quiet a sound we can hear), which provides a useful upper or lower point of reference for a perceptual scale. In psychophysics, there are three common methods used to find perceptual thresholds: the method of limits, the method of constant stimuli, and the method of adjustment.

The method of limits was invented by Wilhelm Wundt (1832–1920). It involves the steady increase or decrease of stimuli until they are reported as being perceived or not. Different results are found depending on whether the ascending or descending method of limits is used, so some experimenters use both methods and then average the results. The biophysicist Georg von Békésy (1899–1972) offered an alternative called the ‘staircase method’: The stimulus is reduced until it passes below the threshold, then increased until it is perceived again, and so on until a steady value is found. In order to reduce the errors of habituation and expectation, the method of constant stimuli presents a random succession of various intensities, and the subject reports whether they are perceived. In the method of adjustment, the subject controls the stimulus level, and their task is either to match another reference level or to adjust it to a given threshold.

Weber is often credited as ‘the father of psychophysics’ for his foundational work on the JND, but others claim the title for Gustav Theodor Fechner (1801–1887) because he was the first to bring a quantitative approach to the problem and to measure perceived



sensations. After he became aware of Weber’s work, Fechner made a significant contribution to the establishment of psychophysics as a science via the publication of *Elemente der Psychophysik* in 1860 (Fechner 1966). What we currently recognise as psychophysics forms only one of two domains prescribed by Fechner; the one that he called ‘outer psychophysics’, which relates physical events to the mental. ‘Inner psychophysics’ would deal with the relation between mental and neural events. Although it does not exist as yet, a field of inner psychophysics may be realised as the relatively young disciplines of neuroscience and consciousness studies continue to develop.

Fechner formulated the first psychophysical function – a quantitative relation of stimulus intensity to perceived sensation – which had a great influence on psychophysics (Stevens, 1975, p.7). He reasoned that if we could create equal units of sensation, then by counting the number of units between two stimuli levels – as in those found by equisection – we would be able to measure sensations. To Fechner, Weber’s JND provided such a unit. He named his psychophysical function in honour of Weber, but it is now known as the Weber-Fechner law:

$$\Psi = k \log \Phi$$

$\Psi$  represents sensation,  $k$  a constant, and  $\Phi$  the stimulus intensity. N.B., the Greek letter  $\Psi$  (*psi*) denotes *psychological* measurements, while the letter  $\Phi$  (*phi*) denotes *physical* values.

In formulating this function, Fechner had made the assumption that the JND formed *perceptually equal* divisions of a sensory scale: He assumed that as the physical size of the JND ( $\Delta\Phi$ ) increases with stimulus intensity ( $\Phi$ ), as Weber had found, *its perceptual size* ( $\Delta\Psi$ ) *does not*. This meant that his psychophysical equation described a logarithmic relationship between stimulus and sensation. In other words, as one value (the stimulus intensity) is multiplied, the other (perceived sensation) is only added. It turns out that Fechner’s logarithmic equation only holds true for a few perceptions, because his assumption about the JND was wrong. Despite suggestions for an alternative to the

logarithmic function in 1728 by Gabriel Cramer (Stevens, 1975, p.3) and by Plateau in 1872 (Laming & Laming, 1996), the Weber-Fechner law continued to be used for the next hundred years (Wixted, 2002).

Stanley Smith Stevens (1906–1973) was the first to successfully challenge Fechner’s law, and had a large impact on experimental psychology. Whereas Fechner’s measure was based on the units of the JND, which were defined by the experimenter, Stevens’ approach was to ask the subject to quantify their own sensations. Instead of trying to construct a scale, he reasoned, let us use the one that the subjects bring with them – the concept of numbers that we use so frequently in our daily transactions. In the first applications of this method during the 1950’s, the experimenter provided a value for the first stimulus, and subjects were asked to apply successive numbers in relation to this value. Stevens soon realised that this was unnecessary. Subsequent tests abandoned the fixing of the first value, leaving it to the discretion of each subject, and later equalised their various scales to a common modulus. When Stevens’ method – called magnitude estimation scaling (MES) – was applied to psychophysical experiments, the results did not accord with Fechner’s function (Stevens, 1957). In the influential paper *To Honour Fechner and Repeal his Law*, Stevens (1961) argued that “a power function, not a log function, describes the operating characteristic of a sensory system.” (p.80). Stevens’ power law, as it is known, is written:

$$\Psi = k \Phi^\beta$$

Again,  $\Psi$  is the perceived sensation,  $\Phi$  the stimulus intensity, and as Stevens said: “The constant  $k$  depends on the unit of measurement and is not very interesting; but the value of exponent  $\beta$  serves as a kind of signature that may differ from one sensory continuum to another.” (1975, p.13).

When the results of magnitude estimation are plotted, the graphs show logarithmic curves like those in Figure 21a. If the function is instead plotted on logarithmic axes (Figure 21b) the results produce straight lines, the slope of which can be used to determine

the value of the exponent  $\beta$ , by dividing the  $y$  value by the  $x$  value. For example, the slope of the dashed line in Figure 21b can be calculated by reading its end point, which has  $x$  and  $y$  values of 6 and 2 respectively (if we count the notches on the axes), and so the value of  $\beta$  is  $2/6 \approx 0.3$ .

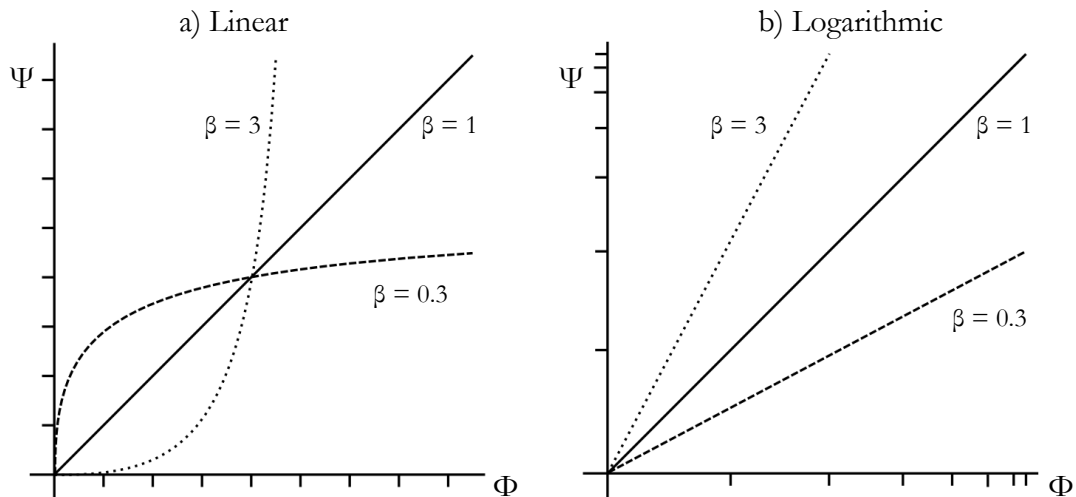

Figure 21: Linear and logarithmic plots of idealised psychophysical functions: how perceived sensation ( $\Psi$ ) varies with stimulus intensity ( $\Phi$ ) for different  $\beta$  values.

Exponents with  $\beta$  values less than 1 indicate sensory continua such as loudness ( $\beta = 0.67$ ) for which sensation increases more slowly than the stimulus, which enables us to hear a very wide range of volumes. Conversely, continua that increase more rapidly than the stimulus value have an exponent greater than 1, which is the case for electric shock ( $\beta = 3.5$ ). For continua with an exponent of around 1, perceptions are proportional to the stimulus, as in estimations of coldness and visual length (Stevens, 1975, p.15). The differences in sensitivity to stimulus intensity, which are characterised by Stevens' power law exponent  $\beta$ , often reflect evolutionary adaptations. It is not hard to see why being more or less sensitive to particular situations is useful, for example, the survival value of visual accuracy in estimating distance. The results of Stevens' method of magnitude estimation demonstrated that many sensory continua are better described by a power law relation than by Fechner's logarithmic function. Stevens' power law is an example of the occasionally

surprising effectiveness of empiricism and mathematics to describe patterns in our world, a matter of which he was well aware:

Regardless of how successful quantification may prove to be in all the rest of science, in psychophysics it has yet to shake off all suspicion, for there lingers in many of us a feeling, not only that human experience is somehow inscrutable, but also that measurement, because of some flinty rigor, may lacerate the human spirit if we probe too deeply with the aid of scales and numbers. (Stevens, 1975 p.51)

Stevens' method demonstrates that it is possible to measure what was previously considered un-measurable, and the results of this method fit the power law relation for which he argued. Although these are valuable contributions to the field of psychophysics, there have been a few issues with his work. One of these concerns the way in which Stevens treats the measures derived from his experiments as ratio scales. Some have objected to the assumption of a ratio scale, and say that such methods first require empirical proof that perceptions actually behave this way (e.g. Narens, 1996). Such arguments are matters of representational measurement theory, and are too complicated to describe here (see chapter 1 of Wixted, 2002 for a concise overview). Despite these issues, Stevens' ideas about the different types of scales used in measurement remain amongst his most influential contributions to psychology (Teghtsoonian, 2001).

To complete this summary of the history of psychophysical measurement, let us look briefly at a less significant but interesting contribution which relates to the properties of various sensory modes: Stevens (1975) makes a distinction between two types of perceptual continua, which are named *prothetic* (quantitative) and *metathetic* (qualitative). In hearing, loudness forms a prothetic continuum because it varies as a magnitude or scalar quantity. On the other hand, the pitch of a sound is metathetic because it depends not only on its absolute pitch but also on its relation to other pitches. Another way to clarify the difference between the two is to imagine what happens when stimuli are combined. Adding two

sounds that differ in volume and pitch will result in an increase of loudness<sup>5</sup> (which is a prothetic quantity), but not an ‘increase’ in pitch (which is a metathetic quality). This suggests that it may be more accurate to think of continua as varying in dimensions, or degrees of freedom, instead of a cruder categorisation by quality and quantity. Loudness is quantitative because it has only one degree of freedom, as does the linear scale of real numbers. Pitch has at least two degrees of freedom; its value is described not only by its absolute frequency (middle C = 261.63 Hz) but also by the frequency of the note relative to others (C is a semitone above B and a whole tone below D), which is itself an intricate affair. Taste has at least five dimensions (salt, sweet, sour, bitter, and umami) and is further complicated by its close relation to smell, which has many more.

These sorts of complex relationships characterise the objects of study in empirical aesthetics. The way in which we categorise the elements of such relationships influences the type of questions we can ask and the type of answers we may find. The distinction between metathetic and prothetic percepts is not widely used in the psychological literature, yet these kinds of characteristics are clearly of great concern to those who deal with aesthetic matters. Whether the aesthetic perception of visual complexity is best described as a quantitative or a qualitative continuum is not yet clear.

### **The Measurement of Perceived Complexity**

Fechner was among the first to consider complexity in terms of aesthetic perception. In the *Vorschule der Aesthetik* (1876), he proposed ‘the principle of the aesthetic middle’, which stated that too much or too little complexity detracts from aesthetic appreciation. This proposition was one of sixteen aesthetic principles published in the *Vorschule* which were empirically unverified at the time, but which were later supported by Berlyne’s (1971) findings. In the landmark publication *Principles of Physiological Psychology* (1874), Wundt considered the effect of novelty on aesthetic experience, and observed that the

---

<sup>5</sup> Loudness is the name given to the subjectively perceived intensity of sound; volume is the name of the corresponding objectively measured intensity: If the *volume* of sound is too high, it may be too *loud* for us.

pleasantness of perceptions varies with stimulus intensity in terms of an aesthetic middle. Daniel Berlyne (1922–1976) describes the principle in terms of a measurable aesthetic ‘dimension’:

If, as one proceeds along a certain dimension, beauty or pleasure or aesthetic value rises for a while, reaches a maximum in some intermediate state, and then falls as the opposite extreme from the starting point is approached, we have an example of the inverted U-shaped curves that are quite often encountered in psychology. (Berlyne, 1971 p.124)

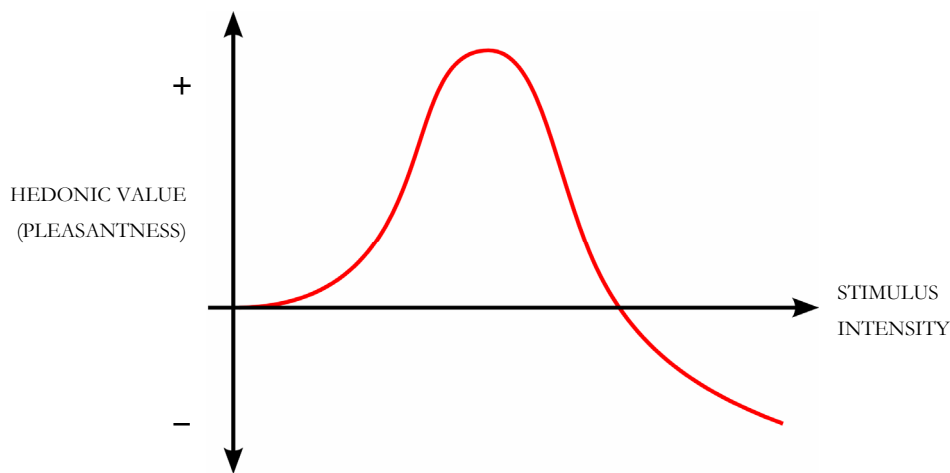

Figure 22 The Wundt curve (adapted from Berlyne, 1971 p.89).

Wundt was the first to provide empirical evidence for this psychophysical relationship, and the resulting inverted U-shaped curve is named after him (Figure 22). We can understand aesthetic complexity in these terms, too. If we can quantify and manipulate the complexity of stimulus images, we may be able to carry out an empirical investigation to test the hypothesis of the aesthetic middle for visual complexity.

Measuring subjective perceptions of aesthetic properties can tell us much about individual perceptions and individual works of art, but it is difficult to compare and infer from these studies due to the variability and specificity of their results. An objective measure, on the other hand, can be used to construct a scale to which subjective data can be compared. If we can determine the (mathematical) relationship between the two scales, we could use the objective method to predict perceptions of other measured artworks. This

was among the methods adopted from experimental psychology that Berlyne (1971) applied to aesthetic questions. Berlyne's results led to his theory of aesthetic preference in terms of *arousal*, which can be regarded as a measure of alertness or excitation (1971, p.64). His theory, which proposed an inverted U function of preference for arousal values of aesthetic variables, "dominated the field of experimental aesthetics for the past several decades" (Martindale, Moore & Borkum, 1990, p.53). Seven experiments by Martindale and colleagues (1990) provided enough empirical evidence to disprove this theory, they claim. Their methods, however, were the same that Berlyne had pioneered and which continue to be used (the authors say that the experiments were ones that Berlyne was likely to have carried out himself, had he not died suddenly).

To quantify the intensity of aesthetic stimuli, George D. Birkhoff (1884–1944) proposed an 'Aesthetic Measure' in a book of the same name (1932). Birkhoff studied the forms of 2D abstract shapes and silhouettes of objects, such as vases, and he came up with a formula which attempted to capture the 'unity in diversity' of beauty (Barrow, 2003, p.2). His method was to measure aesthetic value in relation to geometrical properties. The aesthetic measure ( $M$ ) varied in proportion to the amount of order ( $O$ ), and inversely in relation to complexity ( $C$ ):

$$M = \frac{O}{C}$$

Birkhoff defined complexity as the number of straight lines that make up a shape, while order is derived from a complicated summation of symmetries (Barrow, 2003, p.3). With this equation, simple figures such as a square have a high  $M$  because they have more order than complexity. One problem with this aesthetic measure is that it is impractical to apply to most artworks, whose complexity and ambiguity make such measurement virtually impossible. Another problem is that it does not account for the complexity of art, nor why we tend to value complex images. Contrary to Birkhoff's results, psychological experiments with geometric shapes by H.J. Eysenck (1916–1997) revealed preferences for high order and high complexity. Examples of the stimuli are illustrated in Figure 23. The results of

Eysenck's experiments (1941a; 1941b) prompted him to re-formulate the aesthetic measure (1971, p.164) as follows:

$$M = O \times C$$

When put this way,  $M$  increases with complexity, as opposed to Birkhoff's formula in which  $M$  decreases as complexity increases. Yet either theory seems counter-intuitive; it seems more likely that the highest preference would be found between the extremes of complexity, as Fechner's principle of the aesthetic middle and the Wundt curve would suggest. Birkhoff and Eysenck had empirical support for their respective theories, however, and Fechner had not. The difference in both the stimuli and the measure of complexity used by each of the experimenters confounds a comparison of their results. But what we can say is that Birkhoff merely *assumed* that complexity was a necessary element of an aesthetic measure, whereas Eysenck had *demonstrated* that complexity was a factor in the determination of aesthetic preference. The implication is that Eysenck's formula was supported by his experimental results because he only looked at a section at the low end of the complexity spectrum, for which our preference does appear to increase with complexity: It is in effect just the left-most section of the Wundt curve (Figure 22), if we replace 'stimulus intensity' with 'complexity'. It suggests that if Eysenck had examined a wider range of complexity – that is, had he included much more complex stimuli – then it is possible that the results would have fitted the Wundt curve, and so the rather simplistic equation  $M = O \times C$  would have had to be revised.

Eysenck's (1941b) experiments with geometric figures (Figure 23) led to the proposal of what he called  $T$  and  $K$  factors of aesthetic preference (1941b). The  $T$  factor describes a general tendency, similar to Birkhoff's aesthetic measure  $M$ , which Eysenck conceived as an analogue of (psychologist and statistician) Charles Spearman's  $g$  factor, which is an established measure of general intelligence (McWhinnie, 1965, p.35). Within the general  $T$  factor, i.e. when its effects have been eliminated from the results, another factor is revealed. The  $K$  factor describes a bipolar division of preference for "...simple polygons, simple



rhythms, and highly unified pictures as compared with a preference for complex polygons, loose rhythms, and diversified pictures.” (McWhinnie, 1971, p.116). Eysenck’s theory was based on the psychology of personality types, and although it did not determine what caused these preferences, a study by Harold McWhinnie (1966) suggests that the *K* factor might be attributed to learning as well as personality.

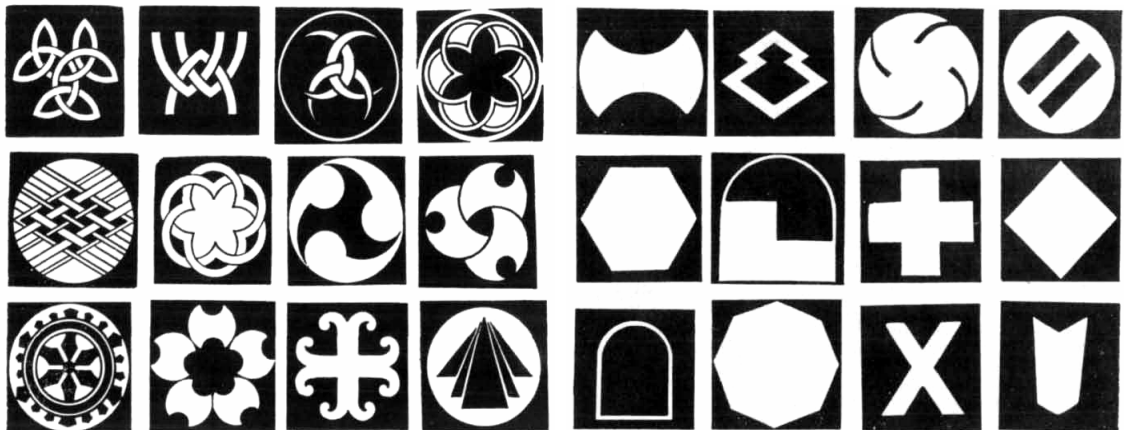

Figure 23 The twelve most-liked (left) and least-liked (right) of Eysenck’s (1941b) experiments.

Eysenck (1941c) also performed tests on colour preference using ten cards based on Ostwald’s (1969) colour system. As with his earlier experiments, he found a general aesthetic factor (the *K* factor, in which subjects tended to agree on colour preference ranking) and a second bipolar (*T*) factor – in this case a preference for either saturated or unsaturated colours. In Eysenck’s experiments, single groups were tested which were then categorised according to the results. A few years later, Frank Barron took the opposite approach by starting with different groups of people and comparing their preferences. Barron’s (1952) experiments investigated aesthetic preference between artists and non-artists. His method was to use images from the Welsh Figure Preference Test<sup>6</sup> (Figure 24), testing preferences for either simple-symmetrical or complex-asymmetrical figures.

---

<sup>6</sup> A non-verbal personality test comprising a set of 400 black and white images and a response choice of like/dislike.

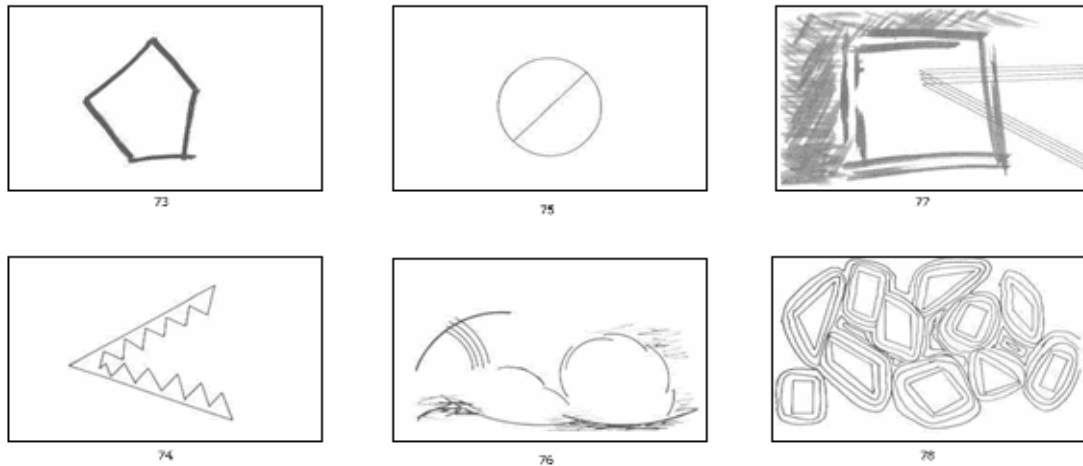

Figure 24 Example images from the Welsh Figure Preference Test

Barron concluded that artists had a higher preference for the complex-asymmetrical figures. A later experiment using reproductions of artworks (Barron, 1963) found that the artist groups also preferred art that was “...modern, radical, experimental, primitive, and sensual” (McWhinnie, 1971, p.116). Barron’s tests failed to differentiate between the effects of training and personality, since the artists may have had a predisposition for liking complex-asymmetrical images before the influence of their art training. Nonetheless, his correlation of artistic creativity with preference for visual complexity fits with Eysenck’s findings about the *K* factor, and has been corroborated by later experiments (e.g. Eisenman, 1967).

Berlyne (1971) identifies four variables that contribute to visual complexity: Irregularity of arrangement, amount of material, heterogeneity of elements, and irregularity of shape (of elements). Berlyne also identified four classes of complexity, compiled from his own experiments and those of others, which are comparable to Wolfram’s (2002) classification: I. Regular arrangement, small amount of material, homogeneous, regular shapes. II. Irregular arrangement, more material, heterogeneous, irregular shapes. III. Fewer independent units, symmetry, non-randomised. IV. More independent units, asymmetry, randomised (1971, p.198). If there is a problem with this classification, it is that it appears a little too complicated or even arbitrary; there are many factors involved in the categories which might be better understood in isolation. Nevertheless, Berlyne identifies

some of the significant visual properties that contribute to the perception of visual complexity.

In summary, there are two critical factors in aesthetic experiments of visual complexity: the way in which complexity is defined and measured, and the range of complexity present in the stimuli. There have been many attempts to define complexity in terms of aesthetic properties, and many different approaches to its classification and measurement. The lack of common measures of visual complexity hinders comparison between studies. In addition, the complicated nature of complexity measurement often restricts studies to relatively simple geometric shapes which are more amenable to analysis. In the next section of this chapter, we examine the influence of information theory on the field of empirical aesthetics. We discuss the ways in which it surmounts the limitations of previous measures and provides a common ground for the measurement of aesthetic properties, particularly for visual complexity.

## **The Influence of Information Theory**

In this age of computing technology, *information* has become a familiar concept, though perhaps one that is not always well-understood. It is most frequently used to describe abstract quantities of data, particularly in computing, but the origin of the word relates to the formation of materials or concepts. To the ancient Greeks, the perception of beauty was an experience based on the sensory in-formation of the Platonic forms embodied in material objects. The way in which the concept of information became useful to contemporary empirical research rests on its modern meaning, with its emphasis on quantification. The birth of information theory in the 1940's coincided with the first digital computers, which had resulted from a confluence of mathematics, physics and electronic engineering. In effect, computing is applied information theory. Yet the very first digital computer – the Z3, built in 1941 by Konrad Zuse – preceded by seven years the paper that provided the foundation of information theory – Claude Shannon's *A Mathematical Theory of Communication* (1948). The significance of Shannon's paper is that it formalises a theory of

communication by quantifying information through the concepts of order, probability and redundancy. The quantification of information provides a potentially useful tool for scientific experiments because it allows for the measurement of aesthetic properties. In addition, information theory offers to art theory and practice a new way of understanding aesthetic properties and perceptions.

### **Concepts from Information Theory**

Fred Attneave (1919–1991) was amongst the first psychologists to apply information theory to aesthetic problems. In *Applications of Information Theory to Psychology*, Attneave credits the idea that information is precisely measurable to Shannon (1948) and Norbert Wiener (*Cybernetics*, 1948), whose work offered a “shiny new tool kit” to which “more than a few psychologists reacted with an excess of enthusiasm” (1959a, p.v). Attneave identifies the significant element of this new field:

Perhaps the most fundamental concept of information theory is that of a continuum extending from extreme lawfulness, or redundancy, or regularity on one hand, to extreme disorder, or unpredictability, or uncertainty on the other. One end of this continuum is homogeneity, the other chaos. (Attneave, 1959b, p.503)

This is the idea, introduced in Chapter 1, upon which various informational measures of complexity are based. We noted then that an informational measure is inconsistent with the intuitive notion of complexity. The former is a scale of order–randomness, and the latter is understood as a scale of simplicity–complexity. Whilst there is some agreement between the concepts of order and simplicity (the lower ends of the two scales), there is a notable difference between randomness and complexity (the upper ends). The difference is not just conceptual, but also perceptual: Attneave (1954, p.188) notes the point that random images can give the subjective impression of homogeneity, which is the opposite end of the informational scale. An image made of 50% random black and white pixels has a maximum measure of information content, but it is homogeneous in texture and may be perceived as a simple uniform grey (if the pixels are small enough).

One of the earliest writers on information theory and visual aesthetics was Max Bense (1910–1990), a scientist-turned-art-theorist who published *Aesthetic Information* in 1957. Bense’s ‘information aesthetic’ treats art as a form of communication, modelled on the information-theory approach. Bense adapts Birkhoff’s (1932) aesthetic measure to the informational framework by substituting elements of the formula  $M=O/C$ , replacing order with redundancy, and complexity with statistical information (Walther, 2000). In so doing, Bense incorporates the central concept of information theory, the scale of order-to-randomness, into an aesthetic measure. Bense makes a distinction between semiotic and numeric aesthetic information; only the latter is open to analysis with information theory, which deals principally with quantitative data.

Like Bense, the communication theorist Abraham Moles (1920–1992) distinguished two types of aesthetics information – semantic and aesthetic. Whereas semantic information is expressible in symbols and is translatable, aesthetic information is untranslatable – it is not the message (its meaning) but the way that the message is conveyed (such as its medium, syntax and context). Moles used information theory to focus on the aesthetics of music. By its temporal nature, music fits naturally into an information theory framework of communication which is based on linear, time-dependent sequences. The aesthetic information of an object is a quantitative measure of the order/randomness of its internal structure which provides a scale of reference for the measurement of perception. Semantic information refers to things external to a sound or an image, whilst aesthetic information has to do with the internal set of relations in the structure of pictorial or musical elements. Therefore, semantic information is generally beyond the scope of analysis for an information-based empirical investigation and the application of information theory to aesthetics is restricted to the formal properties of a work of art.

In his information aesthetic, Bense introduced the idea of macro- and micro-aesthetics: “Macro-aesthetics is concerned with the evident realms of perceptions of the

aesthetic object, micro-aesthetics with the not-evident realms of the aesthetic object” (Walther, 2000). The micro-aesthetic includes not only the un-perceivable structural relations of elements, but also the a-perceptual elements such as the relationship between theory and the work (Gianetti, 2004). As such, Bense’s theory deals with ‘pure’ information as well as with aesthetic information of a physical nature, but whereas Moles and Attneave were writing principally for scientists, Bense was writing for artists. Accordingly, the concept of micro-aesthetics has greater potential application in art practice than for an empirical investigation, and it is discussed further in the next part of this chapter on visual complexity in aesthetic practice.

Attneave (1954, p.189) employs information theory concepts to describe perception as a process of “economical description”, analogous to data compression, in which redundant visual information is discarded. In the case of random and chaotic images, we reduce their structural detail (what Bense might call micro-aesthetic information) and perceive a kind of overall texture (macro-aesthetic) as an economical description of sensory visual information:

Perception might be conceived as a set of preliminary “data-reduction” operations, whereby sensory information is described, or encoded, in a form more economical than that in which it impinges on the receptors. (Attneave, 1959a, p.82)

This is an explicit application of concepts from information theory to psychological phenomena, but at this stage in the field these are hypotheses that lack empirical support. The value of the ideas is that they not only suggest mechanisms of perception but also “the types of measurement which are likely to prove appropriate in the quantitative psychophysical study of complex perceptual processes” (Attneave, 1954, p.192). The type of measurement Attneave proposes is based on an informational scale.

### **Visual Order and Randomness**

To explore the visual scale of order–randomness, Attneave (1959b) created patterns with *stochastic* (non-deterministic, i.e. random) processes: Starting with a blank grid, a coin is

flipped to decide whether to generate an upward- or downward-sloping diagonal line to fill each square in the grid. This random image is then used as a basic repeating unit to form a regular pattern. The repeating unit can be altered by randomly changing some of its elements as it is repeated, which generates an overall pattern with random deviations from the regular repetitive pattern. Information theory allows us to quantify the regularity or randomness of the resulting patterns. The question Attneave was exploring was how much randomness has to be introduced into the repeating pattern before it is no longer perceived as regular. Figure 25 illustrates four images generated with this method, and we can see that with only 15 per cent randomness it is already difficult to identify the underlying regular pattern. Attneave's hypothesis was that most people would prefer slightly irregular patterns to completely regular ones (1959b, p.505), but unfortunately this was not tested experimentally.

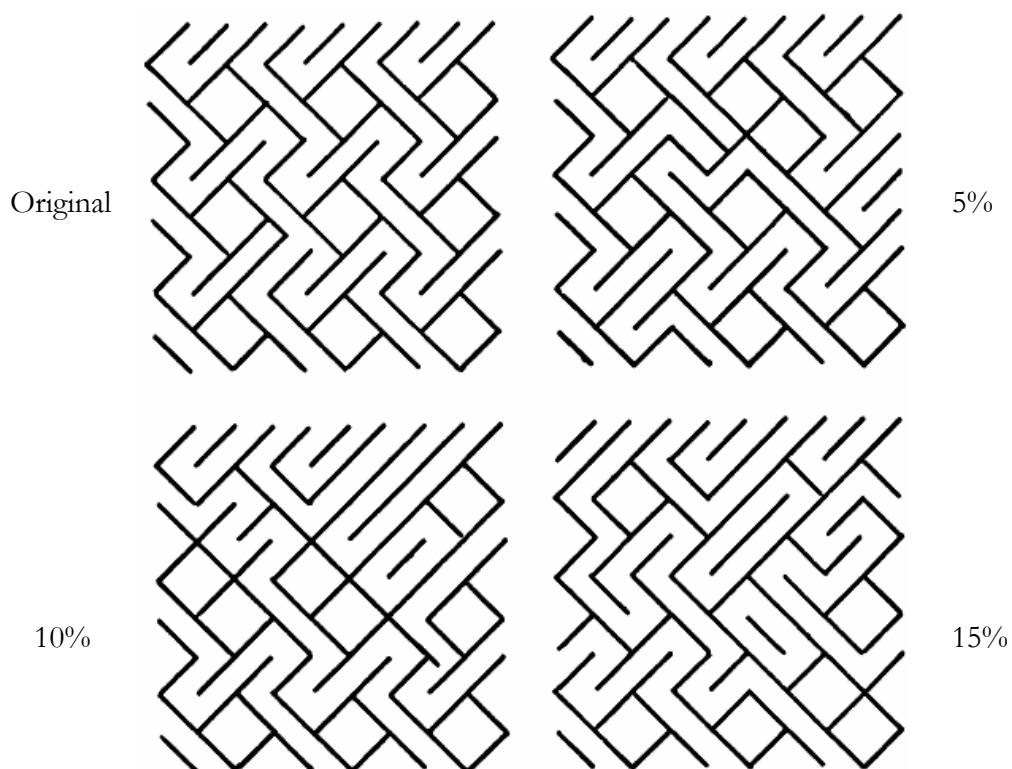

Figure 25 Stochastic pattern composition (Attneave, 1959b). A repeating unit is composed of a 3x3 grid of random diagonal lines, which is itself repeated 3x3 to form a regular pattern (top left). Parts of the unit are altered in each repeat to give patterns with 5, 10 and 15 % random deviation from the original pattern.

Another early contribution to the field of informational aesthetics was made by Wilhelm Fucks, who had conducted research on the mathematical analysis of style (1952) which predated the advent of information theory. Unfortunately, most of the relevant publications by Bense and Fucks are unavailable in English translation, and so they must be omitted from this contextual review. Nevertheless, we may at least glimpse something of Fucks' approach with two images from his book *Exaktwissenschaftliche Musikanalyse* (1965), in which he applied information theory to the analysis of music: Figure 26 shows his mapping of patterns of musical tones from various pieces of orchestral music onto a grid, the dots presumably identifying repeating patterns and correspondences between notes or phrases. What is interesting about these graphics is that although they are the result of analysis rather than synthesis, they display elements of order and randomness comparable to those present in Attneave's stochastic composition processes (Figure 25) and Bridget Riley's dot paintings (Figure 28). If Fucks' analytical images represent a valid mapping of musical structure, then we may infer that a similar aesthetic of order and randomness is involved in musical composition as it is in visual art. From the standpoint of visual art, it is intriguing that what may sound like rather dry scientific and information-based analyses furnish such appealing images as those produced by Attneave and Fucks. The correspondence of musical and visual aesthetic structure also suggests the possibility of a universal information aesthetic that may reach across creative disciplines and artistic media.



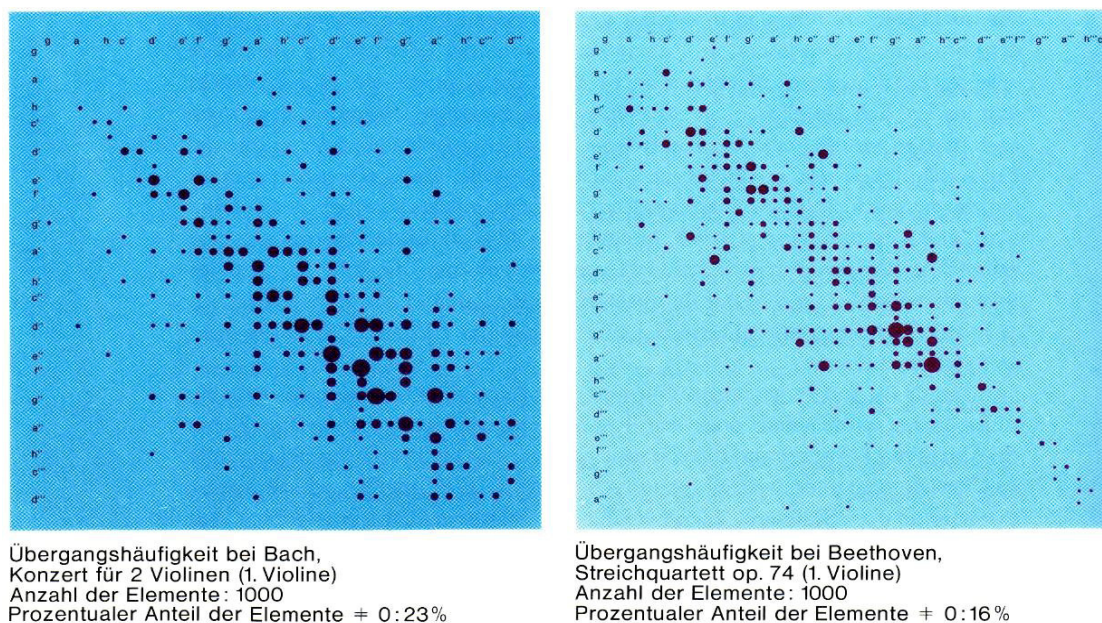

Figure 26 Wilhelm Fucks. Images from *Exaktwissenschaftliche Musikanalyse* (1965).

## The Influence of the Computer

The advantage of the informational approach is that it allows for precise measurement. The problem with the approach is that the amount of visual information in artworks makes this measurement difficult. Arnheim put it like this:

The problem at hand can be approached also from the other end. Instead of analyzing simple groups of elements, one can start with the peculiar patterns we call works of art and ask what kind of information they furnish. [...] Can a theory fitted to the respectable objectives of engineering cope with such mavericks? (1959b, p.503)

This problem is not surprising, since we have learnt that complexity is associated with difficulty of description and that artworks are visually complex. In this situation, it is therefore natural to approach the problem by dealing with relatively simple stimuli which are easy to make and measure. Before the advent of computing, this seemed to be the only option for empirical investigations of visual complexity. The computer solves the problem by speeding-up the process of making and measuring stimuli. For example, the images in Figure 25 that Attneave said were “extremely laborious” to create by hand through stochastic composition processes (1959b, p.506) I managed to reproduce in around ten minutes by writing a *Mathematica* program that took only a few seconds to generate images.

Figure 27 shows an image I made based on Attneave's stochastic procedure, with a thousand diagonal elements and 100 per cent randomness. The image also demonstrates the property, noted by Attneave, that randomness is perceived as an overall texture.

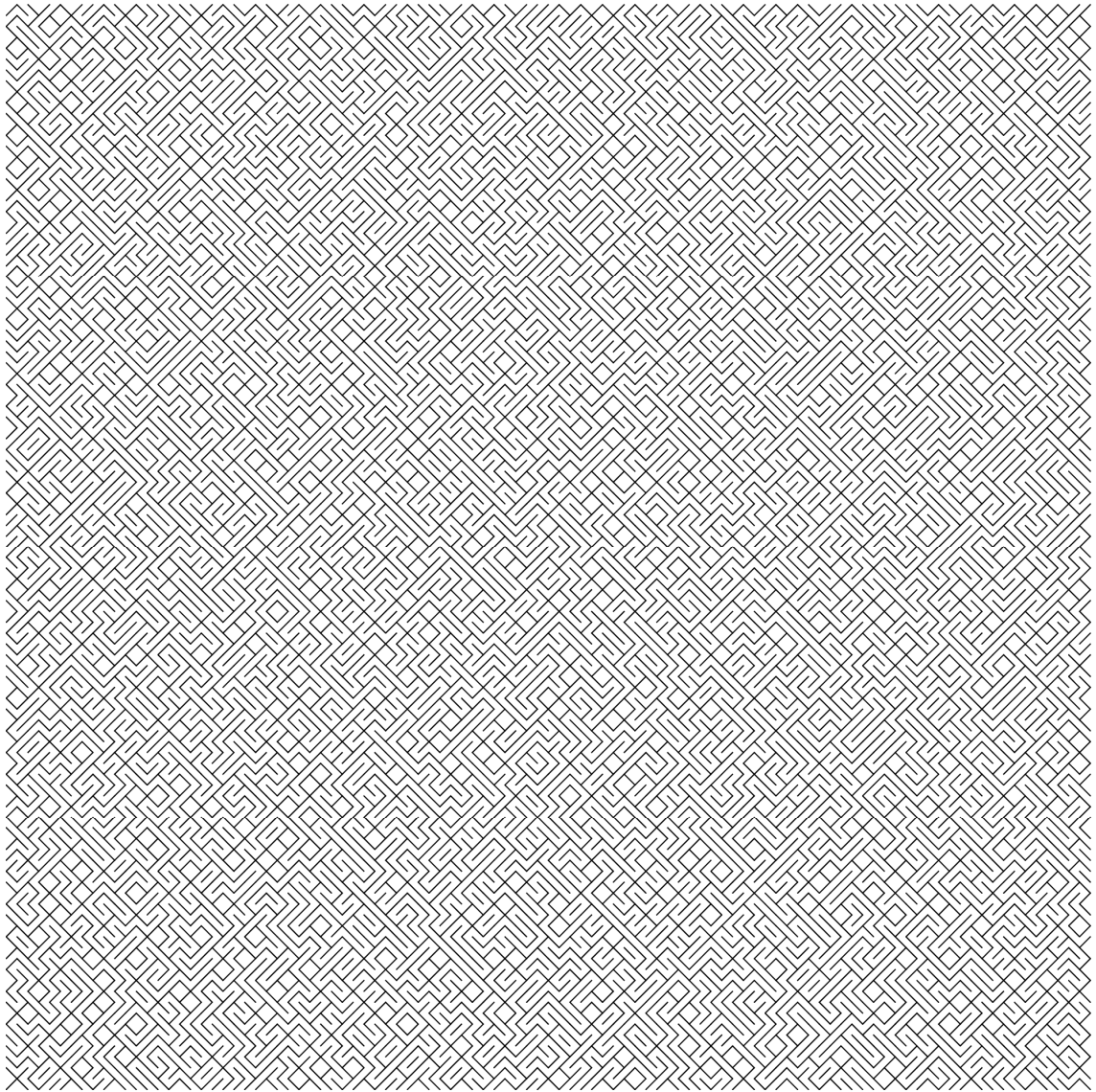

Figure 27 A 100x100 grid of randomly-selected diagonal elements.

A more recent investigation into the role of order and randomness was undertaken by Neil Dodgson (2008) who, unlike Attneave, had the benefit of using a computer. Dodgson investigated the visual structure of Bridget Riley's early op-art. Unlike some of Riley's more familiar regular patterns, these pictures contain apparently random elements as well as order (Figure 28). Without knowing the particular technique employed by Riley,

Dodgson attempted to recreate her work by using computer algorithms to generate similar types of images. The algorithms produced regular patterns with random deviations, and the proportion of this randomness was manipulated.



Figure 28 Bridget Riley (1965) *Fragment 6/9*. Screenprint on Perspex, 625 × 721 mm.

By combining order and randomness in a computational process, Dodgson was able to recreate the aesthetic properties of Riley’s artwork, and to generate appealing visual complexity. The images that were closest to the original artworks resulted from an algorithm in which about one third of the picture elements in a regular pattern were randomly added, moved or deleted, such that the images contained two thirds order and one third randomness. I agree with Dodgson’s conclusion:

The particular examples examined here have introduced very limited randomness and yet even this limited randomness provides a great deal of complexity. This is a tribute to the pattern-detection systems in the human brain. (2008, p.122)

Dodgson attributes the perception of complexity to a perceptual process of pattern-detection. Pattern-detection is how we recognise order, complexity, and randomness – all of which are kinds of pattern. The formal constraints with which Dodgson structures his

images also limit the perceptual grouping of picture elements and thus the type of pattern we might perceive. For example, in a regular chequered pattern of black and white squares, we would likely perceive only regular perpendicular and diagonal structures. Disrupting this regularity by introducing randomness opens up a pattern to alternative perceptual groupings. The implication from Attneave (1959b) is that introducing more randomness increases perceived complexity only up to a point, beyond which images just appear random. In other words, the findings of Attneave and Dodgson imply the existence of a threshold to the perception of complexity in relation to an informational measure of complexity. This threshold we identified in Chapter 1 (p.45) as also being proposed by Wolfram (2002, p.559) and Donderi (2006b, pp.87–88).

Possible explanations for visual pattern-detection include the Gestalt principles of grouping – such as those of figure/ground, similarity, proximity, and symmetry (Bruce, Green & Georgeson, 2003) – and Richard Gregory’s (1980) theory of “perceptions as hypotheses”. The Gestalt approach could be called ‘bottom-up’ because it describes perceived forms as emerging from constituent units, whereas Gregory’s approach is more ‘top-down’ since it depends on cognitive hypotheses based on prior experience. The first significant point following from Attneave’s results, however, is that an image becomes more interesting when the number of possible ‘groupings’ or ‘hypotheses’ is increased. The second point is that this visual interestingness can be promoted by the combination of order and randomness, which gives rise to the perception of visual complexity. The most complex image in Dodgson’s paper (also the image that I find most appealing) is the one that illustrates the transformations required to get from the regular underlying pattern to the final version (Figure 29). The added colours and shapes increase the variety of elements and increase the visual complexity of the image. The arrows and crosses invite a visual exploration, especially when seen in the context of the original and underlying patterns.

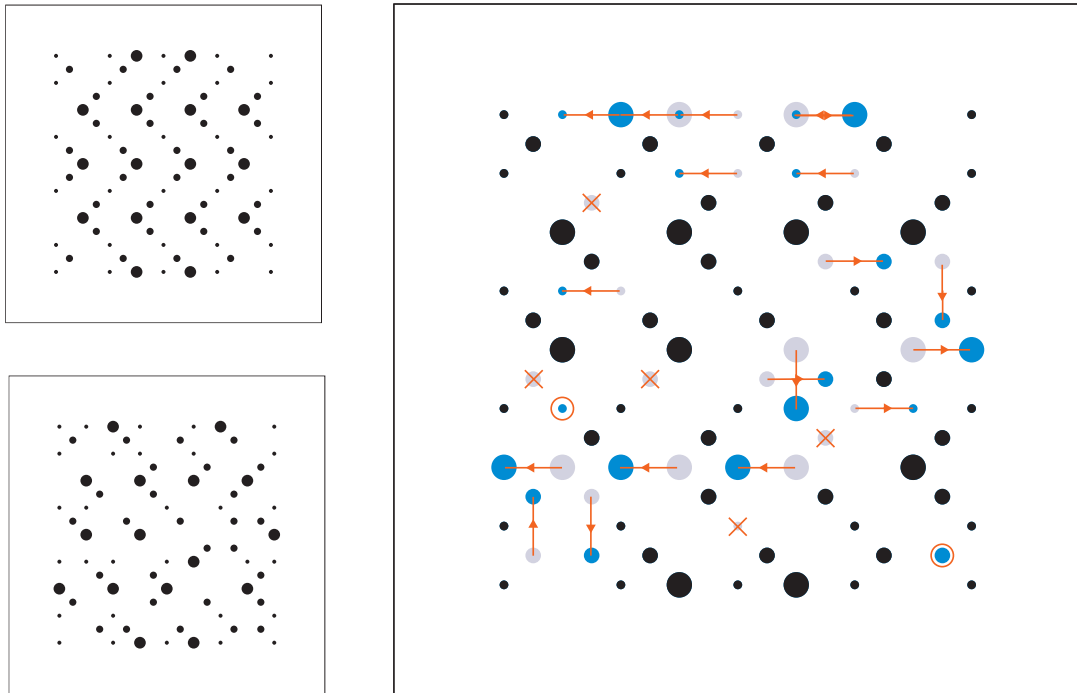

Figure 29 How to get from simple order to complexity by introducing randomness. The larger image shows how to transform the underlying regular pattern (top left) to a representation of Riley’s *Fragments 6/4* (bottom left), by moving, adding and deleting picture elements. (Dodgson, 2008)

### The Computational Approach to Visual Perception

After the breakthrough of understanding visual properties in terms of quantifiable information, the next logical step is to understand the process of perception in terms of the computation of this information. David Marr (1982) describes vision as a “complex information-processing system”, whose purpose is to reveal “what is present in the world, and where it is” (p.3). We know that the input to this process is a two-dimensional visual array (light entering the retina) and that the output is perception of the three-dimensional world. The problem for the science of perception is: how does it work? In Marr’s approach, this formidable problem is divided into separate problems of understanding the *computation* (what the system does with the array of visual information, and why), the *algorithm* (how those computations are tackled) and the *implementation* (the mechanism or ‘hardware’) involved in visual processing. The theory attempts to explain how a visual array is processed to give a two-dimensional ‘primal sketch’ of a scene composed of visual

primitives such as edges, lines and blobs, and how these primitives are further processed into a '2½D-sketch' which includes an indication of depth relative to the observer, and then into recognizable 3D objects and scenes.

Support for Marr's theory comes from neurophysiology and psychophysics, as follows: The primitives that compose the 2½D-sketch are mainly processed in the retina. David Hubel and Torsten Wiesel (1962) identified that the outputs of photoreceptors (rods and cones) in the retina are linked together to form *receptive fields*. In the visual system, a receptive field is a group of photoreceptor cells in the retina that acts as an information-processing unit. The way in which the receptors are connected defines a small cluster which is divided into a centre and surround. One type of receptive field responds to stimulation in the centre, whilst in another type the same stimulus inhibits its response. In general, receptive fields give a lower response for overall stimulation, and respond most strongly when only one part (either the centre or the surround) is stimulated. This happens when an edge is perceived, because a perceived edge is a relative difference in light intensity (Marr reserves the word 'edge' for perceptual phenomena and 'intensity gradient' for the physical equivalent). Because this process occurs in the retina, the recognition of 'edges' (i.e. adjacent light and dark areas) functions at a pre-conscious level of perception (Snowden, Thompson, and Troscianko, 2006). The operation of receptive fields has a direct bearing on the amount of detail we can perceive: smaller and more densely-packed receptive fields enable the perception of finer detail. As with Marr's distinction between 'edges' and 'intensity gradients', 'detail' is the perceptual equivalent of what is known as *spatial frequency*, which is defined as the number of cycles (e.g. light and dark stripes) per degree of visual angle (Bruce, Green & Georgeson, 2003).

Naturally, the computational approach involves a mathematical representation of these processes and the use of computers to carry out the kind of laborious tasks that visual processing requires, but what allows for this is the separability of the levels of description. For example: if, instead of perceiving light intensity, the computational task is

to add numbers together, it makes no difference to the result whether we use decimal or binary systems to represent the numbers, whether the choice of algorithm is efficient, nor whether the calculation is implemented mentally or with an abacus or a computer. Similarly, light levels and colours can be represented by neurochemical signals or binary digits. Separating the problems frees up investigation to explore the most salient features because at certain levels of description some computations are equivalent. For example,  $2 + 2 = 4$  is equally true whether performed in the brain or on a computer. In this way, the computational approach justifies the use of information technology as an investigative tool for visual perception. Computational models based on this approach can be tested empirically against human biology and psychology to determine how accurate and useful they are. For instance, Marr & Hildreth's (1980) algorithm, which was designed to model the edge-detection process of receptive fields in the retina, has been found wanting as a biological theory, but is now used in machine vision and in image-processing software such as *Photoshop*, as illustrated in Figure 30.

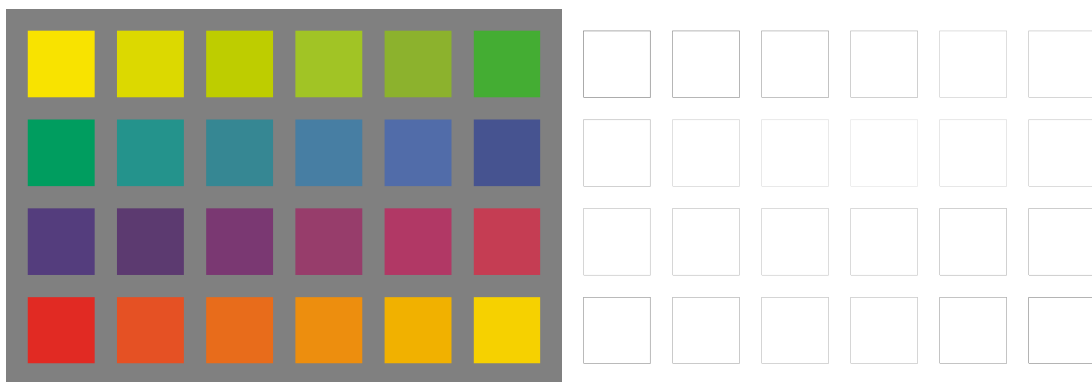

Figure 30 Edge-detection in image processing: before (left) and after (right).

Marr's separation of the visual processes and subsequent identification of the edge-detection algorithm means that the computation of these receptive fields can be modelled on computers. Its effect on digital images illustrates the identification of edges and lines from a visual array; a stronger edge is more visible when contrast is greatest, as seen in Figure 30, which was created by using a convolution algorithm similar to Marr's (the Laplacian-of-Gaussian operator). The strongest edges appear to lie on the borders of the

lightest and darkest colour patches, and the weakest edges are next to the colours that are closest in tone to the mid-grey background. The resulting greyscale image also represents the fact that edge-detection is a process independent of colour perception – it only depends on light intensity.

If we accept Marr’s ‘sketch’ theory, the implication is that the perception of visual complexity is a function of these visual primitives. More primitives and more types of primitives make for greater visual complexity. We have already identified the quantity, variety and order of picture elements as significant objective properties of visual complexity; now with Marr’s visual primitives we have identified significant subjective picture elements: Edges, lines and blobs are the basic perceivable forms, which are further distinguished by tone and colour.

Zeki and Lamb (1994) describe the perception of motion in terms of receptive fields in the visual cortex area of the brain. Like those in the retina, these receptive fields are also areas in which stimulation of multiple receptors combine to affect the response of a single neuron. According to Zeki and Lamb (1994, p.613), artworks stimulate motion-sensitive receptive fields in various ways. For example, the static representations of motion in the Futurist paintings of Duchamp and Jean Tinguely stimulate different regions to those activated by Alexander Calder’s mobiles. Zeki’s ‘neuroaesthetics’ research explores the psychophysical relation of visual art to neural activity. By understanding the perceptual effects of art in terms of brain function, Zeki postulates that “the artist is, in a sense, a neuroscientist, exploring the potentials and capacities of the brain, though with different tools” (2009). The conclusion is that because kinetic art activates certain neural responses, the artist who makes this artwork exploits the response and intuitively explores the structural function of the brain. Whether this neuroaesthetic approach is the *only* way in which we can fully understand how artworks give rise to aesthetic experiences, as Zeki maintains, appears to be open to question. The focus and methods of Zeki’s research are beyond the scope of the current project, but the modelling of perceptual processes enabled



by Marr's computational approach to vision has potential application for empirical studies of visual complexity, as we see in the following section. The strength of Marr's theory is that its separation of the problems allows for the modelling and analysis of perception. Furthermore, its separation of the processes justifies the computational modelling and analysis of aesthetics by incorporating the concepts of computation and information into a theoretical framework of visual perception.

## **Aesthetic Measures**

We noted previously that perceptions can be measured with various psychological techniques such as magnitude estimation scaling (MES). MES provides a general method that can be applied to a variety of subjective perceptions, including visual complexity. In the following section we examine some of the contemporary techniques employed in the measurement of objective and subjective visual complexity, with a view to identifying the appropriate research methods for the current project. The potential of these methods for the project is evaluated principally in terms of their ability to cope with images of art and design and the strength of their correlation with human perception.

### **Eye-Tracking**

Miall & Tchalenko studied artist's movements during portrait drawing (2001) and eye-hand coordination strategies in copying complex lines (2008). Equipment tracked the direction of the participants' gaze whilst drawing, and revealed different patterns of drawing strategies in the temporal cycles of looking in turn at the original and the copied drawing. Besides eye-tracking, Paul Locher (2003) explored various experimental methods to assess the contribution of pictorial balance in aesthetic perception of visual art. Locher's results show that balanced pictorial arrangements attract more fixation on the surface than unbalanced arrangements, and confirm that pictorial balance is a significant factor in the creation and perception of visual art.

The eye-tracking technique does not constitute a measure of complexity as such, but the quantitative nature of the data it furnishes suggests that some form of informational

measure could in theory be applied. In general, it seems that a more complex image invites a more complex perceptual exploration as described by the patterns of gaze-fixation identified by eye-tracking. It would be interesting to determine the correlation between the complexity of the sequence of actions and the visual complexity of the resulting images. Certainly, it takes more time to create a complex oil painting than a simpler charcoal sketch, and a greater variety of movements are performed in the process of painting with oils. Overall, though, despite its relative simplicity and practicality, the eye-tracking method is only an indirect measure of visual complexity, and may not be the most appropriate technique for the present study.

### **Aesthetic Preference**

There have been numerous studies of preference for various types of visual stimuli, including many based on the experimental framework of Berlyne (1971) discussed earlier. Prominent researchers in the field include Colin Martindale and Paul Locher, each of whom has served as president of the International Association for Empirical Aesthetics. Both authors have employed an information-based approach to aesthetic measurement in relation to the preference for complex images.

Martindale, Moore & Borkum (1990) carried out experiments based on Berlyne's theory that aesthetic preference is a function of hedonic arousal. The authors identify the influence of Berlyne's aesthetic theory in the number of citations of his work from three international conferences on experimental aesthetics: Berlyne is the most-cited author, appearing in 39% of the conference papers, followed by Arnheim and Gibson with 15% each (Martindale, Moore & Borkum, 1990, p.53). Martindale and colleague's experiments aimed to test the predictions of Berlyne's theory, such as the prediction that the collative variables – including visual complexity – are amongst the most significant determinants of aesthetic preference. The first of these experiments focused on random polygons as visual stimuli, and complexity was measured in terms of the number of 'turns' (corners) present in the shapes. Their results were overwhelmingly negative for Berlyne's predictions,

showing that semantic information is more influential than the collative properties in predicting aesthetic preference. These results were validated in further experiments which used representational drawings and paintings as stimuli. However, when the experiments included images of both representative and abstract artworks in addition to random polygons, the result is that complexity is a better predictor of preference (Martindale *et al.*, 1990, p.73).

Martindale and colleagues (1990) found that their results were not affected by knowledge of art. Participants' art knowledge was measured by indicating how much they knew about "art in general" on a numerical scale ranging from "a lot" (1) to "nothing" (7). Locher, Smith and Smith (2001) also investigated the role of art experience in the aesthetic judgement of visual stimuli. The stimuli included original paintings by Rembrandt, Breugel and Vermeer from the New York Metropolitan Museum of Art, and reproductions of those artworks in the format of digital images and projected slides. The results show that ratings of aesthetic qualities were similar for both art-trained and untrained viewers, and that the ratings were comparable for both original images and reproductions. The authors name this indifference to stimulus format 'facsimile accommodation', and their results provide experimental evidence of the comparability of aesthetic evaluation between these diverse conditions. It suggests that although the originals were judged to be slightly more interesting and pleasing, the effect of reproduction may not be as significant as expected on the judgement of aesthetic properties, including visual complexity.

Marcos Roberts (2007) investigated the divergent experimental evidence for Berlyne's (1971) inverted 'U' shape correlation between complexity and preference, following on from Martindale's (1990) challenge to the theory. Unlike the experiments of Martindale and Locher, Roberts' methods were based solely on subjective estimates of complexity rather than objective measures. Digital reproductions of artworks of a variety of styles including abstract and representational artwork were used as stimuli. From the results, Roberts identified that the most significant factors of visual complexity are: a) the

amount and variety of picture elements, b) the organization of elements, and c) the asymmetry of the elements.

### **Edge Detection**

Experimental psychologists have employed Marr's theoretical framework and used edge-detection algorithms to measure visual complexity. Forsythe, Sheehy and Sawey (2003) investigate various measures of graphic icon complexity as a way of finding an easier method than survey and questionnaire techniques. Of six tested aesthetic measures, the strongest correlations are with "structural variability" ( $r = 0.65, p < 0.008$ ) and "edge information" ( $r = 0.64$ ). The conclusion is that these computational measures match perceived complexity closely enough to offer a workable alternative to the costly and time-consuming surveys of icon design (2003, p.341). Forsythe (2008) uses various image-processing methods, including edge-detection algorithms, to examine the influence of image familiarity on judgements of visual complexity. The analysis reveals a familiarity bias in estimates of visual complexity: participants tested over a week already showed that their familiarity with images affected their reported perceptions of visual complexity. The explanation for this bias is that "when observers are asked to consider the complexity of an image, they also process task-irrelevant information, such as its familiarity and meaningfulness" (Forsythe 2008, p.124). Forsythe proposes the computational edge detection technique as an alternative to perceived complexity that is less susceptible to bias.

The findings support the idea that a complex image is one with many edges, Processing edges takes time, and mainly happens prior to semantic processing: "Regardless of experience, a more detailed object will take longer to reach semantic processing, because the preprocessing of many edges is perceptually demanding" (Forsythe *et al.*, 2003, p.341). 'Perceptually demanding' means that it is a difficult and complicated process which takes time and effort to achieve. This substantiates the connection between the number of edges in an image and its visual complexity, which we have understood as being related to the difficulty of description or execution. Weaknesses of this measure in regard to the aesthetic

perception of art include the fact that it disregards colour information and focuses only on tonal variation. However, since perceptual edge-detection also operates before colour processing and has been shown to be a significant factor in the construction of sensory percepts (Marr, 1982), this criticism of the measure may be offset with evidence of its correlation with human perception.

### **Fractal Measures**

As well as a noun, the word ‘fractal’ is an adjective which describes the intricacy of these self-similar shapes. This intricacy is known as its fractal dimension. For example, a fractal line that almost fills a two-dimensional surface has a fractal dimension greater than one but less than two. Another fractal line that is even more intricate covers more of the surface and has a higher fractal dimension. Ordinary Euclidean shapes – such as squares and circles – have a fractal dimension equal to their topological dimension, which is always a whole number (a line = 1, square = 2, cube = 3, etc.). Mandelbrot (1982) defined fractals as the shapes for which their fractal dimension is not equal to their topological dimension but is a fraction of that number (technically, when the Hausdorff-Besicovitch dimension exceeds the topological dimension). Therefore, we can understand the meaning of the adjective ‘fractal’ as ‘fractional dimension’, and we can use it as a measure of complexity.

There are a variety of measures that capture this property, and a number of them have been used to quantify the visual complexity of stimuli in aesthetic experiments. For example, Julien Sprott (1994) employed two measures, fractal correlation dimension and the Lyapunov exponent, to quantify the visual complexity of images. Sprott used iterated function systems (IFS) to generate stimulus images of strange attractors, which are fractal shapes in phase space (such as the Lorenz attractor in Figure 13). The Lyapunov exponent measures the unpredictability of the dynamic process that generates the image (in this case, an IFS). It measures the rate at which two adjacent points diverge in phase-space (somewhat like measuring divergence of points on the Lorenz attractor, or the divergent paths of the leaves that I dropped in a stream to demonstrate the effects of chaos). Sprott

generated 7500 fractal images and graded them according to his own aesthetic evaluation on a five-point scale. He found a correlation between fractal measures and aesthetic rating: the highest-rated images had also had the largest fractal values (Lyapunov exponent = -0.24 and a fractal dimension = 1.5).

Aks and Spratt (1996) performed a similar investigation, this time with a group of test participants instead of the author's aesthetic evaluation. These tests measured the fractal dimension ( $F$ ) space-filling of the shapes, and the Lyapunov exponent ( $L$ ). With 24 undergraduate students from art and science courses, the result was that the most preferred images had values of  $F = 1.26$ , and  $L = 0.37$ . The authors claim that these values are close to those found in natural objects, such as the coastline of Britain, which has a fractal dimension of 1.25 (Aks & Spratt, 1996, p.2). A similar preference for images with fractal values close to natural forms is reported by Taylor *et al.* (2003), who investigated the aesthetic response to natural, artificial and hand-made fractals. Using a variety of these stimuli with a range of fractal dimension between 1.1 and 1.9, the participants' task was to state which of a pair of images of differing fractal values was the most "visually appealing" (2003, p.95). The results indicate a grouping of fractal values across all three types of image: low preference for the lowest (1.1–1.3) and highest (1.5–1.9) fractal values, and high preference for middle range of values (1.3–1.5). Further support for this preference comes from Hagerhall *et al.* (2008), who studied the neurological response to viewing a range of fractal images. With electroencephalogram (EEG) monitoring, Hagerhall found that

Patterns with a fractal dimension of 1.3 elicited the most interesting EEG, with the highest alpha in the frontal lobes but also the highest beta in the parietal area, pointing to a complicated interplay between different parts of the brain when experiencing this pattern. (Hagerhall *et al.*, 2008, p.1488).

While the results of these three experiments support the idea that medium complexity fractal images are the most aesthetically pleasing, it also appears to question the suggestion by Aks and Spratt (1996) that the explanation is a connection to *natural* fractal forms. The problem is that natural fractals can be found over the entire range of fractal

dimensions. For example, Taylor *et al.* (2003) collated measures of natural fractals from a variety of sources that evidence a range from as low as 1.1 in coastlines up to 1.9 in plants (2003, p.92), and their experiments included samples covering this range.<sup>7</sup> Overall, the findings of these experiments accord with Fechner's principle of the aesthetic middle and Berlyne's (1971) framework of aesthetic preference for stimuli of medium intensity.

In a follow-up to their earlier experiment, Aks and Sprott (1996) investigate whether the creative ability of participants affects preference for fractal values of the images. They suggest that "scientists may tend to see beauty in simplicity whereas artists may be more tolerant of complexity" (1996, p.9). Fifteen of the participants from the previous experiment were assessed for creative ability with a questionnaire and grouped according to whether their creativity was above or below the mean. Apart from a marginal preference for detail amongst self-rated 'divergent thinkers', the analysis shows no significant difference in preference between the groups, possibly due to the small sample size of participants. These results suggest that self-reported creativity is a poor indicator of aesthetic preference.

Few empirical studies of fractal aesthetics have utilised artworks as stimuli. The reason is likely that fractal measures are of little use for non-fractal images, and that fractal artworks are relatively scarce. However, there is one artwork that offers a large collection of fractal material for investigation: Scott Draves' (2009) *Electric Sheep* project (which is discussed further in the section on art practice). *Electric Sheep* is an interactive online screensaver in which users can vote for their preference of animated fractals (called 'sheep') by pressing the up or down arrow key to indicate like or dislike of the current image. Votes are collated in a central server which deletes the least popular sheep and picks out pairs of the most popular ones to produce a new animation by combining the parameters of the parents using a genetic algorithm. Users can also design their own sheep and upload them

---

<sup>7</sup> Since these experiments examine two-dimensional images, the range of fractal dimension is restricted to between 1 and 2.

to the server, so a new ‘flock’ consists of a mixture of computer-generated and human-designed animations, all of which are then subjected to the voting and culling/breeding process. In its operation, therefore, *Electric Sheep* accumulates aesthetic preference into its generative processes and provides a large resource for empirical investigation. A study conducted by Draves *et al.* (2008) is based on the aesthetic judgements of 20,000 participants on 6,400 images. In the study, preference displayed an inverted ‘U’ correlation with fractal dimension, with a peak around 1.5. Once again, this reinforces the finding of preference for mid-value fractals, though somewhat higher than previous results.

Taylor, Micolich and Jonas (2002) find that Jackson Pollock’s drip paintings are fractal. This may seem surprising when we consider the chaos in the drip technique and the resulting appearance of disorder in the paintings, but measurements indicate fractal dimensions in the range 1.3–1.9. Images of the drip paintings are used in Taylor *et al.*’s (2003) study to represent the category of human-made fractals. In a study of abstract expressionist art, Mureika, Cupchik and Dyer (2004) suggest that the fractal dimension measure is unable to distinguish between different styles. They propose a ‘multifractal’ measure, which offers a more refined statistical measure of self-similarity that is able to make distinctions between styles. The study shows that among expressionist paintings, the work of Pollock is unique in its degree of irregularity and ‘roughness’ of edges (2004, p.56). The authors suggest that the visual system’s propensity for detecting edges – which are so abundant in Pollock’s work – allows for the recognition of order in the chaotic paint drips, and that this is a possible source of their aesthetic appeal.

### **Data Compression**

Beginning with a research project for the Canadian Ministry of Defence into the readability of radar displays and naval charts, Donderi (2000) had the idea of using the data-compression of digital image files as a measure of complexity. In short, the idea is that simple images make small files when compressed, and more complex images make larger compressed files. The argument for this method is that information theory (Shannon &



Weaver, 1948) provides a theoretical basis for the justification of using compression techniques as a measure of visual complexity. As noted in the previous chapter, data compression is a form of the ‘minimum description length’ (MDL) measure of complexity, and MDL is equivalent to the (technically incomputable) ‘algorithmic information content’ (AIC) or ‘Kolmogorov complexity’ measure. Of the various measures of visual complexity discussed thus far, Donderi’s method is the most direct application of an informational scale of measurement. Because data compression algorithms are incorporated into many common digital image file types, this method involves little more than creating an image file with maximum (near-optimum) compression. Therefore data compression offers a simple and efficient objective measure of informational complexity, and it follows that the size of compressed image files is a measure of visual complexity.

The experiments of Donderi & McFadden (2005) provide empirical support for the measure. They show that the difficulty of chart and radar display tasks increases with the size of compressed image files. Since we have understood complexity as being related to difficulty, these results support the method as a measure of visual complexity. Further evidence for the validity of this relationship comes from a second experiment that involved the task of identifying which of two small geometric shapes were present in aerial images of the earth. The logarithm of compressed JPEG file size corresponds with the difficulty of the task as measured by the success in identifying the correct shape. The idea behind the experiment is that a more complex image makes it more difficult to identify the correct shape placed within it. To corroborate this idea, Donderi and McFadden (2005) also measured the subjective complexity of the images with Stevens’ (1975) magnitude estimation method. Eleven participants judged visual complexity by rating 52 images with a number which was in proportion to its perceived complexity. The analysis shows a weak but significant correlation between file size and task accuracy ( $r = 0.14, p < 0.005$ ) and a strong correlation between file size and MES ratings ( $r = 0.77, p < 0.0001$ ). The two

experiments confirm that JPEG file compression corresponds with task difficulty and perceived complexity.

Despite the encouraging results of these experiments, it appears that there may be a problem with the file-compression measure of complexity, which stems from the disparity between information-based measures and perceived or intuitive complexity. In Chapter 1, we noted that randomness is rated highest by informational measures, and that subjective complexity lies somewhere in the middle of an informational scale, between order and randomness (see Figure 16). It implies that the correlation between file size and subjective perceptions of visual complexity may break down for random or near-random images. This problem is summed up as: “Can a display become so ‘complex’ that appears ‘simple?’” (Donderi & McFadden, 2005, p.78). Donderi makes reference to Wolfram’s (2002) observation that the perceived complexity of cellular automata images depends on the identification of patterns. A random image, whilst being rated highly in terms of objective complexity (as measured by file compression or AIC), has no patterns (no redundancy) and so it may appear to be subjectively simple:

We do not know whether, if we study displays with even higher levels of JPEG file complexity, we will begin to see a reduction of perceived complexity and a concomitant change in performance. In short, we do not know where to locate the inflection point that is implied by the Wolfram’s observation about the perceptual simplicity of even more complex visual displays. (Donderi & McFadden, 2005, p.78)

The inflection point that Donderi mentions is the peak of the hypothetical inverted ‘U’ shape correlation between objective and subjective complexity. Before this peak the two measures correlate positively, and beyond it perceptions of complexity decrease as objective complexity increases. Thus the inflection point represents a perceptual threshold of complexity on an informational scale; we are unable to perceive any more complexity. The problem was investigated further by one of Donderi’s research students, Christina Besner (2007), who studied whether the correlation of objective (file size) and subjective (MES) complexity measures would still hold for random images. The stimuli comprised

images of nature scenes, camouflage patterns, and images made by combining two together. Besner conducted two experiments with ten participants each, one with a set of 138 images and the other using 16 from that set. The result is a moderate correlation between file size and estimated complexity ( $r = 0.553, p < 0.001$ ) which becomes stronger when the larger, more random files are ignored ( $r = 0.827, p < 0.001$ ). From this result, Besner draws the conclusion that Donderi's measure remains valid for the images used; the images were not so objectively complex that they appeared to be simple. The result can be interpreted differently, however: As more random images are included, a weaker linear correlation is actually what one might expect to find if the relationship between objective complexity (based on file compression) and perceived complexity (MES) has an inverted 'U' shape. Besner acknowledges that the images were possibly just not random enough to see this effect, which seems a fair assessment given that the stimuli were not generated from random processes.

We have seen that this informational measure of visual complexity does indeed correspond with perceived complexity for images such as radar displays and images of natural scenes. But on the other hand it appears that there are limitations to this method when it comes to images of greater objective complexity, that is, as images approach randomness. Given that we understand images from art and design as being amongst the most complex type of image in subjective terms, we face the following question: Will this objective measure of visual complexity also work for images from art and design? Remarkably, Arnheim had identified much earlier this problem of informational measurement in the arts:

From this reasoning follows what must seem an appalling paradox to any friend of the arts, namely, that complete disorder or chaos provides a maximum of information whereas a completely organized pattern yields no information at all. The friend of the arts, of course, takes the opposite for granted. (Arnheim, 1959, p.501)

With Donderi's file-compression method, we have identified a potentially useful and practicable measure of visual complexity for a study of art and design. We have also

identified the following gaps in knowledge: Firstly, is the relationship between compressed file size and perceived complexity as suggested by Donderi and Wolfram – that is, can we find empirical evidence for a perceptual threshold of visual complexity where the correlation between information content and subjective complexity has an inverted ‘U’ shape? Secondly, will the file-size measure of complexity and its correlation with subjective complexity also work with images from art and design?

## Summary

In this review of empirical aesthetics, we have encountered a variety of approaches. Researchers have variously employed cognitive (Gibson), motivational (Berlyne), Gestalt (Arnheim), and computational (Marr) approaches to visual perception and aesthetics. Amongst these approaches, opinion is divided on whether aesthetic perception differs from everyday perception. Similarly, there are many possible routes to understanding and measuring visual complexity – some intuitive and others more abstract and informational.

Empirical studies of aesthetics can be divided into two categories. What might be called the analytic (or holistic) approach employs real artworks as stimuli, whereas the synthetic (or elementary) approach creates stimuli for testing, such as geometric diagrams, which serve as abstractions of certain features of visual art. Experiments involving genuine artworks as stimuli can be traced back to the work of Fechner, who in 1871 attempted an experiment to record the responses of an audience to two versions of the younger Hans Holbein’s *Madonna with Burgomaster Meyer* (Berlyne, 1971, p.10). Either alternative has problems: The strength of the analytic approach is that it is based on observations of actual artefacts, but these stimuli also have features that might unduly influence the properties under investigation. The selection of stimuli from extant artefacts is thus fraught with difficulties, especially because artworks tend to be held in diverse locations, which may hamper the collection of a representative sample.

The synthetic approach has the benefit of circumventing these practical difficulties in experimentally measuring or controlling the properties of real artworks as stimuli, since the properties of the stimuli can be fully controlled and features of interest can be isolated. The disadvantage of this approach is that it weakens the validity of generalizations that can be made about actual artworks, since the data is based on observations of artificial stimuli in test conditions which are often far removed from the typical gallery experience of visual art. There is reason to believe that Donderi's file-compression measure of visual complexity is able to cope with both artificial stimuli and images of artworks since there is no fundamental difference between the two types of image when reduced to the basic properties of digital image files. The difference between artificial stimuli and actual artworks is, after all, a matter of context, as discussed in the previous section on the aesthetic theories of art. For that reason, the file-compression measure is a strong candidate to be used in the following tests.

## **Aesthetic Practice**

The aim of this section is to identify and examine creative practices that engage with the aesthetics of visual complexity. The scope includes not only practices which manifest complex visual material, but also practices that aim for simplicity of expression. This material includes examples of digital and generative art which explicitly deal with concepts, models and techniques from the sciences of complexity (those which use cellular automata, for example) but these criteria do not constrain the scope of the contextual review. Although the focus is mainly on two-dimensional visual material, some examples of three-dimensional art and sound art are also considered. The choice of material in this section cannot be expected to represent an accurate picture of the full range of today's art practices; rather, the selection is biased towards artworks and artists I have encountered personally and which stimulate my own practice. The examples of art practice are roughly grouped by the complexity of the artwork, and are arranged in order from the simple and regular to the chaotic and random in the following sections.

## Simplicity and Minimalism

It may seem counter-intuitive, but I suggest that minimalism is the art movement that focuses most explicitly on the concept of aesthetic complexity. Donald Judd is regarded as a key figure in the genre, but minimalism is a term he rejected, preferring to describe his work as “the simple expression of a complex thought.” Other artists associated with minimalism rejected the term as a description of their work, despite the outward appearance of reductive strategies in their artwork. Like other minimalists, Judd’s work utilizes simple geometric forms which are often repeated in two- or three-dimensional space. The simplest two-dimensional artwork is the monochrome – a format adopted by artists in a variety of art movements other than minimalism, including Kasimir Malevich, Alexander Rodchenko, Ad Reinhardt, Robert Rauschenberg, Robert Ryman, Yves Klein and Gerhard Richter (Figure 31).

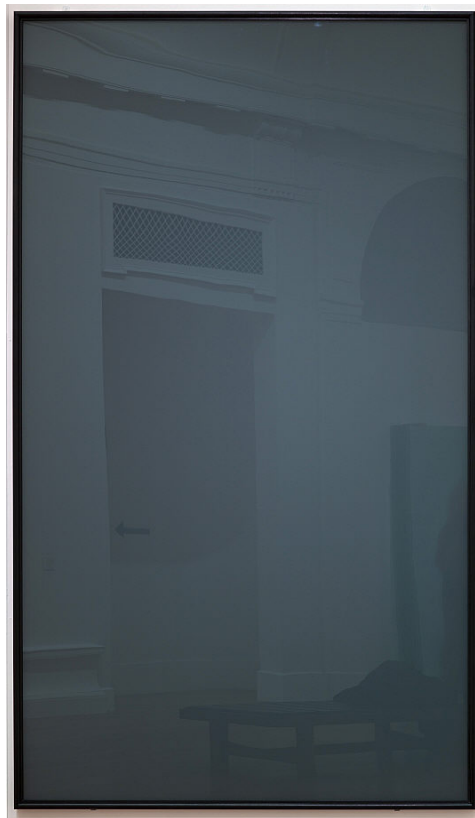

Figure 31 Gerhard Richter, *Grauer Spiegel* (1991), coloured glass, 3000 × 1750 mm.

These artists did not only produce monochromatic works, however, and they were not only interested in what we understand to be the central concerns of minimalism. These

concerns include a 'truth' to materials and a restriction of focus to the internal structure of the artwork without imitation or representation of external reality. In this way, minimalist art claims to be more 'honest' in its lack of illusion and its use of materials that simply speak for themselves and are not subjugated to a role of signification. Reducing illusory distraction and pictorial clutter allows the materials to speak and provides space for us to reflect on the act of perceiving them. So even though its aim is to reduce formal complexity and increase order, minimalism puts the concept of visual complexity at the forefront of its theoretical and aesthetic considerations.

There is an interesting tension between simplicity (as a measure of complexity) and minimalism (as an aesthetic approach), which suggests that we should not assume that the one necessarily follows from the other. Jürgen Schmidhuber's 'low complexity art' uses concepts from algorithmic information theory to create short and simple computer programs. Schmidhuber's stated goal is to create minimally complex programs that generate images that "look right" (1997, p.97). Creating low-complexity algorithmic art is difficult, he says, because we can never be certain that we have found the shortest algorithm for the job. This uncertainty results from the fact that algorithmic complexity (the length of the shortest program that will generate a given pattern) is incomputable. The resulting images are mainly composed of circle segments which combine to create outlines of recognisable shapes, such as butterflies and flowers. Obviously, 'looking right' is highly subjective, and to my eyes the style of Schmidhuber's low-complexity images – which are far from minimalist – is quite repellent. The differences between these examples of low-complexity art demonstrate that aesthetic quality is dependent on more than just the complexity of the artwork.

Minimalist construction is not restricted to visual art and architecture; the movement also flourished in music. One of the simplest musical scores, John Cage's *4'33"* consists of three parts, each with the single instruction *tacet* ('rest'). Despite the simplicity of the piece, the perceived work can be complex since it consists of the ambient sounds present at that

time and location. Through the sounds of the environment, Cage directs perception away from the distractions of ‘music’ towards the act of perception itself, and in doing so he radically reconfigures the possibilities of sound art. Richter’s grey mirrors (Figure 31) perform the same function; their colourless space literally reflects the act of perception, like a visual analogue of the empty music in Cage’s composition. *4’33”* and *Grauer Spiegel* may be perceptually complex, but both are minimal in terms of their composition – we might say that they have low algorithmic complexity. With such minimalist artworks, the audience is expected to contribute their share towards the aesthetic experience. In this sense, though they may be ‘quiet’ (literally or figuratively speaking), minimalist artworks are rarely passive experiences.

Some of the most stimulating work for my own visual art practice discovered during the course of this research has come from music and sound art. In particular, this includes music from the independent record labels Touch (UK), 12k and LINE (USA), and Raster-Noton (Germany). With widely differing styles of music, these labels share a concern for visual and tactile aesthetic quality evident in their minimalist graphic design and packaging. The owners of these labels are active as visual artists – Jon Wozencroft (Touch), Taylor Deupree (12k) and Richard Chartier (LINE) in photography and design; Olaf Bender and Carsten Nicolai (Raster-Noton) in design and art. Design for music packaging has an established history, and these contemporary graphic artists acknowledge the influence of earlier designers such as Peter Saville (Figure 32). Saville’s design for the cover of *Unknown Pleasures* makes it one of the few albums of the time not to feature the artist’s name – an exercise in minimalism that echoes Joy Division’s bleak sound and Martin Hannett’s crisp, sparse production.





Figure 32 Peter Saville and Joy Division, *Unknown Pleasures* (1979).

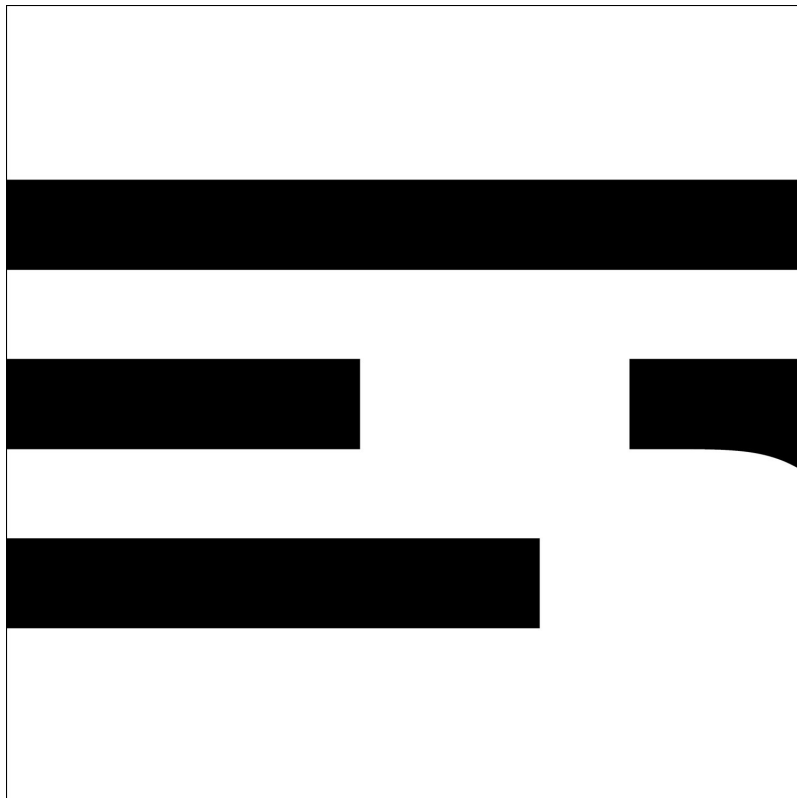

Figure 33 Alva Noto (Carsten Nicolai), *Xerrox Vol.2* (2009).

Raster-Noton has a graphic style of minimal digital futurism which represents its experiments in the “overlapping border areas of pop, art and science”, such as the design of the latest release by Alva Noto (Carsten Nicolai) in Figure 33. As the second volume in a series of five called *Xerrox*, its minimal design represents the letterforms in the corresponding part of its title (ER). In contrast, Touch presents an earthy realism in Wozencroft’s photographs of the British landscape (Figure 34) used, for example, for the environmental recordings of Chris Watson. Both labels share the minimalist concern with honesty in materials – Touch with the images and sounds of the natural world and Raster-Noton with the digital. The 12k aesthetic sits between these two extremes with a “minimalist hybrid of electronic and acoustic music”, incorporating techniques such as field recording and processing of recorded instruments. Figure 35 illustrates Deupree’s album design and the graphic design of its press release. The music by Solo Andata, an Australian duo that uses instruments and field recordings, is typical of the 12k style – soft, melodic drones built up from looped guitar samples and repeating fragments of sound.



Figure 34 Jon Wozencroft, *Willow* (2009).



Figure 35 Taylor Deupree, press release for Solo Andata, *Solo Andata* (2009).

A number of these musicians are also involved in visual art practice and research. For example, Jon Wozencroft currently teaches at the Royal College of Art. The University of York's research group *New Aesthetics in Computer Music* has Mark Fell amongst its staff, and resident artists involved in the project have included Russel Haswell, Olaf Bender, Peter Rehberg and most recently Taylor Deupree. Together with Mat Steel, Mark Fell creates music under the name SND on the Raster-Noton label, although they released their earliest work via the now-defunct record label Mille Plateaux, named after the publication by Deleuze and Guattari (1980). SND's minimal electronic music uses a restricted palette of sounds to create shifting patterns that occupy a strange place between dance music and abstract sound art, popular culture and academicism.

Like some of their contemporaries, SND are often labelled as minimalist, and although it is not always a term with which they are comfortable they do share its concerns. For example, Fell says that he is “not interested in simplicity or minimalism [...] for me this point is more to do with integrity” (Fell, 2009). Deupree does accept the minimalist tag, although more in the sense of ‘economy’ than ‘simplicity’ (Deupree, 2009). The compositional techniques employed by these contemporary musicians can be traced back

to the work of earlier classical minimalists. For example, the *tintinnabuli* (Latin for ‘little bell’) method created by Arvo Pärt, generates permutations of simple triadic chords, often with accompanying drones. Pärt used the technique to achieve simplicity in his minimalist sacred music, such as *Für Alina* (1975): “The complex and many-faceted only confuses me, and I must search for unity” (Morton and Collins, 1992, p.729). Steve Reich used a similar method of combinations of simple repeating rhythms to generate complex musical patterns. Another technique frequently used today is based on the granular synthesis concept of Iannis Xenakis, which transforms sound into small fragments or ‘grains’ that are processed and re-arranged to form new sonic textures. Working with micro-sounds at very small time scales, Xenakis used stochastic processes to create new forms of music that explore the concepts of order and disorder (Matossian, 1986, p.239).

The visual element of SND’s performance at the Transmediale festival 2009 involved “a very simple system that can be described in a couple of sentences, but [which] generates quite complex patterns” (Fell, 2009). As the two musicians operated audio controls for the music, the changing parameters were recorded as coloured lines that built up on a screen behind them, creating an increasingly complex stratified vision of an element of the musical process. Fell said of the project’s computer code that “what we wanted from the system we wrote in two lines – it was really that simple” (Rousset 2009). Robert Henke, developer of the *Ableton Live* music software, and a musician under the name Monolake, says that sonic complexity does not need lots of distinct elements, but that it can also occur with a seemingly simple texture that reveals more detail as the listener pays more attention: “Reduction for me is a trick to guide the listener’s focus to the background where the exciting things are hidden” (Henke, 2009). Henke explains that his background in film music means that he thinks in terms of layers of sound, spatial placement and slight variations of seemingly repetitive elements. This hidden detail, he says, is the type of complexity he finds beautiful:

I would describe it as ‘inherent functional complexity’: It is not the starting point but the result of applying simple processes either on a compositional level or, on a smaller timescale, to the sound creation. Or both of course. The beauty of such a complexity is the amazing discrepancy between the complexity of the result and the [...] simplicity of the process. (Henke, 2009)

Carsten Nicolai describes a similar process in his approach to music creation: “At first you deal with total regularities. I work with measuring systems, with quite a logical background, very simple programs to create distances and really precise sine waves” (Borthwick, 2007). As Alva Noto, Nicolai produces music with pure tones, white noise, and sampled music. “What I do is based on classical compositions and architectural ideas, so for me it is very important to see the sound and to work on it”. The influence of Bense’s concept of information-aesthetics is evident in Nicolai’s precision sculpting of sound in *Mikro Makro* (1996), a collaboration between Nicolai and musician Mika Vainio. The installation comprised two work tables on which were a few objects – lenses, magnifying glasses and electric light bulbs. Nicolai and Vainio composed the music that accompanied the piece, which they later released under the names Noto and Ø respectively. One track contains extreme low and high frequencies combined with pure sine wave tones and bursts of white noise. Despite the obvious digital origin of the music, the auditory experience brings to mind the sounds of bats, whales, birds and waterfalls. Another is based on noise sourced from recordings of pulsars and magnetic resonance imaging. In accord with Bense’s conception of micro-aesthetics as involving elements not directly evident to the senses (Walther, 2000), Nicolai (2009a) says that these micro-elements “point to an existence beyond our realm of perception”. In the same way that the micro-detail of visual randomness or chaos can be perceived as an overall texture, the micro-elements of sound put together in Nicolai’s music are perceived as a texture of drones, hisses and hums. These musical practices are examples of artistic creation through the generation, transformation and combination of simple parts, which demonstrate the minimalist engagement with aesthetic complexity.

## The Grid

A grid is a visual device associated with regularity – a repetition of simple elements. In visual art, the grid is usually presented in two spatial dimensions. A one-dimensional grid in time provides the structure of music and moving image, a three-dimensional grid is a possibility in sculpture, and mathematical or computer modelling can incorporate grids of many more dimensions. In two dimensions, squares, triangles and hexagons appear to be the most common visual elements in human artefacts. Natural grids are formed by collections of similar objects in proximity and are most commonly hexagonal: examples include honeycomb, cells in an onion skin, Rayleigh-Bernard convection cells in heated fluids, and the columnar basalt rock in the Giant’s Causeway, Northern Ireland (originally molten but now solidified convection cells). A recent publication by Carsten Nicolai is a catalogue of grids for graphic design, organised as a spectrum of complexity (Figure 36). *Grid Index* (Nicolai, 2009b) is presented as an

...indexation system that goes from the most basic regular and uniform geometrical tilings to the most complex and irregular ones; a growing array of shapes, vertex transitivity, and symmetry axis present us with an index of plane subdivision possibilities (Nicolai 2009b, no page numbering).

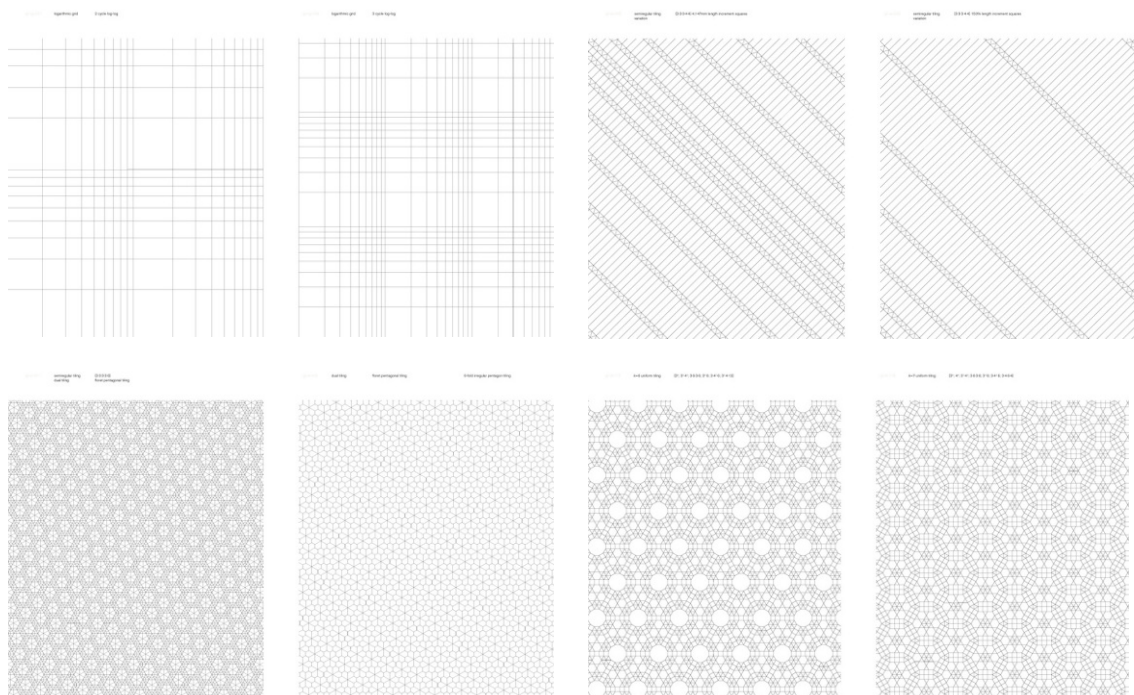

Figure 36 Carsten Nicolai, selection of pages from *Grid Index* (2009).

The content of *Grid Index* is derived from many sources, with a notable amount from Grunbaum and Shephard's mathematical compendium *Tilings and Patterns* (1987) which was one of the first books to publish non-periodic patterns made of regular shapes. Not only does the grid provide a tool for the graphic design of image and text, but also for fine artists and craftspeople. The grid has been the subject of aesthetic investigation and discussion since at least the first mosaics, up to the present discourse by Rosalind Krauss (1985) and James Elkins (2008). Krauss theorizes the grid as a kind of Platonic form relative to nature and art:

Insofar as its order is that of pure relationship, the grid is a way of abrogating the claims of natural objects to have an order particular to themselves; the relationships in the aesthetic field are shown by the grid to be in a world apart and, with respect to natural objects, to be both prior and final. (Krauss, 1985, p.11)

In this sense the grid is also part of the minimalist aesthetic – a simple, self-contained visual structure. Prominent examples of the grid in art include work by the Russian constructivists, Piet Mondrian, Sol LeWitt, Agnes Martin, James Hugonin, Gerhard Richter (Figure 37), and Chuck Close.



Figure 37 Gerhard Richter, *4900 Colours: Version II* (2007), enamel paint on Aludibond, 970 × 970 mm.

Richter's output is interesting in terms of visual complexity because his practice includes work that covers a wide range of complexity. For example, there are works that are simple (the grey series of paintings), regular (colour charts), representational (painted photographic images) and chaotic (abstract multi-coloured paintings). The 'colour chart' series of paintings are the ones that display regular, ordered grid arrangements, but they could also be classified as random or chaotic because there is rarely any apparent pattern in the arrangement of colours. In a variation on the strictly regular grid, Joseph Albers painted the series *Homage to the Square*. Using a limited geometrical vocabulary, Albers explores chromatic and formal relationships to experiment with perceptual effects. Besides the square canvas and the flat shapes, there are also perceivable squares in the lines between areas of colour, present in the same way that a square lined grid is implied between the colours in Richter's colour chart paintings (Figure 37). With the *Homage to the Square* series, Albers demonstrates how visual complexity can arise from a seemingly simple combination of elements.

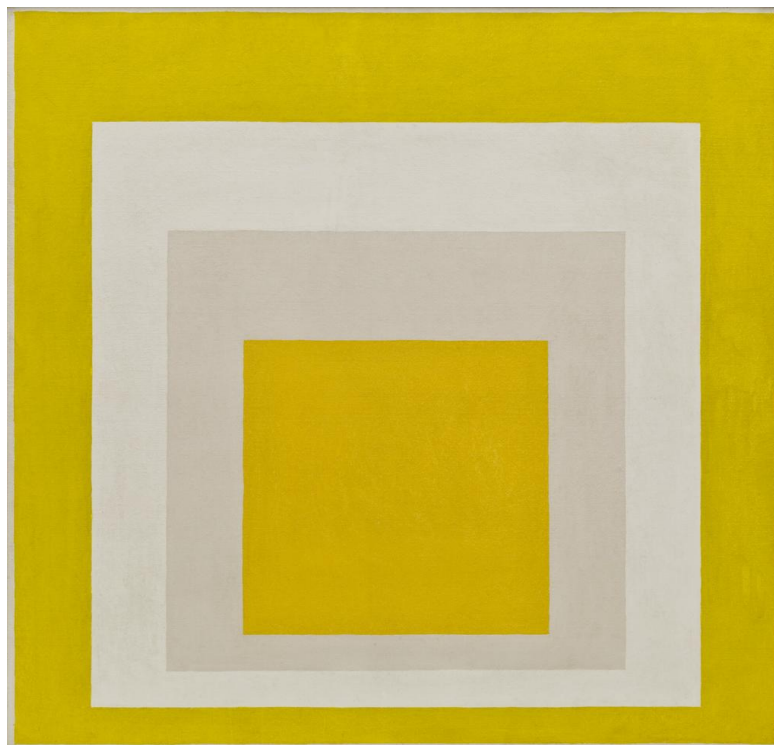

Figure 38 Joseph Albers, *Homage to the Square: Yellow Resonance*, (1957), oil on hardboard, 40 × 40 inches.



One of the most complex grids in visual art can be seen in two sculptures by Gabriel Orozco. The concept was to suspend a whale skeleton in the space and to draw in graphite a three-dimensional grid onto its two-dimensional surface. In 2006, Orozco produced the first of these – *Mobile Matrix*, a commission for the José Vasconcelos Library in Mexico City. A second version of the work inverts the pattern of the grid, resulting in the much heavier-looking *Dark Wave* (Figure 39). The third dimension and the complexity of the surface make drawing this grid a formidable task. Of its construction, Orozco said, “It’s so complex that if you have a bi-dimensional graphic or drawing of a skeleton and then try to map out what you intend to do it...it’s impossible.” (Miller, 2008).

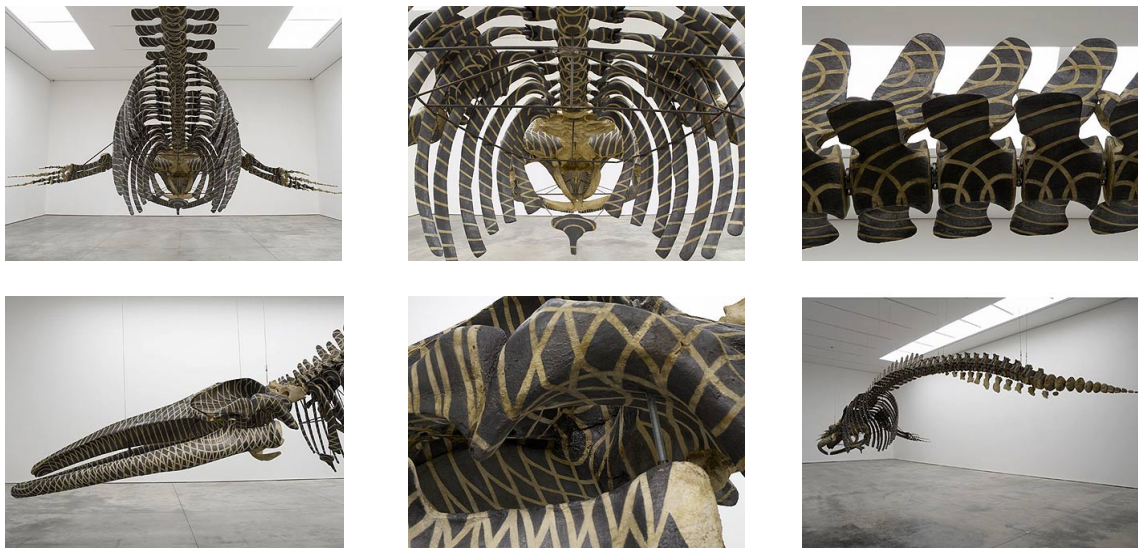

Figure 39 Gabriel Orozco, *Dark Wave* (2006). Whale skeleton and graphite.

## Computer Art

The first computer art exhibitions happened around the same time in Germany and the U.S. In 1965, Bela Julesz and Michael Noll showed *Computer-Generated Pictures* at the Howard Wise Gallery, New York (Dietrich, 1986), and in the same year Frieder Nake, George Nees and A. Michael Noll exhibited their work at the *Studiengalerie* of Stuttgart University (Nake, 2005). A difference between the two exhibitions is that whilst the German exhibitors were practising artists, the two Americans were undertaking scientific research at Bell Laboratories. Julesz’s research for Bell Labs included testing the

randomness of computer-generated number sequences, a job for which he used not a mathematical procedure, but the natural pattern-detection of the human visual system; deviations from randomness (i.e., patches of regular patterns) could be spotted easily when the digit sequences were visualized (Siegel, 2004, p.721).

Frieder Nake describes the computer as a ‘universal picture generator’ (Dietrich, 1986, p.166). Many of the scenes we are able to perceive visually can be captured on digital camera. The image can be stored on computer and shown on screen or printed to give a fair representation of a scene. Images can also be *generated* by the computer, and the number of potential images is enormous. The amount of possible different images with a standard screen resolution of  $1280 \times 1024$  (1,310,720) pixels, using the RGB colour system (16,777,216 colours), is a number with almost ten million digits. To put this number into context, the estimated minimum number of atoms in the observable universe is around  $10^{80}$ , which has only 81 digits. Such a vast space of visual possibilities cannot be explored methodically because of time and computing constraints. What is needed is a way of navigating this space towards the aesthetic ‘hot-spots’ – in other words, an aesthetic rule or algorithm. This is, in effect, the function of algorithmic art like that of the early computer artists – to find rules of composition that model those incorporated into our own aesthetic sensibilities. Just as Dodgson (2008) recreated Riley’s paintings with a computer, Noll also recreated Riley’s artwork. It suggests that Riley was considering these computational elements of information, order and randomness, though without the aid of a computer.

Nake and Nees were taught at Stuttgart by Max Bense, who, together with Abraham Moles, influenced the direction of their work and their acceptance of the computer as a creative tool (Gianetti, 2004). The ‘three Ns’ of computer art – Nake, Nees and Noll – showed their work at Jasia Reichardt’s groundbreaking *Cybernetic Serendipity* exhibition at the Institute of Contemporary Arts, London in 1968. The exhibition and its subsequent publication (*Cybernetics, Art and Ideas*, 1971) dealt with the relationship of the computer and the arts. Figure 40 shows a picture of Bela Julesz, published with his obituary in 2003,

which was taken at his and Noll's exhibition, *Computer-Generated Pictures*. It depicts Julesz in front of one of the artworks, which is unmistakably Attneave's (1959b) stochastic composition process (Figure 25). The evidence in the picture suggests that the early computer artists were aware of the current scientific research. It seems also that Attneave was equally attuned to the arts, since he had foreseen creative potential in the computer for manipulating aesthetic rules rather than just aesthetic properties:

In some respects more appealing than either the imitative or the autonomous computer would be one which allowed the rules of composition to be varied easily and precisely. [...] Such a device would offer extraordinary opportunities for artistic exploration and experimentation. (Attneave, 1959b, p.510)

Attneave also noted that the benefits of this tool would “throw a correspondingly greater burden upon his evaluative or critical capacities”. Moreover, the connection between computer and empirical aesthetics also suggests that we could re-interpret the scientific graphics as a pathfinder in the development of visual culture. James Elkins (2008) sees this kind of value in certain types of scientific visualization, particularly those that are difficult to achieve and which push the boundaries of visualization. To Elkins, this difficulty in making and the resulting improbability of the images lend them aesthetic value.

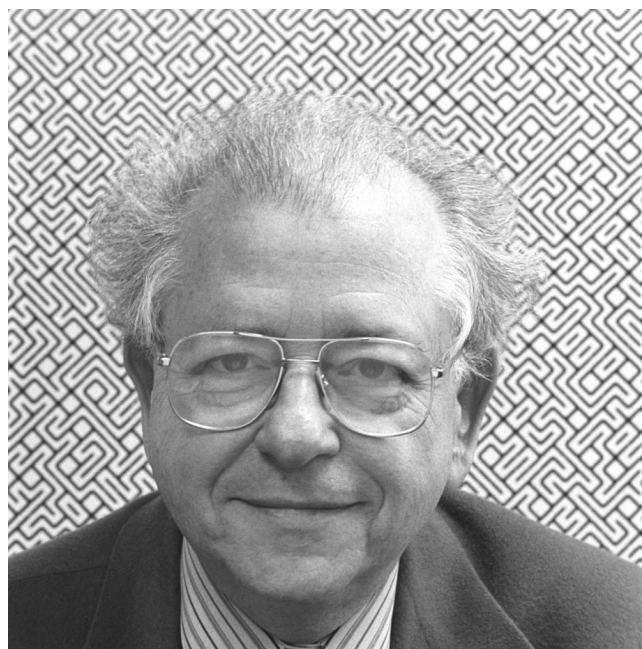

Figure 40 Bela Julesz in 1965, with Attneave's (1959b) *Stochastic Composition Process*.

## Fractal Art

A fractal artwork is one which has a pattern within a pattern, which is *nested* or *self-similar*, like the examples illustrated in Chapter 1 (Figures 2–4). These types of pattern can be constructed in a variety of ways, which generally fall into one of two categories: ‘top-down’ or ‘bottom-up’. For example, with a cellular automaton a fractal image is built up from the bottom. A pattern emerges from small picture elements (cells/pixels), which form the base level of detail in the image, as the image is generated row by row – somewhat like knitting. Alternatively, a similar image can be formed ‘top-down’ by an iterative process of subdivision. Figure 41 shows a fractal image created with these two different methods:

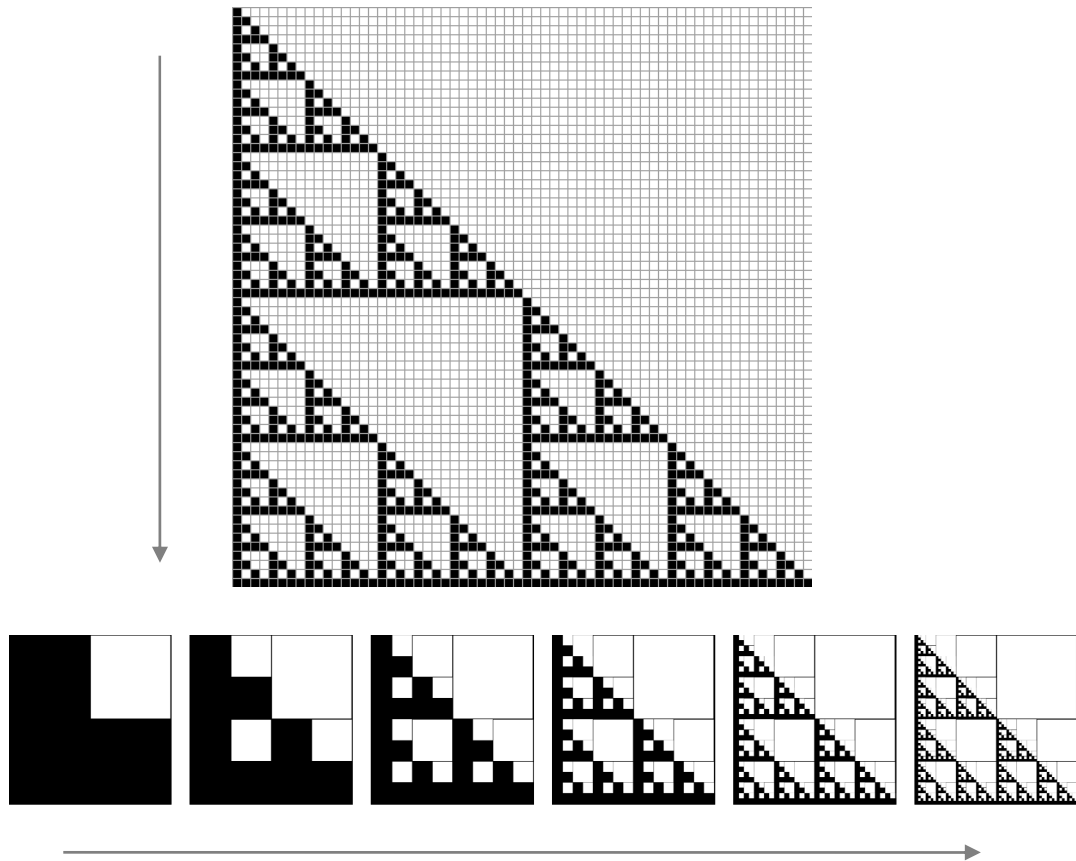

Figure 41 Fractal construction methods.

The upper image is created ‘bottom-up’ from 64 steps of elementary CA rule 60, starting from initial conditions of a single black cell. The lower series of images is made by a ‘top-down’ iterative process of copying the image, reducing in size, and pasting the copies onto three quarters of the original image. Both the large CA image and the last image in the

series below it have the same amount of detail. Each is effectively based on a 64×64 grid (the grids represented here differ for clarity), and each contains six levels of nesting.

Mandelbrot (2004a) cites Hokusai as one of the earliest visual artists to create images of fractals, in pictures such as *The Great Wave* (Figure 4). A contemporary example of natural fractals in art is the tree-like sculpture of Jorge Mayet (Figure 42) which was presumably made with a ‘top-down’ method, starting with the central trunk and adding successively smaller branches and roots.



Figure 42 Jorge Mayet, *De Mis Vivos y Mis Muertos* (2008). Electrical wire, paper, acrylics, fabric; 143 × 84 × 84cm.

Taylor, Micolich and Jonas (2002) demonstrate that Jackson Pollock's drip paintings (Figure 43) are fractal, by using a fractal measuring technique known as box-counting. Taylor's research found that the fractal dimension of the drip paintings increase over the course of their construction, as one would expect in a top-down fractal construction, which becomes more intricate as layers of paint are built up. The research also shows that during the years of their execution, the drip paintings became increasingly complex. Over the decade from 1943 to 1952, the fractal dimension of the paintings increased from around 1.1 to 1.7 (Taylor, Micolich and Jonas, 2002, p.206).



Figure 43 Jackson Pollock, *Lavender Mist: Number 1* (1950), oil on canvas, 221 x 300cm.

These findings suggest that the fractal nature of Pollock's work was no accident, and that even though the term 'fractal' had yet to be coined and the images reach a wider public awareness, the creation of these self-similar forms was a significant component of Pollock's art. It begs the question why this was not recognised before this computational analysis. It seems that the irregularity in the dripped paint masks their fractal qualities from our perception, and the high fractal dimensions of the later work in particular makes it difficult

to perceive their inherent order. A possible explanation for this is the idea of a perceptual threshold of visual complexity. The objective or informational complexity of the drip paintings is just beyond the threshold, past the peak of the inverted ‘U’ correlation with perceived complexity. Their randomness makes it difficult to perceive the inherent order, and together they contribute to the perception of visual complexity. There is something aesthetically pleasing about the irregular fractals in Pollock’s configuration of order and chaos, just as there is in the shapes generated by Scott Draves’ *Fractal Flames* (Figure 44). The generating algorithm is an iterated function system, and Draves’ contribution is to have formulated a new colouring method that reveals the fine structure of these forms (Draves and Reckase, 2007). By manipulating its parameters over time, it is possible to animate the fractals. These animations form the basis of Drave’s *Electric Sheep* screensaver project (Draves 2009), in which users can influence the selection and generation of ‘sheep’ or create their own and subject them to the same selection and generation process.

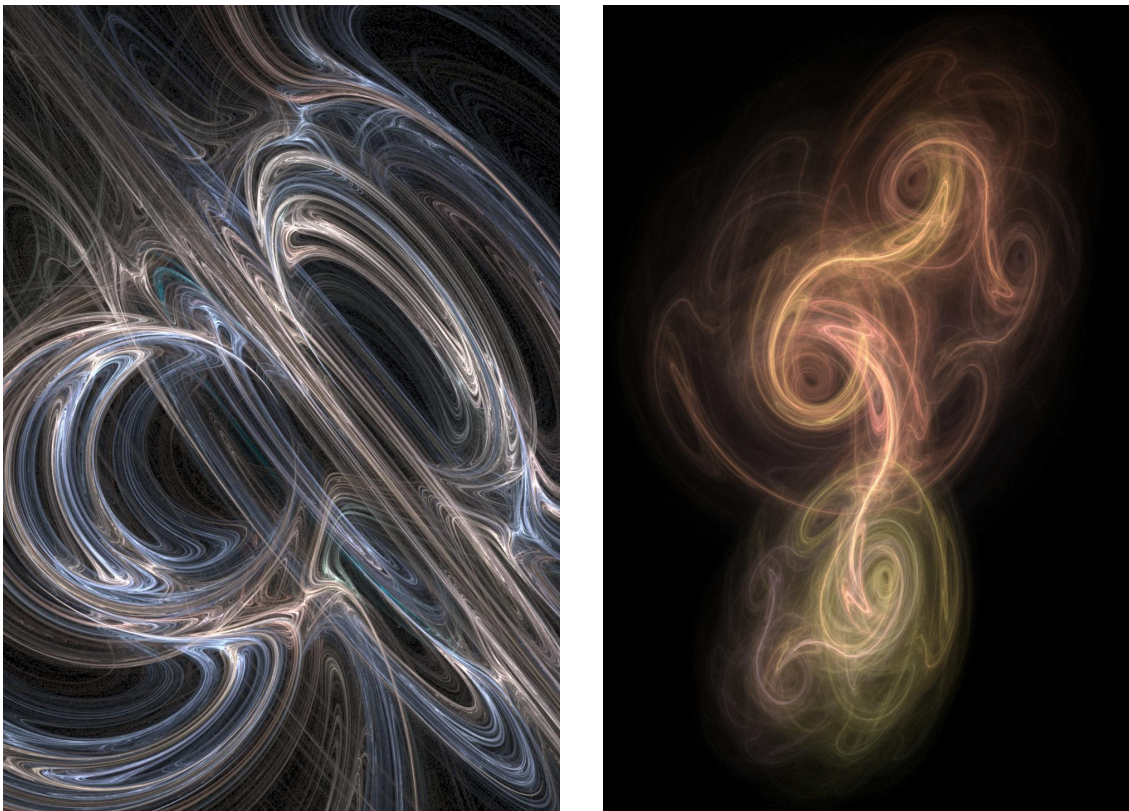

Figure 44 Scott Draves, aka Spot (2007). Two images generated by the Fractal Flames algorithm for the *Electric Sheep* project.

# Visualizing Complex Information

Unlike fine art, graphic design involves the manipulation of visual elements for a practical purpose – it is about more than just making pleasing visual forms, and so its aesthetic is always secondary to its utilitarian demands. The purpose of such graphics is to convey useful information. Edward Tufte formulates principles of design for information graphics by analysing previous instances and from his own experience in design. Tufte argues for making the most of established print and paper technology in place of poorer-resolution electronic displays. One of the most cited and celebrated graphic designs in Tufte’s book, *The Visual Display of Quantitative Information* (2001), is a map of Napoleon’s Russian campaign by Charles Joseph Minard (Figure 45). In only two dimensions on paper, this chart elegantly and efficiently represents at least six dimensions of statistical data, including the size of the army, its geographical position, elevation, and the local temperature.

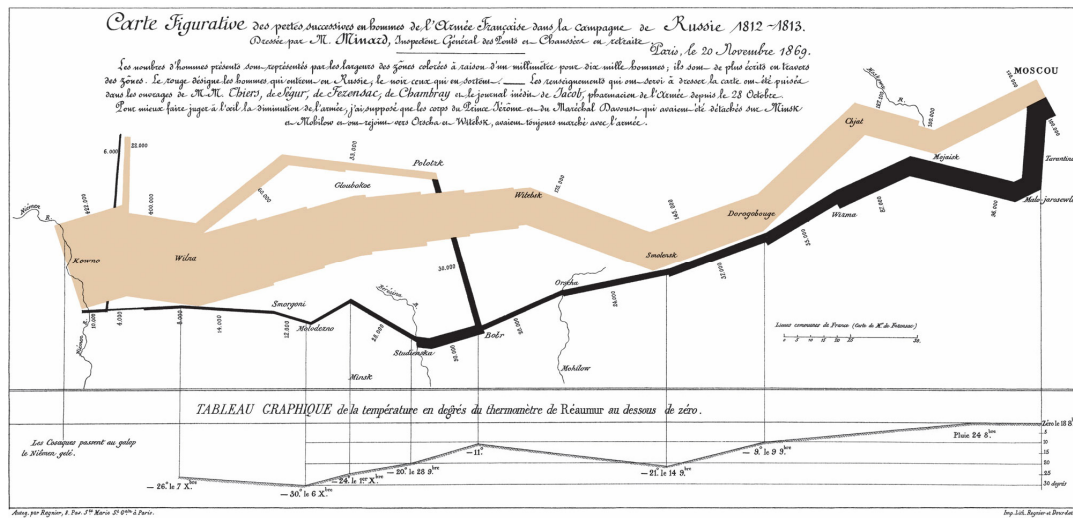

Figure 45 Charles Joseph Minard (1869). Chart depicting Napoleon’s 1812 Russian campaign. Lithograph, 62 x 30 cm.

Tufte argues convincingly that by using low-quality displays (low-resolution, poor colour reproduction, bad tone/contrast) and formulaic designs (such as the preset styles in Microsoft *PowerPoint*), we deprive ourselves of a rich visual experience that can be both illuminating and aesthetically pleasing at the same time. In fact, Tufte’s guidelines barely



make the distinction between good form and good function, so closely are they tied together in his principles. Above all, Tufte's graphics are economical – there is no visual redundancy, thus the data represented are about as 'compressed' as is possible in graphical form. Experiments by Donderi and McFadden (2004) provided empirical evidence that more information-dense images can be easier to process: When university students and professional mariners were tasked with reading naval radar and chart images, both groups showed improved efficiency in answering questions about the displays when the images were superimposed instead of presented separately. Donderi agrees that Tufte's aesthetic parallels the computational approach: "...the information-theory context of Tufte's analysis was implicit in the terms he used and the principles he advocated (2006b, p.83).

Like Tufte, Colin Ware argues for the visualisation of information, but whereas Tufte wields authority by his demonstrable graphical skill and aesthetic sensitivity, Ware utilises the body of psychological research on visual perception to strengthen his argument. Ware *et al.* (2006) produce novel methods of visualizing marine data, in this case (Figure 46), a visualisation of humpback whale movements.

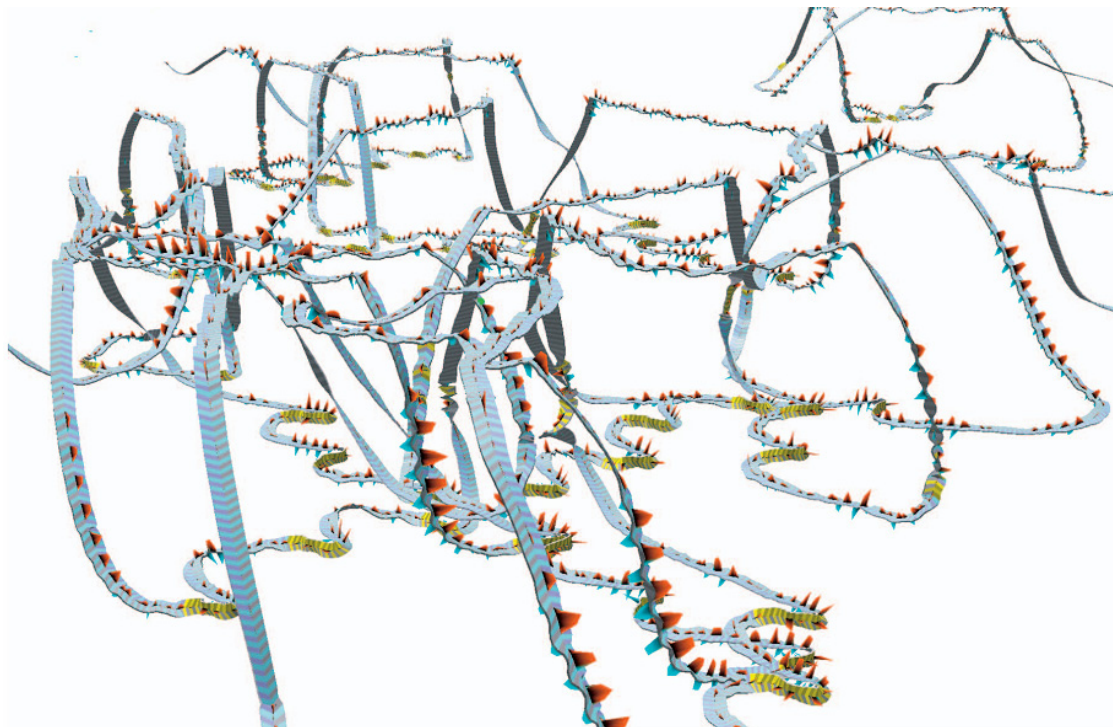

Figure 46 Visualization of whale behaviour by Ware *et al.* (2006).

In his book on information visualization, Ware (2004) not only gives a comprehensive account of the visual system and perceptual psychology, but also lists some of the psychophysical principles and methods that are used in the work he cites and in this research project. It is evident in his writing that Ware advocates a theory of active perception – the orthodox view that largely rejects Gibson’s theory of direct perception:

At higher levels of processing, perception and cognition are closely interrelated, which is the reason why the words “understanding” and “seeing” are synonymous. (Ware 2004, p. xxi)

Ware employs David Marr’s computational approach to vision to justify a set of principles for information graphic design. In particular, Ware uses Marr’s idea of the 2½D sketch to implement better graphic design. The perception of the third dimension – proximity to the observer – does not conform exactly to the line of sight; we experience this dimension in degrees, he argues. Images of occluding shapes, for example, are strictly two-dimensional, but are perceived as having some kind of depth. Joseph Alber’s painting *Homage to the Square* (Figure 38) demonstrates this effect; it appears to be composed of many squares superimposed on each other, when in fact there is only one square on the face of the canvas (the other ‘squares’ are actually shapes like an empty picture frame). The perception of depth depends on certain visual cues, and graphic techniques such as occlusion and shading can strengthen or lessen the perceptual effect.

Ben Fry explores ways of visualising large sets of complex data, and like Ware acknowledges the perceptual problems this brings. For his PhD thesis, Fry (2004) worked with one of the largest and most complex data sets – the human genome. His statement of the graphic design problem is that “The ability to collect, store, and manage data is increasing quickly, but our ability to understand it remains constant.” (2004). Fry (1997) explores methods of navigating data sets. His challenge is to come up with ways of visualizing the kind of complex and dynamic data sets that fail to be served by Tufte’s guidelines for more traditional graphic data. This kind of data changes over time, and

constitutes a new type of complexity to which the visualisations have to adapt. Another project that visualizes complex dynamic data is *Thinking Machine* (Figure 47) by Martin Wattenberg. *Thinking Machine* visualizes the moves considered by a computer chess program – ‘lines of thought’ are traced in coloured arcs that reveals the electronic opponent’s strategy, the more likely moves being traced more times. The tactical strength of each side is visualized in ripples that propagate from the pieces on the squares over which they have control.

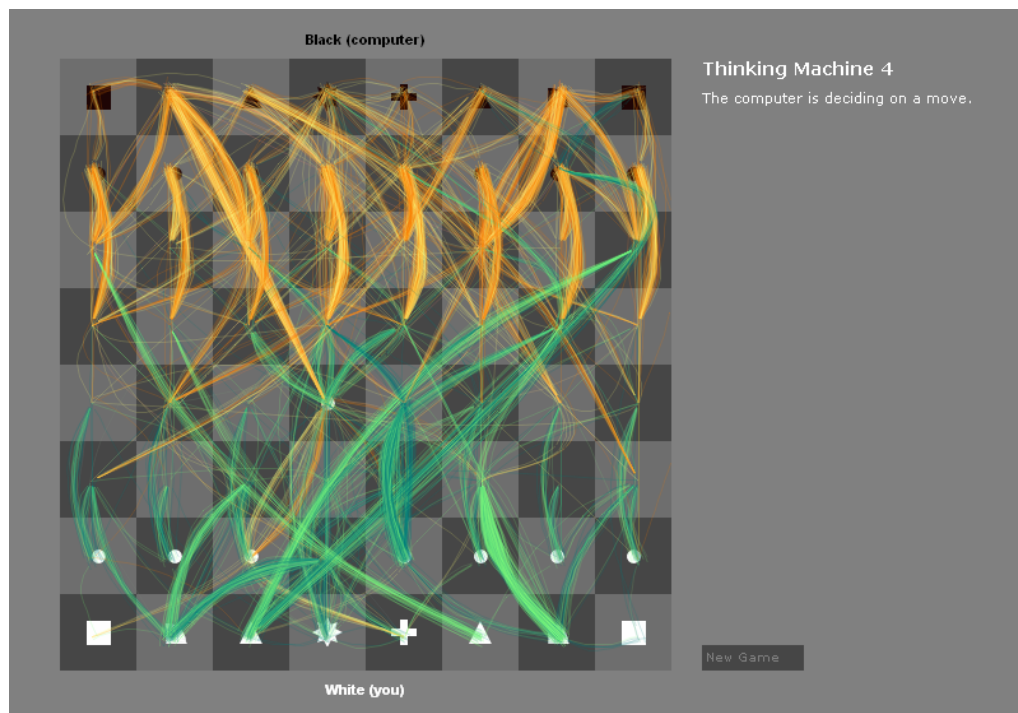

Figure 47 Martin Wattenberg, *Thinking Machine* (2002).

The website *Visual Complexity* (2009) is a resource for the visualization of complex networks, which includes the work of Fry and Wattenberg amongst topics such as art, biology, social networks and the World Wide Web. It is run by designer Manuel de Lima, whose aim is to provide a resource for the visualization of complex networks and to develop a critical understanding of visualization methods between various disciplines. After knowledge networks and social networks, art is the third most popular subject for visualizations on the site. One example is the work of Lee Byron, who wrote the *StreamGraph* software (Byron and Wattenberg, 2008). The software visualizes information

gathered through the LastFM music website which records patterns of music listening history (Figure 48). The horizontal axis represents time in weekly snapshots, and each artist is represented by a labelled, coloured stripe, the thickness of which is determined by the number of tracks played.

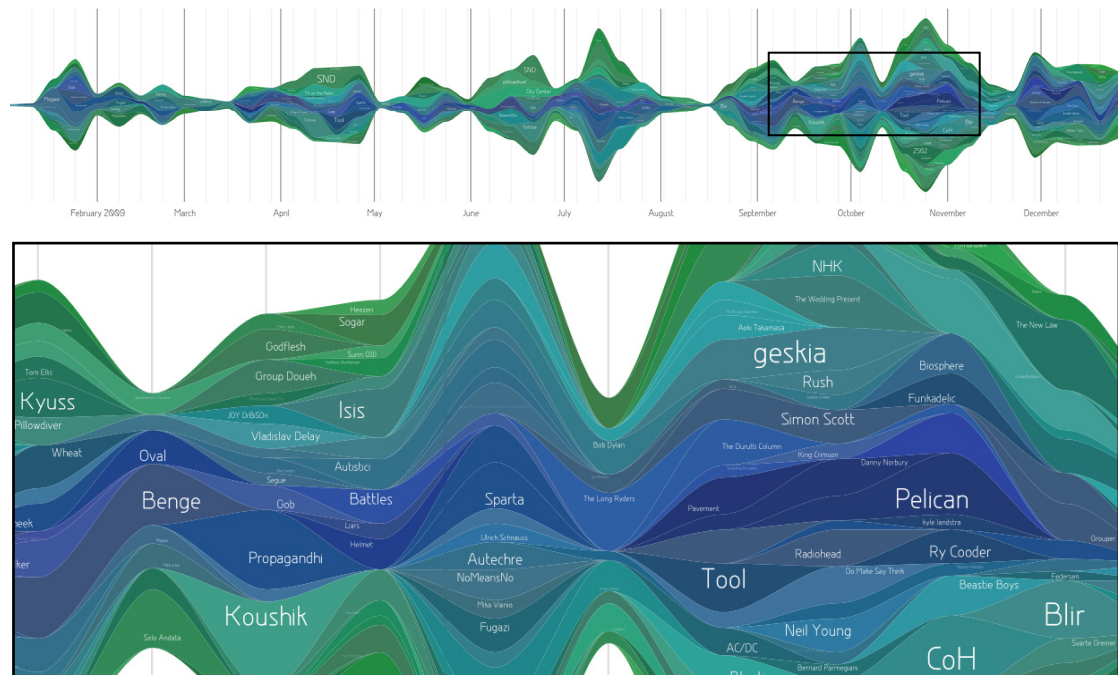

Figure 48 Visualization from LastGraph of my listening history (one year and detail).

What is interesting and valuable about the work of Tufte, Ware and Fry is their willingness to exploit our considerable powers of perception rather than pander to ill-informed principles of simplicity and ease of understanding. That is not to say that these researchers promote visual complexity for its own sake, or that they aim to produce material difficult to digest, but that in different ways they attempt to enrich our world of visual information and reveal its complexity through clarification rather than obfuscation. Ware describes information visualization as “external cognition”, a tool for augmenting the cognitive powers of the mind (2004, p.xvii). If graphic visualization is externalized cognition, then to perceive and understand information graphics is to re-internalize and incorporate visual complexity, and the task of the information graphic designer is as Tufte describes elegantly:

What is to be sought in designs for the display of information is the clear portrayal of complexity. Not the complication of the simple; rather, the task of the designer is to give visual access to the subtle and the difficult – that is, *the revelation of the complex*. (Tufte 2001, p.191, my emphasis)

These principles are followed throughout the thesis, since they seem appropriate for both the art and design context of the investigation and for the complex quantitative nature of the data that is collected and analysed. Benoit Mandelbrot wrote of the illustrations in his influential book, *The Fractal Geometry of Nature*, that they were

...designed to help make its contents accessible in various degrees to a wide range of readers, and to try and convince even the purest among mathematicians that the understanding of known concepts and the search for new concepts and conjectures are both helped by fine graphics. *However, showing pretty pictures is not the main purpose in this Essay; they are an essential tool, but only a tool.* (Mandelbrot, 1982, pp.21–22)

The same can be said of my intentions with this thesis; the illustrations are an essential tool for the description of the materials, methods and results of this study. In a review of the use of graphics in psychological journals, Best, Smith and Stubbs (2001) find that graphical presentation of data predominates in the ‘hard’ sciences: On average, 1 out of 10 pages contain graphs in journals of the hardest disciplines (e.g. physics, chemistry), and only 1 in 100 for the softer sciences (such as psychology), with the number of tables used in inverse frequency to graphs. Best *et al.* conclude that

If the softer sciences are to participate in the emergence of another golden age of graphics, its practitioners will do well to cultivate visual thinking in their research circles, take advantage of novel technologies in computing and graphic design, and even contribute actively to the evolution of graphical methods. (2001, p.164)

The cultivation of visual thinking may well increase the respectability of the softer disciplines in the scientific domain, but it seems plausible that it might also increase the accessibility of this literature to non-scientific areas. This applies particularly for the visually-literate cultures of art and design, which often comprise the objects of study for the ‘soft’ psychological research of empirical aesthetics.

## Audio-Visual Art

In this section, we look at art with potential for great complexity that combines visual material with sound and music. The first time I encountered Scott Draves' fractal animations they were projected alongside dance music. The movement of the animations seemed to follow the changes in the music, but this was a perceptual illusion because there was no physical link between the audio and the visual. The perception of disparate sounds and visuals working together aesthetically has been known as the 'Cage effect', named after John Cage<sup>8</sup>, and is called *synchresis* by the film theorist Michel Chion (1994). Chion devised the term from a combination of 'synchronised' and 'synthesis', and he documented the use of the effect in film, where the conjunction of sight and sound can be used to direct the attention of the viewer. In psychology, this effect is classified as a form of multi-modal perception, but Chion's *synchresis* is not the same thing as the more well-known psychological phenomenon *synaesthesia*. Whereas *synaesthesia* involves a confusion or translation of sensory modes (such as tasting the colour blue), *synchresis* takes the form of a multi-modal enrichment. We can use these two perceptual phenomena to consider audio-visual art by identifying to what extent an audio-visual artwork involves *synchresis* or *synaesthesia* in its construction and its perception.

In digital art, it is relatively easy to perform a *synaesthetic* transformation from one medium to another, since digital information is essentially of the same kind, whether encoded as an image file or as a piece of music. A *synaesthetic* process forms the basis of Ryoji Ikeda's music and art installation *Test Pattern* (2008). Ikeda's artwork involves "a system that converts any type of data (text, sounds, photos and movies) into barcode patterns and binary patterns of 0s and 1s" (Ikeda, 2009). The result is a dense field of inhuman sound (the extreme nature of which may potentially damage listening equipment, according to a warning sticker on the CD!) which Ikeda breaks down and weaves into

---

<sup>8</sup> My research has yet to identify a reference to this effect in Cage's own writing. Usage of the phrase 'Cage effect' appears to be restricted to the field of amateur computer graphics.

detailed rhythms. Ikeda (2009) says the aim is to examine the relationship between the “critical points of device performance and the threshold of human perception”. Jack Ox employs synaesthetic transformation of image and sound with her *Twenty-First Century Colour Organ* (2002). Ox’s system uses MIDI music files to create immersive performances of sound and 3D images. Various musical parameters are treated as data and the system creates a ‘corresponding data set’ in a visual vocabulary based on Ox’s landscape drawings and colour charts. If the system could work with live data from improvising musicians, as intended, then the piece may function as a “complex adaptive system” (Ox and Britton, 2000, p.9). Another approach to visualizing sound is that of Martin Wattenberg (Figure 49), whose *The Shape of Song* (Wattenberg, 2002) also works on MIDI music files. The system is quite simple – repeating patterns are joined by coloured arcs – but the design is pleasing and informative. The approach is comparable to the computational analysis of music complexity by Wilhelm Fucks (Figure 26) which also relies on pattern-recognition. Instead of aiming for a more interpretive translation of music in projects such as Ox’s *Colour Organ*, *The Shape of Song* sits somewhere between analytical and creative approaches to aesthetics.

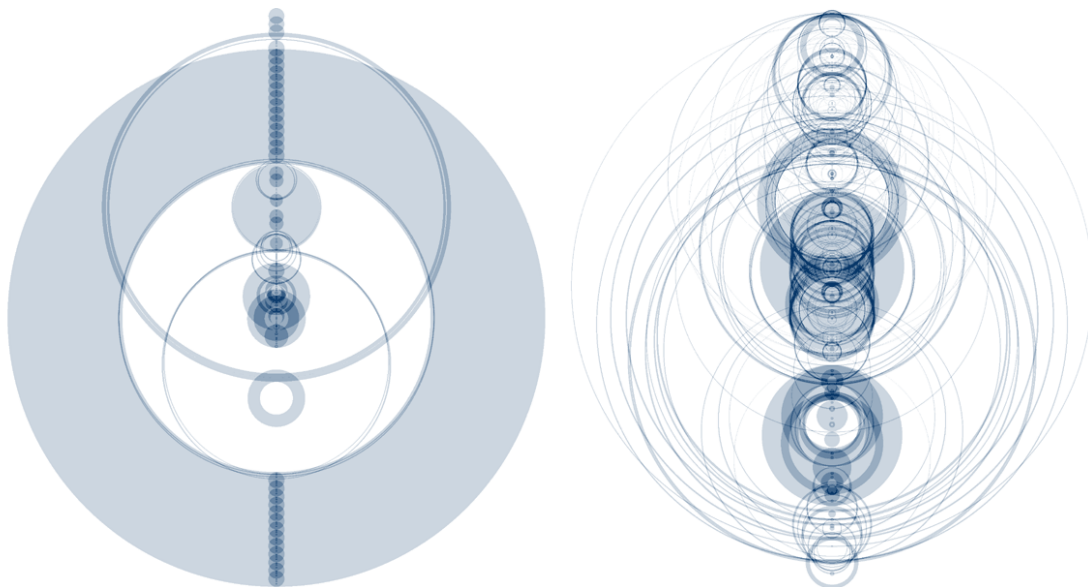

Figure 49 Martin Wattenberg, *The Shape of Song* (2001). Visualizations of *Koyaanisqatsi* by Phillip Glass (left) and *Moonlight Sonata* by Beethoven (right).

Evelina Domnitch and Dmitry Gelfand worked with scientists and musicians in the project *Camera Lucida* (2004), which exploits the phenomenon of sonoluminescence: High-volume ultrasound waves are propagated in a liquid, which induces the formation of microscopic vacuums known as cavitation bubbles. As the bubbles rapidly collapse, temperatures as high as that of the Sun are reached, and light is emitted. In this case, the liquid is 97% sulphuric acid doped with xenon gas, and the apparatus produces ghostly blue light that dances and flickers around within the tank. Domnitch and Gelfand collaborated with musicians on the record label LINE (a subsidiary of 12k), who used hydrophonic recordings to create music for the video. These musicians, including Taylor Deupree and Alva Noto (Carsten Nicolai), translated the ordinarily inaudible frequencies of the ultrasound and the bubble implosions into perceptible ranges of sound, creating synchronised musical soundtracks for the video sequences. The relationship of sound and image is one of cause and effect, so it is difficult to say whether its construction could be described as a synaesthetic transformation, but the perceived effect is certainly one of synchresis in which the two sensory modes appear unrelated but enhance each other.

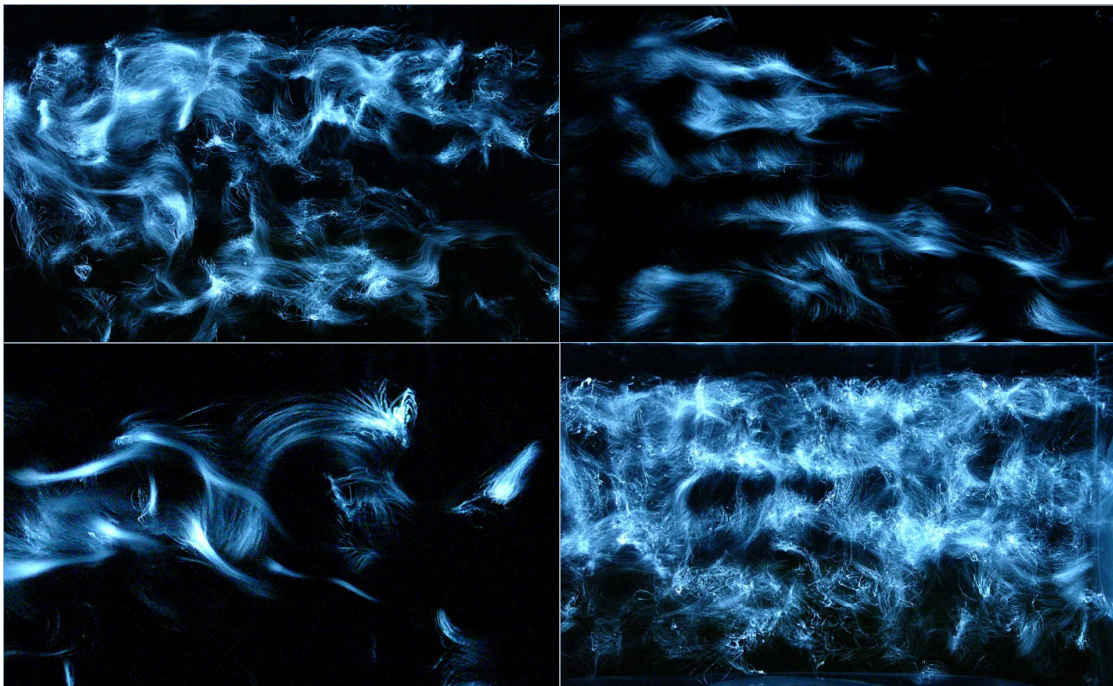

Figure 50 Domnitch and Gelfand (2004) *Camera Lucida*. Sulphuric acid and xenon gas in glass tank, with ultra-high frequency sound. Four images extracted from video.



Under the name Semiconductor, Ruth Jarman and Joe Gerhardt specialise in working with digital animation “to transcend the constraints of time, scale and natural forces” (Semiconductor, 2009). *Magnetic Movie* (2007) uses recordings of VLF radio (naturally-occurring electromagnetic signals from the earth’s ionosphere and magnetosphere) to accompany an animated visualisation of magnetic fields. Some of the movements are animated by the sounds, producing an enchanting effect of synchresis. For example, the white lines in Figure 51 grow in spasmodic bursts in proportion to the loudness of each audible event. On Semiconductor’s website, Douglas Kahn describes the film:

What we hear is underscored with complex and supple orders, in fact, too complex and supple to be ordered. We already have experience of them in the tangible turbulence of water and the crazy convection of fluids combining, tongues of fire and the thermal afterthought of smoke, the ribbons of clouds stiffly blown twisted up a hill. (Kahn, 2007)

What Kahn is describing, in so many words, are chaotic systems. Turbulence in fluids, for example, is what was originally represented in the dynamics of the Lorenz attractor – now an archetypal image of chaos. The earth’s magnetosphere is also turbulent because its molten iron core is in flux and because it is affected by fluctuating radiation emitted from the sun. The sound of this magnetic turbulence, recorded by Stephen P. McGreevy, provides a naturally chaotic soundtrack for the film. That the animation is *not* a direct synaesthetic visualisation of any particular field pattern is announced with the opening words of the film, when the scientist Janet Luhman says, “Magnetic fields, by their nature, are invisible.” Nevertheless, the way in which the sounds control the visual elements makes for a viewing experience that invites the suspension of disbelief. Without knowing the technical details of the animation, it is impossible to know exactly how much of the experience is due to the effect of synchresis and how much this audio-visual interaction is designed in its making, and this is part of what makes it fascinating.

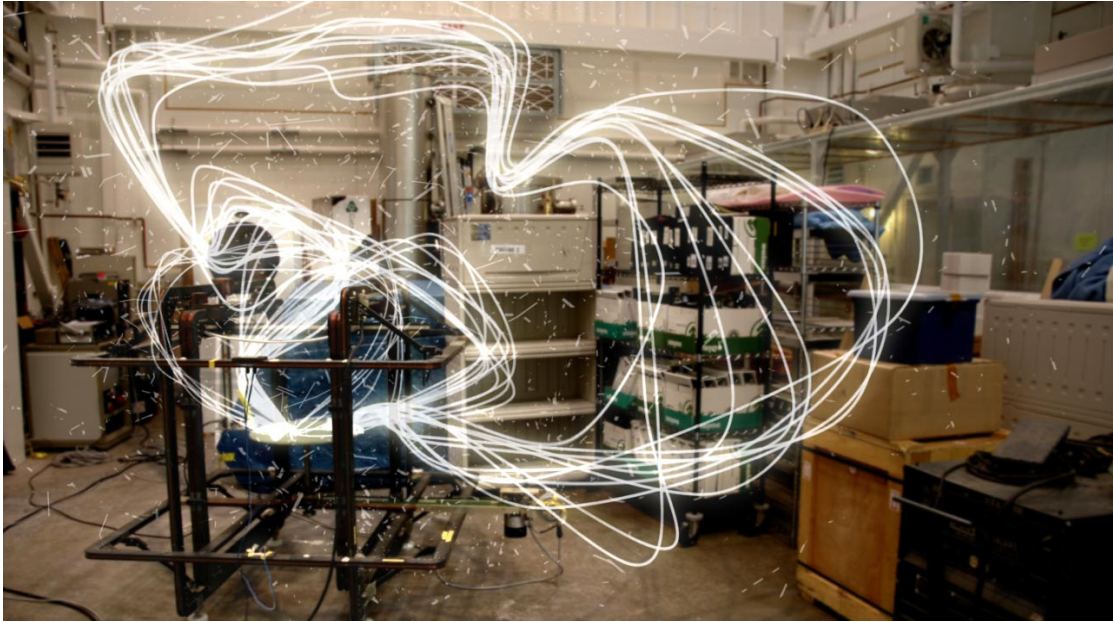

Figure 51 Semiconductor, *Magnetic Movie* (2007), digital animation.

We end this discussion of contemporary art practice with two examples of audio-visual art, whose minimal simplicity brings us full circle back to where we started. *Broadway One* by Ernest Edmonds and Mark Fell generates flat fields of hot colours with occasional blips and clicks as the image suddenly changes. Apart from their synchronicity, the relationship between image and sound is unclear. The work has a delicate balance and intriguing quietness that draws attention and questions what we are actually perceiving. Similarly, *Colour Projections* by Theo Burt is equally spare in its visuals, containing outlines of simple geometric forms that rotate slowly accompanied by slowly-changing tones (Figure 52). Like *Broadway One*, its synchronisation of image and sound suggests an underlying mechanism between the two, although the rules behind this relationship are not readily apparent. Nevertheless, I managed to learn more about the mechanism by analysing the sound, which revealed that the audio waveforms have a similar shape to the geometric graphics. At the point of the animation shown in Figure 52, we can hear a low tone corresponding to the large circle and a higher tone which appears as the smaller circle begins to cut into the larger one. The sound analysis shows that the waveform has a related shape which introduces more harmonic frequencies as the waveform is altered from a pure

sine wave. Thus the complexity of the graphics corresponds with the complexity of the waveform, resulting in a matching perceived complexity of image and sound.

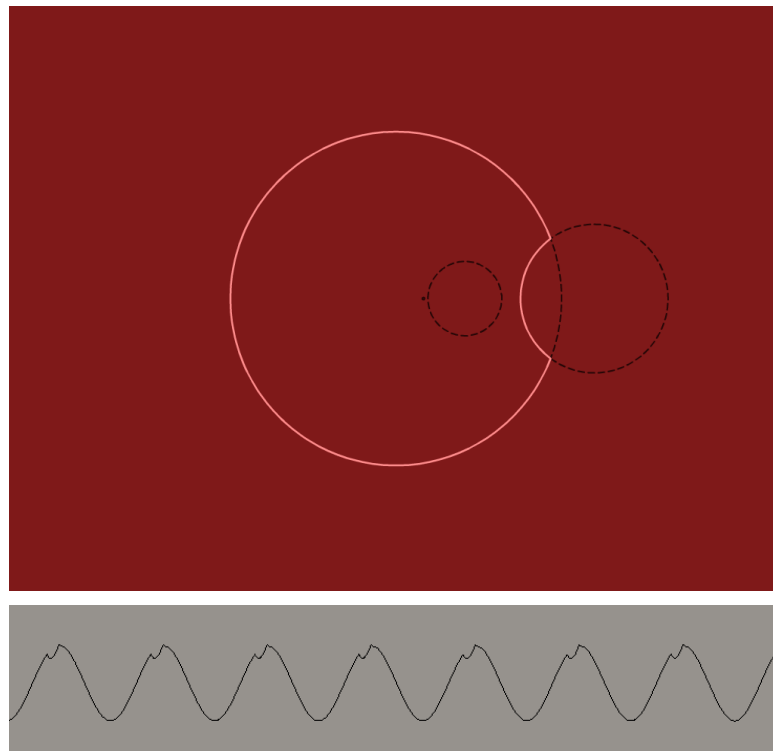

Figure 52 Top: Theo Burt, *Colour Projections* (2009), digital animation. Bottom: visualization of the audio waveform taken at the corresponding time.

Rather than translating from one medium to another, *Colour Projections* and *Broadway One* generate image and sound from internal computations as separate but related instrumental expressions. Although Edmonds and Fell describe their artwork as “synaesthetic” (2005), it could be argued that the process is more accurately characterised as synchresis, with an integration of image and sound in terms of both its production and its perception. Fell says of the work, “The emphasis is on correlations that are purely aesthetic. There is no innate or mathematical relationship between sound and colour. Anything one does is purely invented” (Whitelaw, 2007). The point is that any digital synaesthetic translation is ultimately arbitrary, with the implication that the result actually reveals more about the system and its creator than it does about the nature of the stuff that is translated from one medium to another. This notion is supported by Moles’ (1966) description of aesthetic information as being ‘untranslatable’: As opposed to semantic

information, which is based on a shared symbolic language, aesthetic information “refers to the repertoire of knowledge common to the particular transmitter and particular receptor” (Moles, 1966, p.129). The fact that any correspondence between media is ultimately arbitrary undermines the idea of synaesthesia as a process capable of meaningful translation.

What we are left with – and what really matters – is the perceptual effect of the artwork and the quality of the aesthetic experience. It seems more difficult to create the synchresis effect, but it may offer a more rewarding aesthetic experience. The most successful of the audio-visual artworks, to my mind, are the ones that achieve aesthetic synchresis, whether through an explicit connection or a more arbitrary translation process. In either case the quality of the experience appears to be dependent on the synchresis effect – the mind has to work a little to make the connection, but the effort pays off in aesthetic satisfaction. It is possible that the propensity for images to work with sounds in a synchretic experience is sensitive to their levels of complexity. In my own experience, the most rewarding aesthetic experiences of synchresis, and thus the most successful synchretic artworks, appear to have similar levels of complexity in image and sound, either at a static level or via synchronised changes. This is a potential subject for further investigation.

## **My Art Practice**

My practice has contributed to this research by generating visual material for use as test stimuli and by developing the skills and tools needed to manipulate complex imagery using computer-based programs. Figure 53 shows the last large-scale hand-made piece, which was produced for a friend and ex-colleague in return for lifts to work. The drawing is a representation of the rule number 110 elementary CA on an A1 sheet of 2mm square graph paper. The initial conditions (the top row) were produced with the rule 30 random number generator in *Mathematica* and the rest of the CA was calculated and drawn by hand, which meant that the resulting pattern was unforeseeable at the start. By forgoing the computer I discovered a way of reducing the calculation of rule 110 without having to

consider each cell in turn, which speeded up the process considerably (around three or four times faster). Nevertheless, I calculated that it took roughly the same amount of time to make the drawing as I had spent in my colleague's car on the journey to work and back over a year – around a hundred hours. The top left-hand image in Figure 53 is approximately life-size.



Figure 53 *Untitled* (2006), ink on paper (detail; in progress; finished).

Artwork produced before the start of this research was mainly based on craft techniques combined with computational processes such as cellular automata. In 2005 I attended the 5th. Creativity & Cognition conference in which I exhibited two paintings and one needlepoint piece, all based on a simple kind of block CA. I had the chance to talk

with Frieder Nake, initially about a line from Thomas Pynchon's novel *Vineland*, which I was reading at the time:

If patterns of ones and zeroes were "like" patterns of human lives and deaths, if everything about an individual could be represented in a computer record by a long string of ones and zeroes, then what kind of creature could be represented by a long string of lives and deaths? (Pynchon, 1998, p.90)

In conversation, Frieder said that he had learnt to not get annoyed when artists try to use computers to do things like recreating natural scenes and images, which is so difficult to achieve digitally that the results are often poor representations of what we usually perceive. Computer graphics of natural forms and textures, for example, may seem incongruous when juxtaposed with photographic images and they often date rather quickly. Frieder saw more aesthetic value in work that makes use of the computer's digital nature, rather than work that fights against its visual characteristics. 'Use the computer for what it gives and what it is good for; work with it, not against it' was his message. This is exactly the point of Frieder's own work, and with these comments his aesthetic of simple visual elements is seen in a new light that makes it seem less ascetic and more open. In one sense, it is an approach similar to that of the minimalists – a truth to materials. Using the computer to recreate natural scenes is thus more artificial than making use of its own visual language. Frieder's conversation had a profound effect on my own practice, giving a new direction to the production of computational artefacts. It did not negate my view that in general the hand-made offered a more complex and appealing aesthetic than the digital, but it showed a way in which the inherent (and sometimes off-putting) visual character of digital art could be turned on itself to produce a more honest kind of artwork. Now, the digital could be used without regret or apology for its visual nature.

A defining feature of digital art is that it is based on fundamental discrete units – numerical digits that are represented internally as binary magnetic or electrical charges and externally as dots in print or pixels on screen. If an artist is trying to recreate a natural visual scene, then these pixels should be imperceptible and their tell-tale characteristics are

avoided (such as aliasing – the appearance of discontinuities in what should be smooth lines or gradients). But if one accepts this characteristic, as Frieder Nake suggested, then the idiomorphism of digits and pixels becomes a creative tool and a visual palette. The result on my practice was to explore these features, principally by working with raster (pixel-based) images, manipulating and building images a pixel at a time. Figure 54, for example, is an unashamedly digital image which explores the perception of three-dimensional form as represented in two dimensions and the impossible figures that can be created between these modes of representation.

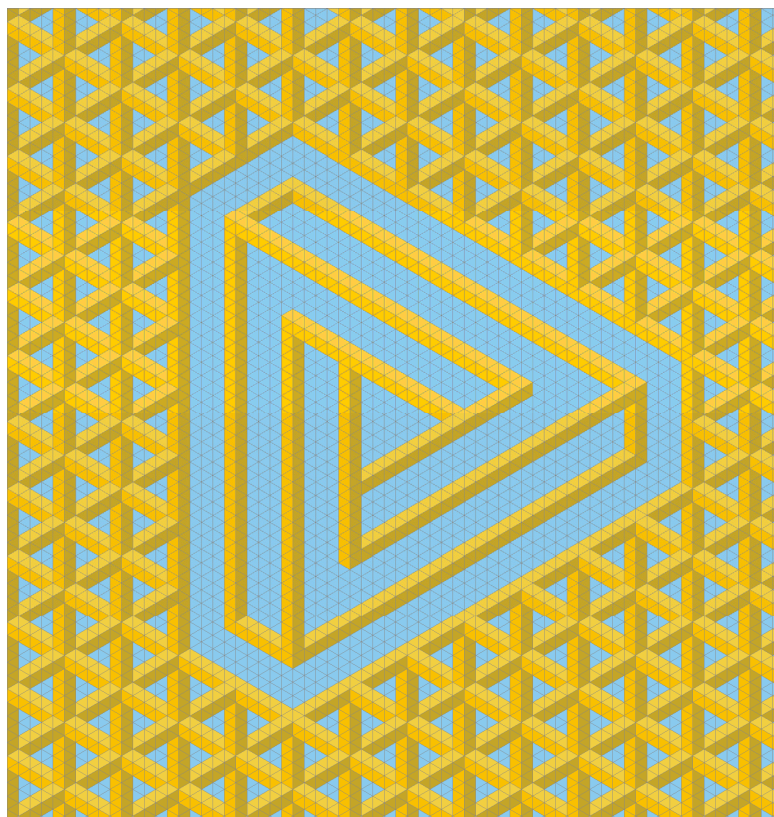

Figure 54 *Iso C* (2006), digital image.

To exploit the properties of digital media as Frieder Nake had described, I began to use the kind of software that has the opposite aim of recreating natural effects and realistic images. Ray-tracing is one of the techniques of computer graphics used in this regard, based on the modelling of light and its interaction with surfaces and translucent media. The path of a light particle is modelled from source to surface to eye, enabling the recreation of

realistic three-dimensional illumination in two dimensions. This modelling is fairly complicated for a single ray of light, but to generate an entire image requires many such rays to be traced, which requires a lot of processing power and time. The default settings for many ray-tracing programs is to model the physical behaviour of light, but these rules can be manipulated and the resulting images modified to create novel visual effects that would be impossible in the real world. For instance, the amount of light reflected and absorbed by a surface normally adds up to the amount transmitted to it, but by tweaking the rules we can produce effects whereby the amount of light reflected exceeds these limits (Figure 55). For me, this was using the computer as *Nake* described, freeing it from the attachment to our normal perceptual world and opening it up to aesthetic exploration. The same can be said for Semiconductor's use of digital animation to escape the limitations of the visible physical world. In essence, the process is analogous to the inventive use of photographic technology in Man Ray's 'rayographs' and Marco Breuer's 'photographs' made without a camera.

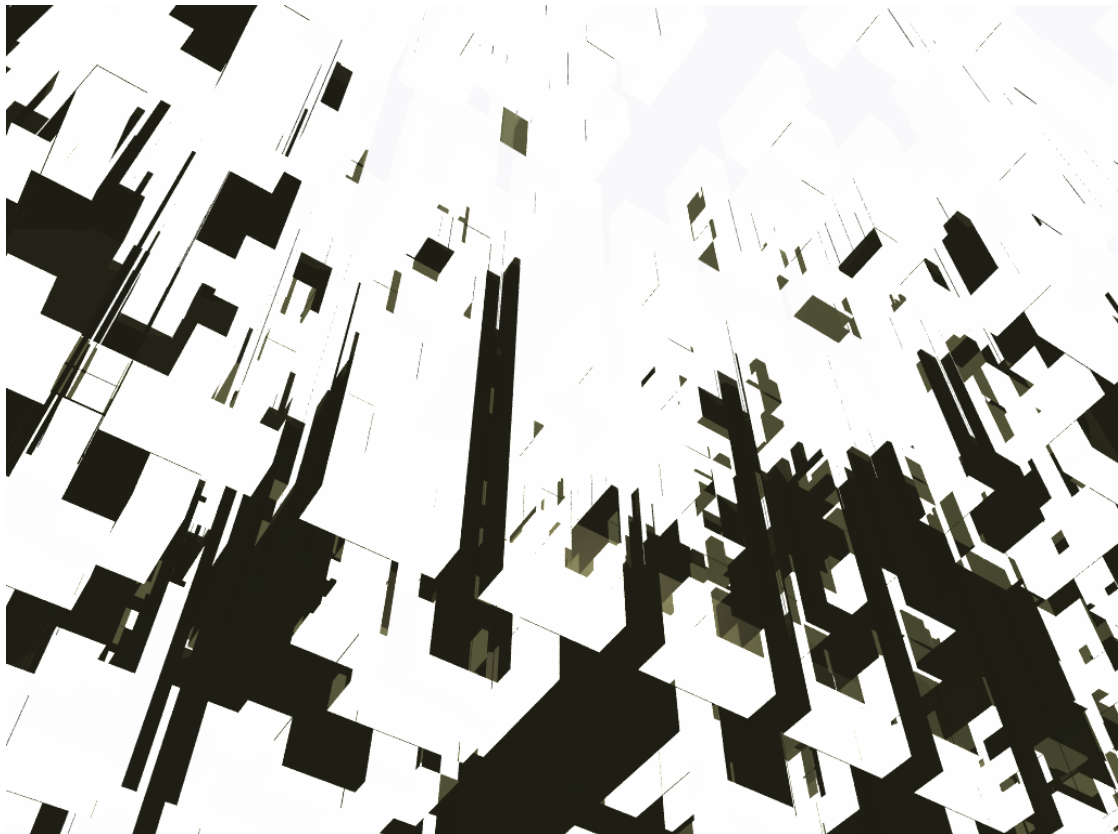

Figure 55 *P32b inv greens* (2007), digital image.



In my previous job as a biology technician, one of my responsibilities was preparing visual material for teaching. This included tasks such as preparing projections from a video-equipped microscope as well as creating slide presentations for teachers or printed handouts for students. Amongst the visual resources I used was a collection of high-resolution scanned images from Ernst Haeckel's *Kunstformen der Natur*, which was originally published between 1899 and 1904 in volumes of ten prints. Haeckel's illustrations show the marvellous diversity and commonality of forms in the natural world, grouping images of parts or whole organisms in symmetrical arrangements on the page to illustrate a particular morphological theme. I obtained permission to use the images from Prof. Kurt Stüber, who had scanned an original copy of Haeckel's prints and hosted them on his website (Stüber, 1999). I used these digital images in combination with cellular automata patterns produced in *Mathematica*, firstly by overlaying the CA patterns on the Haeckel images, and later by using the CA pattern to invert areas of the image beneath. Figure 56 shows a detail of this process, in which the individual pixels are visible. Elementary CA rule 110 has been used as the overlaying pattern, and its triangular shapes are the areas in which the Haeckel image has been inverted (white becomes black, red becomes green, etc.). Figure 57 shows an entire image made using this process, a copy of which is used in Test 3. These digital prints were produced such that the individual pixels remained visible. Ordinarily, this would have made the original images quite unpleasant as compression artefacts could be revealed, but the added complexity of the CA pattern obscured this. To my mind, this process produced some of the most complex images, which were just on the right side of the edge of chaos and the threshold of perceivable visual complexity. The overall effect of this technique is to reduce the contrast and colour saturation at a distance, whilst a closer inspection reveals diverse tones and adjacent complementary colours. Because the colour-inverted areas occupy just less than half the total area of the eCA rule 110 images, the resulting inverted image still retains some of its original hues and tones when seen at a distance (conversely, inverting the other area of the pattern produces the appearance of a negative).

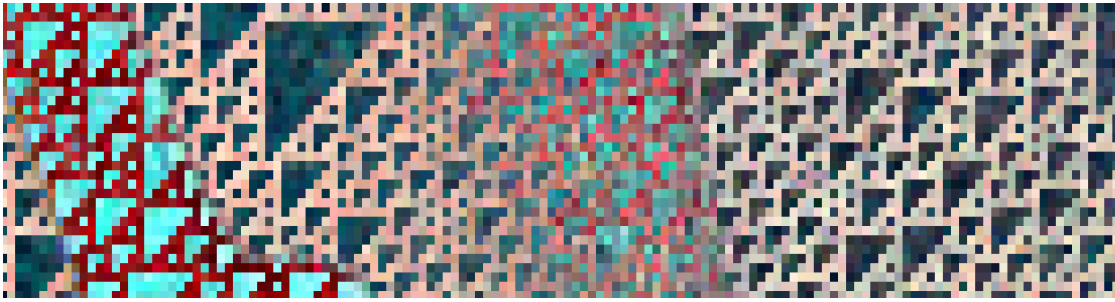

Figure 56 *Tafel\_008\_300 + 110 D3* (2007), digital image (detail).

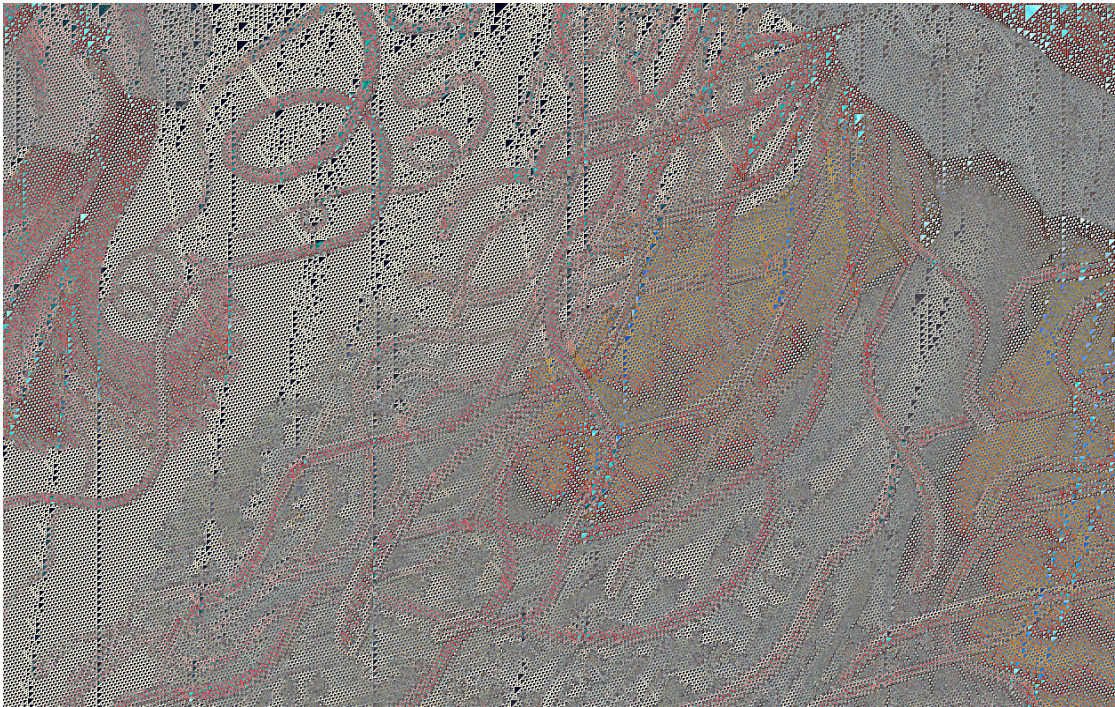

Figure 57 *Tafel\_008\_300 + 110 D3* (2007), digital image.

In 2007, I entered a competition for a commission for the Minster School in Southwell, Nottinghamshire. The brief was to design and produce translucent sliding doors and a skylight for the new school building. The doors were to separate the main hall from a small chapel, and the skylight was for the chapel's ceiling. My entry was based on a block cellular automata pattern in a spectrum of colours. The underlying pattern is based on a rectangular repeating black and white pattern, but the colouring scheme I developed made it difficult to perceive its underlying simplicity. The image used in the final design (Figure 58) repeats horizontally, such that the left edge would match up with the right if put together (if the doors ran past each other and swapped places). I was quite pleased with the design, but unfortunately it was not chosen for production.

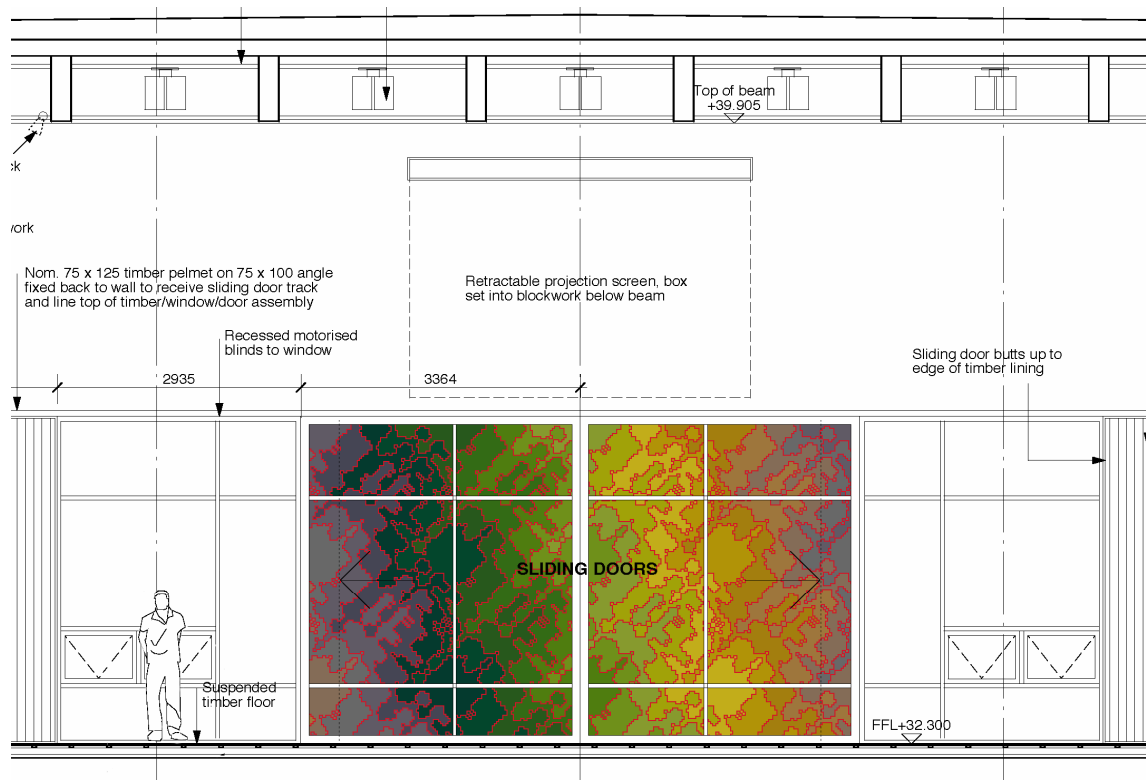
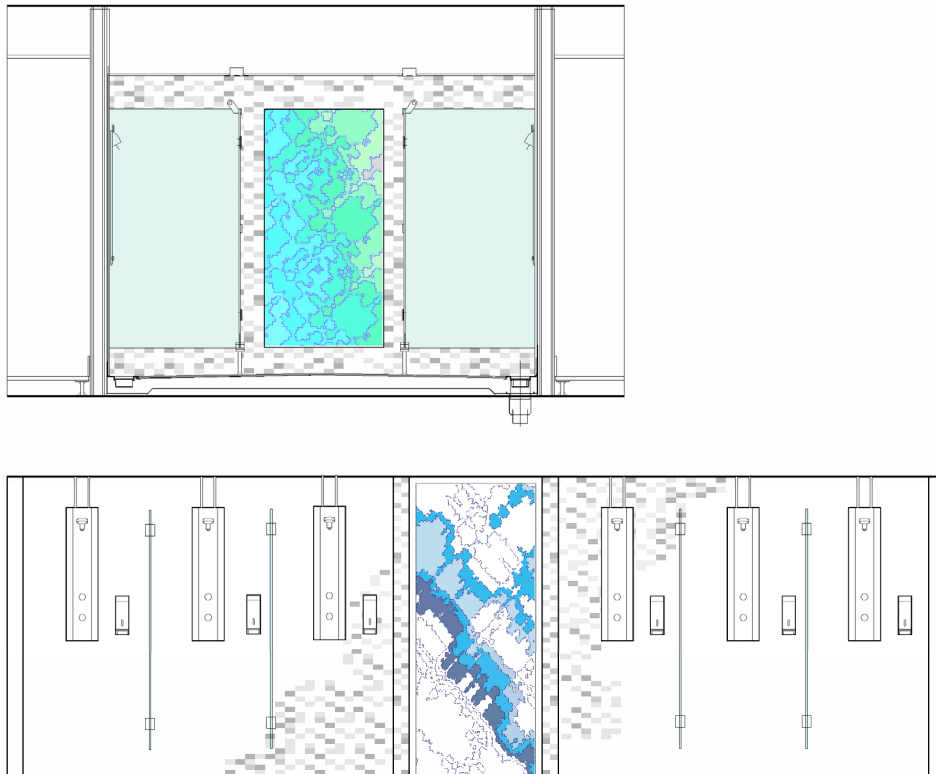

Figure 58 Architectural design of translucent sliding doors for Southwell Minster School commission (2007), digital image.

Shortly after the Southwell competition, I accepted a commission to create wall designs for the refurbishment of the Deutsche Bank headquarters in London. A friend and former colleague had contacted me as he was leading the team of architects that were doing the work. The job had to be done with very short notice, and so I used some of the patterns I had been working on for the Southwell commission. In this brief, the colours were specified by the client. I produced about twenty design variations within a couple of days, and the client selected two of these for production (Figure 59). The designs were for decorative tiled walls within four employee shower blocks. A total of twelve prints were produced on adhesive vinyl, which were adhesive on the printed side and mounted onto glass panels fixed to the walls to protect them from moisture and abrasion (Figure 60). I think the low complexity of the images work well with the relatively plain surroundings, and the pattern echoes the shape of water dripping down glass and puddles on the floor.



ELEVATION A-A

Figure 59 Architectural designs for the Deutsche Bank shower blocks.



Figure 60 Photograph of installed wall decorations, Deutsche Bank, London.

# Summary of Context

Discussions of aesthetic problems can be traced back to Plato and Aristotle, when the ancient Greek word *aestheta* referred to things perceptible by the senses. When Baumgarten coined the word 'aesthetics' in the eighteenth century, it meant a science of sensory perception; however, the term gained more currency in the art world, as ideas of beauty were replaced by theories of taste. The scientific study of aesthetic perception did not begin until a hundred years after Baumgarten defined the term, mainly due to the difficulty of measuring perceptions. This field is known as psychophysics, so named because its aim is to establish relationships between processes of perception and events in the physical world.

What were previously regarded as scientifically unsurpassable divisions between the mental and the material are now providing fertile grounds for research. Empirical studies of the arts fall into this category, and are currently experiencing a burst of growth. However, objections that the complex nature of creative cognition cannot or should not be examined empirically are still heard in both the artistic and scientific communities: Art and its experience is complex, but scientific study is selective and its results are limited. In consequence, much of the scientific study of art has concentrated on solving simple, manageable problems, or has been content to make only modest claims.

Perhaps surprisingly, even studies of visual *complexity* have mostly concentrated on relatively simple geometric images, and studies that use actual works of art in empirical research are scarce. It is almost as if real artwork is *too complex* to be examined empirically. The lack of engagement with the complexity of visual art provides the context for the current enquiry. The empirical part of this research project aims to counter this trend by conducting tests of visual complexity using real artwork, and to answer the question: How complex *is* contemporary visual art, in terms of objective properties and aesthetic perception, and how does it relate to aesthetic value?

Emergent themes include the various ways of approaching visual complexity in terms of understanding, visualizing, or analyzing. Even within the relatively small field of empirical aesthetics, the topic of visual complexity has been approached from a number of disciplines, including art practice, art theory, perceptual and cognitive psychology, complex systems theory, and computer graphics. These studies generally rely on conceptual frameworks from either information theory and/or psychology, depending on the extent to which the focus is on objective or subjective complexity. Although there is evidence of the influence of scientific research in the arts, there is very little flow in the opposite direction, which is perhaps explained by the move away from perception of contemporary art theory and its rejection of empirical aesthetics (e.g. Dickie, 1961). In one sense, psychology is central to any scientific enterprise because everything we know is based in the mind. Similarly, the philosophy of the mind stands at the centre of all philosophy. In addition, since everything we know comes to us via the senses, we ultimately arrive at perceptual psychology in asking questions about aesthetics. The difference between psychology and the philosophy of mind is that the former deals with specific scientific questions, and the latter with a more general kind of question which cannot be answered empirically.

Empirical studies of aesthetics can be divided into two categories: What might be called the analytic (or elementary) approach employs real artworks as stimuli, whereas synthetic (or holistic) approaches use abstractions of artworks such as simple geometric diagrams. Each comes with a drawback: The synthetic approach aims to circumvent the practical difficulties in experimentally measuring or controlling the properties of real artworks as stimuli, but this move simultaneously weakens the validity of generalizations that can be made about actual artworks and perceptions of their properties.

The problem with objective measures of artworks is twofold, and is not a fault of the measures themselves: The difficulty lies in the fact that artworks are likely to be more visually complex than the geometric figures of psychological tests, and that it requires a complex system (whether a method, mechanism or organism) to recognise this visual

complexity. In theory, then, the accuracy of an aesthetic measure can be improved by more closely imitating the functioning of our visual system (by taking into account the same visual properties that we perceive), but the greater intricacy of the measure makes it more difficult to apply in practice. Another problem is that the range of visual complexity in many experiments has been limited to rather narrow bands, such that it is difficult to envision the response across the entire spectrum.

Berlyne (1971) identified visual complexity as one of the ‘collative variables’, together with novelty, ambiguity, uncertainty and surprise. These are the aesthetic properties that involve comparison. As such, they cannot be measured as directly as the ‘psychophysical variables’ like brightness or loudness that correspond to simple physical phenomena, because comparisons require something capable of comparing, whether it is an analytic method or a sentient being, and which therefore influences the results of the measurement because it must select which features (of those that are perceptible to it) to include in the comparison. As aesthetic properties, therefore, the collative variables are a function of perception and/or cognition, and not solely properties of a thing itself. Due to this context-dependency, there can be no ‘truly objective’ aesthetic measure in the sense of it being more ‘true’ than any other<sup>9</sup>. However, that is not to say that a particular metric cannot be ‘objective’ insofar it can be replicated and verified, nor that one measure may be more appropriate or more useful than another.

Measuring only subjective perceptions of aesthetic properties can tell us much about individual perceptions and individual works of art, but it is difficult to compare and infer from these studies due to the variability and specificity of their results. An objective measure, on the other hand, can be used to construct a scale to which subjective data can be compared. If we can determine the (mathematical) relationship between the two scales, we can use the objective method to predict perceptions of other measured artworks.

---

<sup>9</sup> A similar context-dependency also appears in many definitions of complexity, a feature that sets complexity theory apart from other areas of scientific study.

The experiments of Berlyne (1971) and Martindale, Moore and Borkum (1990) fall into the category of the synthetic approach when they used geometric stimuli such as random polygons. These methods are not applicable to artworks because objective visual complexity is measured as a function of the number of turns in a polygon, and it causes potential difficulties. Martindale *et al.* showed this to correlate poorly with subjective ratings of complexity, even for these polygons. We could employ a more elaborate definition of objective complexity, which would take account of such variables as the number, regularity, homogeneity, density, and redundancy of picture elements, but this would make for an even more unwieldy tool or measurement, even if it could be automated. Aesthetic measures devised by George Birkhoff (1932) and Hans Eysenck (1941b) took just such an approach to arrive at conflicting theories. Birkhoff's (1932) aesthetic measure was a product of order and complexity:  $M = O \times C$ , whereas Eysenck (1971) proposed a function of order divided by complexity:  $M = O / C$ . Both these measures have been shown to be too simplistic, and their methods of enumerating properties, although reasonable, are too complicated to use on real artworks (not least because of the ambiguity of even the formal – let alone semantic – content of a picture).

An information-based measure of visual complexity, such as that of Donderi and McFadden (2004), provides a more plausible approximation to perceived complexity, but with knowledge from complex systems (Gell-Mann, Wolfram, Langton) we now understand why this too has its limitations. Measures such as AIC deviate from our intuitive notion of complexity, but they are useful in illuminating the relationship between objective and subjective aspects of complexity. Further, whereas some measures are too elaborate to cope with the variety and complexity of all but simple geometric figures, image file compression provides a practicable method of measuring the visual complexity of a wide range of visual material including images of contemporary artworks. It constitutes perhaps the most practicable objective measure of visual complexity because it requires no special computing capabilities or software beyond those of an ordinary PC, and takes



almost no time to determine, unlike the fractal measures which involve a more detailed computational analysis. Another reason for using this method is that it is more widely applicable than fractal measures, such as that of Taylor, Micolich and Jonas (2002), which are restricted to fractal images. Donderi's file-compression measure provides an efficient and reproducible measure of image complexity.

Using file size as an indicator of complexity makes it equivalent to Kolmogorov complexity or algorithmic information complexity (AIC), in that both can be considered a measure of information. This suggests that a measure of visual complexity based on such a scale means that it may diverge from perceived complexity for random images. This hypothesis predicts an inverted 'U' shape correlation between objective (file-size) and subjective (MES) measures of complexity. Here is one area in which we may contribute to knowledge: by providing empirical data to test this hypothesis.

## **Identifying the Components of Visual Complexity**

We have identified a number of different schemes for classifying and understanding visual complexity, based on a variety of aesthetic properties. The informational scale of complexity has order and randomness at opposite ends of its scale, but understanding of visual complexity may be based on other conceptual pairs, as Berlyne observed:

The idea that aesthetic value requires a combination of two partly opposite and partly complementary factors has cropped up repeatedly over the centuries. They have been labelled "uniformity" and "variety" by Hutcheson (1725) and many later writers, "order" and "complexity" by Birkhoff (1933), "subjective redundancy" and "statistical information" by information-theoretic aestheticians (Gunzenhauser, 1962), "concinnity" and "empathy" by Coates (1972), [and] "coherence" and "mystery" by Kaplan (1973). (Berlyne, 1971, p.9)

It should be noted that these complementary pairs are not always conceived as diametrically-opposed properties (like hot and cold), but can also be understood as being at right angles to each other. In other words, we should imagine that together they form two orthogonal axes instead of a single linear scale. (We will leave to one side the question of

whether these conceptual pairs actually correspond to hedonic functions of the nervous system, as Berlyne suggested, since it is beyond the scope of this investigation.) In this project, we have two such orthogonal factors: complexity and order. Perceived complexity is the principal object of investigation, understood as a scale of simple–complex, which constitutes the first factor. On the other hand, the objective measure of complexity by compressed file size gives a scale of order–randomness, and this constitutes the second factor. The project’s contribution to knowledge is based on the measurement and correlation of these two aesthetic factors: The complexity factor is based on the reported perceptions of test participants viewing a series of images. The order factor is based on the formal properties of the images’ digital files, quantified through data compression. The project aims to contribute to knowledge by extending the range of these factors under investigation: Firstly, by sampling the entire scale of order–randomness using computer-generated images to gain a wider picture of the subjective response to this range; Secondly, by testing samples from contemporary art and design practice to see whether we can relate these measurements back to the overall view developed in the first tests.

Here we present a model of the most pertinent variables that contribute to visual complexity, developed from the material reviewed earlier in this chapter. Using the general notion of complexity as difficulty-of-description, the images in Figure 61 represent a scale of increasing complexity. If we describe each image completely and succinctly, the size of the descriptions increases from left to right:

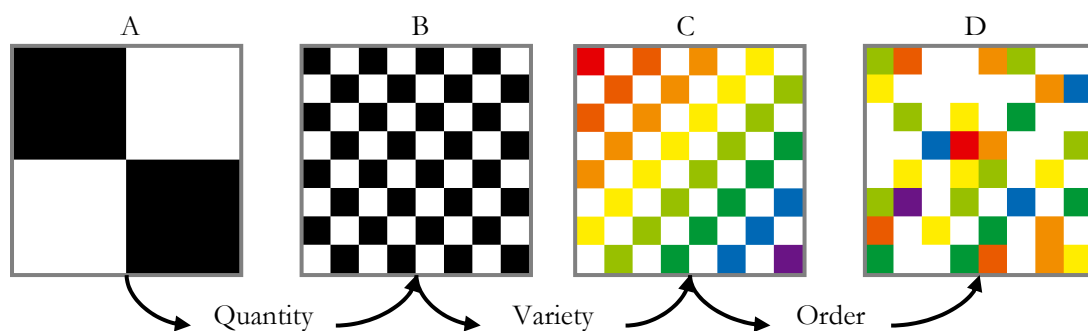

Figure 61 Three principal components of visual complexity.

The differences between pairs of adjacent images illustrate the main components of visual complexity. The difference between images A and B is one of *quantity* of picture elements; the greater quantity in image B makes it more complex than A. Image C increases the *variety* of elements by increasing the number of colours from two to nine, and so C is more complex than B. Image D contains the same elements as C, but their *order* of arrangement is different – C is more regular and so D is more complex. In summary, the main properties that contribute to visual complexity are the *quantity*, *variety* and *order* of picture elements. The three components of visual complexity identified here are more than theoretical; they share a correspondence with the most significant perceptual elements and also with the principle components of digital image files. For the purpose of the project's empirical tests, we need to constrain the quantity and variety of picture elements, while manipulating their order. Each test must use a set of images with identical pixel dimensions and the same colour system. In summary, then, visual complexity can be measured in many different ways, based on various elemental properties. These elements of visual complexity can be represented by digital images, thus they can be reduced to the common elements of digital image files, namely: the dimensions of the pixel array (quantity), the colour values of the pixels (variety) and the locations of those colour values in the array (order).

## **Visual Complexity and Image File Compression**

One problem with trying to compare empirical studies of visual complexity is the lack of a standard metric. Forsythe *et al.* (2003) argue that an objective measure of visual primitives (in their case, edges) may provide a valid index of complexity for all 2-D stimuli. Their perimeter measure of edges is based on Attneave's (1954) informational approach, but with the benefit of using computer technology to implement the aesthetic measures and analyse the results. Donderi's file-size measure is also reliable and convenient, and also has the potential to become a standard metric which may be favourable to edge-detecting measures for its simplicity and its direct correspondence with the informational content of a digital image. Donderi's measure is applicable only to images of the same dimensions,

however, because the size of a compressed file is less dependent on the randomness of its data than on its dimensions. On its own, a file-size value tells us nothing about the complexity or dimensions of an image; it only becomes meaningful in comparison with other files of the same type. There is a need, then, for a more informative metric. One potential measure is the *compression ratio*, which expresses how much a file's size changes after compression. There are reasons to believe that 1) not only would this give a relative measure of randomness but also that 2) it might allow for a comparison across different image dimensions. These two points are explained in more detail below:

1) Using the compression ratio gives a clearer idea of randomness than does the file-size alone. A totally random image, which cannot be compressed at all, will give the same file size as any uncompressed image with equal dimensions. Therefore, the relative size of a compressed file tells us how close it is to being purely random, and so the compression ratio (compressed size divided by uncompressed) gives a quantitative measure of how random an image file is. A compression ratio value near to 1 indicates incompressibility, and therefore randomness, whilst a value near to 0 indicates high redundancy and order. This relative measure is more useful than the absolute measure of file size because the latter measure only becomes meaningful in comparison with other measured values.

2) It seems intuitively correct to assume that a given pattern will have a compression ratio that remains roughly constant across a range of image dimensions, such that a small check pattern will have a similar compression ratio to a larger version. To find out, we could use a large image from which reduced-size copies are made, and calculate the compression ratio for each size. If the ratios stay the same for a pattern or type of image, then we can be confident that this measure is unaffected by image dimensions, unlike the absolute file-size. We may expect that ratios will be fairly consistent for most image types, but also that they will drift as the images become smaller and the distinction between randomness and complexity becomes increasingly uncertain. It may be possible to test this

technique more thoroughly in future, but in the current project we evaluate its effectiveness compared to the method established by Donderi based on the absolute file size.

## Locating Visual Complexity

With an understanding of informational measures of visual complexity and the results of empirical tests of its perception, we may be able to determine more precisely where the most complex and interesting images are to be found on the informational scale of order–randomness. Since Donderi & McFadden (2005) and Besner (2007) used file-size and not compression ratio, we cannot make any quantifiable statements about how perception varies with the randomness of those image files, because we cannot determine quantitatively how random those images were. We may, however, learn something from Dodgson’s findings:

...humans can easily detect patterns when up to about 25% of the pattern is removed or disturbed, that removal of over about 50% of the pattern destroys it, that there is an aesthetically interesting region between these two values, and that a good, artistic, balance between regularity and randomness is achieved by retaining about two-thirds of the pattern, while manipulating the other one-third in some way. (2008, p.112)

Dodgson’s results shed light on the question of where perceived complexity is to be found on an informational scale of order–randomness. If we fail to perceive patterns beyond about 50% randomness then this is a threshold of visual complexity, since it is effectively the ‘edge of chaos’ in perceptual terms – the point just before randomness. The images that we perceive as most complex will be found near this threshold, and a region of visual appeal is circumscribed by this threshold and a lower bound of 25% randomness, centred roughly at one third. Because the file-compression measure of visual complexity is technically a measure of randomness, we can translate Dodgson’s estimates to a scale based on the compression ratio of image files: We can expect the most appealing images to be found in files with one third randomness, that is, with a compression ratio of approximately one third (Figure 62).

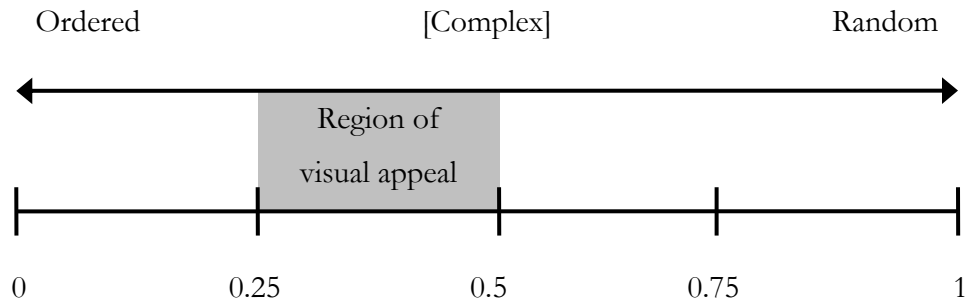

Figure 62 A scale of order–randomness (top) corresponding with compression ratio (bottom).

We should, however, be careful about extrapolating from Dodgson’s experiment because it was limited to images composed of only a few simple elements – black disks of various sizes on a white background, and also because it is not a formal empirical investigation. We may well find that these estimates of the region of visual appeal are somewhat different for image files in colour and with other types of pattern. Nevertheless, the framing of complexity in terms of order and randomness is a useful descriptive tool, and one that is particularly appropriate for an objective measure of visual complexity which is based on image file compression. Despite the fact that this measure actually quantifies randomness instead of what we intuitively think of as complexity, it remains a practicable method for the investigation of visual complexity in contemporary art and design. In terms of the information scale of visual complexity, what we have learned may be summed up with Flake’s (1990) statement that “the interesting stuff is in the middle”:

‘Beauty’ i.e., that which makes something interesting, is related to a mixture of regularity and irregularity. When things are too regular, we usually find them to be uninteresting because they yield no surprises for us. Complementary to this, highly irregular things are often uninteresting because they make no sense. In the middle, between regularity and irregularity, lies a place where things can be understood, but not completely. (Flake 1990, p.411)

We have identified suggestions that randomness or chaos are perceptually less complex and less interesting than a mixture of order and randomness from contributions by Attneave (1954), Arnheim (1959), Berlyne (1971), Wolfram (2002), Gell-Mann (2003),

and Donderi (2006). However, empirical research into perceptions of highly complex and random images began only recently (Besner, 2007), and the validity of these claims is yet to be established. Thus there remains a gap in knowledge of the relationship between informational measurement and the perception of visual complexity.

# Chapter 3

## Approaching Visual Complexity in Art & Design

### Research Focus

The principal focus of this project is the aesthetic property of visual complexity. For practicality, the study is limited to the complexity of two-dimensional images in contemporary art and design practice. The project is largely situated within the discipline of fine art, but the scope of artwork under investigation includes two-dimensional visual material from a variety of creative fields, namely: photography, architecture, graphic design, illustration, decorative arts and textiles. For all these types of artefact, the research scope is limited to their aesthetic attributes only; it excludes an appraisal of the utilitarian functions of design and the interpretative aspects of art. In terms of Moles' (1966) distinction between semantic and aesthetic information, this project concentrates on aesthetic information, but the project also deals to some extent with semantic information via interviews with test participants to identify the criteria behind their aesthetic judgements.

The aim is to explore this subject via an empirical investigation into the aesthetic property of visual complexity. Justification for this research focus comes from the argument that an empirical study of aesthetics has the potential to complement the non-perceptual classificatory aesthetic definitions of art (see p.67). It can do this by providing an explanatory theory based on the measurement of perceived complexity and the information analysis of aesthetic images. Contributions to knowledge are made by extending computational aesthetic measures to the field of art and design, and by providing empirical evidence for a perceptual threshold in the informational spectrum of visual complexity.



The literature reviewed in the previous chapter serves to identify gaps in knowledge and to select the research methods appropriate for this investigation. The present chapter describes the methods and approach of this research project, beginning with the following section which outlines the research methodology that guides the choice of methods.

# Methodology

## Ontology and Epistemology

In the investigation of visual complexity, this project focuses on the relationship of objective properties to the subjective properties of perception. This constitutes a position of realist ontology, which can be expressed as follows: The belief in the existence of things external to our consciousness, and that the physical properties of those things are independent of how we perceive them to be. Those properties are also independent of the concepts that we employ in understanding them and the language we use to describe them. This project does not subscribe to the view that everything we know is based on socially-constructed language. Empirical evidence for the perception of visual complexity functioning partly at a pre-conscious level of perception (e.g. in the retinal processing of visual primitives such as edges, lines and blobs) is enough to reject that view. The social-constructivist position is a form of anti-realism (or ‘relativism’), which accepts the existence of external objects and events, but denies the independence of realist claims to knowledge about those objects. This project rejects this position and adopts a realist view.

The realist ontology of this project comprises *artist* and *audience* (subject), *artwork* (object) and *artworld* (context). These basic ontological categories provide a foundation for the project’s working model (Figure 6), in which the aesthetic is identified as the interaction of object and subject. Therefore, the objects of study in the current investigation are the physical properties that give rise to this interaction and the perceptual phenomena that result from it. The working model of aesthetics incorporates the ontology into the context of the practice and perception of art and design. Although the model was derived

independently of Dickie's art circle theory, Chapter 2 analysed the structural similarity of the two models. Their concurrence supports the validity of the ontological model in terms of its connection to contemporary understanding of art practice.

In the working model, the aesthetic is understood as the interaction between subject and object. The subjectivity of perception means that each individual has a unique perception of a particular object, and as such it is only indirectly accessible to knowledge. To say, "that is beautiful" is to ascribe a subjective value to an object. In this project's conception of aesthetics, such a statement provides a route to understanding the aesthetic interaction of subject and object. In other words, aesthetic interactions are phenomena which are subjective (i.e. private and individual), and therefore difficult to access, but which can be glimpsed through personal statements (that express one's perceptions) and artistic acts (that express artistic aims). Beyond the analysis of art and design objects themselves, it is these personal statements about subjective perceptions that form the objects of study in this research, since they are the most direct and accessible forms of aesthetic judgement available to an observer. Therefore, the epistemology of this project is not strictly empiricist in its philosophical position (i.e. it does not accept that knowledge is *only* derived empirically), but it is methodologically empirical because it is based on observation.

## **Problems with Empirical Aesthetics**

### **Philosophical Problems**

When Baumgarten coined the term 'aesthetics', it meant 'a *science* of aesthetic perception'. Wittgenstein said that a science of aesthetics is "almost too ridiculous for words" (1966, p.11), because "aesthetic questions have nothing to do with psychological experiments, but are answered in an entirely different way" (1966, p.17). Wittgenstein's argument is acceptable only if we admit that aesthetic questions are of a different kind to psychological questions. The opposing view is expressed by Daniel Berlyne, founder of the International Association for Empirical Aesthetics:

Whether a branch of study can be called scientific does not depend on whether it has yet answered its questions. It depends on what kind of questions it is asking and what methods it adopts in seeking answers to them. (Berlyne, 1971, p.2)

Berlyne's position is typical in modern psychology: what defines a field of science is not the type of question, but the way in which the question is answered – namely by the empirical method of accountable observations. A psychological question, therefore, is one that can be answered through the process of scientific method. For example, “does God exist?” is not a scientific question because it cannot be answered empirically – that is, we cannot reach a satisfactory answer by thoroughly exhausting all possible experimental attempts to provide evidence to the contrary. This is Karl Popper's (2002) concept of science, which says that only falsifiable hypotheses belong to the legitimate scientific domain. What this means is that science does not work by positive proof, but through lack of evidence to the contrary. A single counter-example is enough to rule out an experimental hypothesis, but unless and until one is found a hypothesis can become an accepted theory. Hypotheses are generated and then pruned away by systematically showing them to be wrong, eventually leaving only a few plausible explanations. By these criteria, “God exists” is not a scientific hypothesis because it is not falsifiable; we cannot provide evidence that God does not exist, and so the question remains beyond the scope of scientific method. A successful theory is thus falsifiable in principle, but not in practice.

The question “how long will I live?” could be answered with methods from astrology, religion, medicine, or statistics. The question is not scientific *per se*, but the scientific method is one among many possible approaches to an answer. From the set of all possible questions, therefore, scientific questions are the subset than can be answered empirically, and some of these may be answered in other ways. Insofar as the classification of a question as scientific depends on the nature of scientific method, it could be argued

that a science is characterised more by the methods it uses in answering those questions than by the type of questions themselves<sup>10</sup>.

Traditional aesthetic questions, whose answers remain in contention, include “what is art?”, “why do we value art?” and “how does art acquire its value?” These ‘big questions’ of aesthetics do not appear to be of the form that can be answered with scientific method, but other aesthetic questions are open to more than one form of methodical enquiry. “Which of these two paintings is better?” is an aesthetic question that can be answered empirically, by asking a number of people to state their opinion and analysing the results. Whether we are satisfied with such an answer, though, depends on our epistemological position. This project’s epistemology is outlined in the previous section, and does accept this form of answer as a route to developing understanding of aesthetic perception. The aim is not to reduce the aesthetic to a simple mathematical formula, but to enrich creative practice by understanding the causes and effects of visual complexity in art and design.

Dickie (1961) opposed empirical aesthetics, but I believe that his institutional theory of art can be supplemented with perceptual aesthetics. Dickie’s theory (1997) only describes the mechanism of the artworld, in an attempt to avoid the pitfalls of essentialist definitions of art which became problematic for philosophical aesthetics as art practices changed. The problem with the institutional theory is that it does nothing to explain why we value art. In an article in *Leonardo*, the psychologist Rolf Reber (2008) argues convincingly that empirical enquiry has the opportunity to add to understanding the

---

<sup>10</sup> It should be noted that there are also scientific questions that *cannot* be answered by science. For example, radioactive decay can be predicted accurately for a large number of atoms because collectively they obey statistical laws: For any radioactive material, the length of time it takes for exactly half of the atoms to decay is a constant period known as its half-life. But the question “when will a particular radioactive atom decay?” cannot be answered with anything other than a statistical probability. Similarly, there appear to be limits to the measurement of both the momentum and position of quantum particles, which is embodied in Heisenberg’s famous uncertainty principle. These examples reveal interesting limits to our knowledge as well as intriguing properties of our world.

perception of art, specifically that psychology can help to assess artistic value. Reber says that art theory and scientific method are able to integrate by empirically testing the criteria specified by art theories (e.g. whether the golden ratio is more beautiful), but warns that science is unable to evaluate the theories themselves: “psychology can determine artistic value, given a criterion, but not whether the criterion itself is a good or a bad one” (Reber, 2008 p.371). Ken Friedman also makes the case for an empirical approach to design, based on an understanding of aesthetics in the traditional meaning of sensory perception:

...the scientific approach to design does not contradict the artistic aspect of design. Successful design artifacts have aesthetic values and qualities, sensual and engaged. All designed objects, tactile, mechanical, visual, auditory, are mediated through the physical senses. Sensory quality is a central issue for articulate objects that work in a physical world. (Friedman, 1997, p.58)

Friedman’s argument for design science can also support this project’s empirical approach to visual complexity, since visual art is also mediated via the senses. Despite the evidence of a move away from perceptual aesthetics in the institutional theory of art and in the practice of relational aesthetics, there is no escaping the sensory foundation of aesthetic experience. Therefore, an empirical approach to aesthetics has the potential to inform understanding of contemporary aesthetic theory and practice and to fill the gaps in contemporary knowledge of the visual arts. In this context, the aim of the current project is to investigate just one element of perceptual aesthetics – visual complexity.

### **Practical Problems**

If we accept the empirical approach to aesthetics in principle, then we face problems with the approach in practice. Visual complexity is difficult to measure directly, since it is a property based on more fundamental attributes (quantity, variety and order). In addition, the subjectivity of perceptions causes difficulties for measurement because they are highly variable and inaccessible to direct observation. This is as much a problem for any other psychophysical study as it is in the case of visual complexity. For example, the estimation of hearing thresholds (equal loudness contours) suffers the same difficulties. The solution

to the problem of variability is to repeat tests and to average the results, whilst the problem of accessibility is solved using a method in which participants self-report their perceptions, namely Stevens' (1975) magnitude estimation scaling technique.

As an illustrative example of the current practice of standardisation in empirical aesthetics, I take from the literature reviewed earlier the PhD thesis *Complexity and Aesthetic Preference for Diverse Visual Stimuli* by Marcos Roberts (2007), who made the following adjustments to a set of images of artwork:

To avoid the undesired influence of psychophysical variables, all stimuli were adjusted to the same resolution of 150 ppi and set to the same size of 9 by 12 cm. Additionally, the colour spectrum was adjusted in all images. Values of extreme illumination and shadow in each picture were adjusted to reach a global tone range allowing the best detail. Stimuli were classified according to their dominant tone (dark, medium, or light), and those with a mean distribution of pixels concentrated in both the left (dark) and right (light) extremes of the histogram were discarded. Thereafter the luminance of the remaining stimuli was adjusted to between 370 and 390 lx. Stimuli that could not be reasonably modified in this sense were discarded. Finally, the signature was removed from all signed pictures. (Roberts, 2007, p.159)

Those digital images of artworks have been altered in size, proportion, content, colour, brightness and tonal balance. These are all fundamental aesthetic properties, and from an artistic point of view their alteration constitutes a mistreatment of the artwork. As a consequence, the validity of this approach is undermined. The attraction of 'ironing-out' these confounding variables is understandable from the empirical point of view because it makes the effects easier to detect and makes the analysis simpler. There are two arguments for preserving the integrity of stimulus images, however – one scientific (technical) and one artistic (moral), as follows.

The first argument is that in the case of experiments on aesthetic complexity, the treatment of artworks is a particularly sensitive issue, because by all accounts visual complexity is a function of a number of more basic visual properties, including those altered in the example above – namely size, proportion, resolution, colour and tone. The

literature review identified the quantity, variety and order of picture elements as the most fundamental attributes of visual complexity, and in the case of Roberts' (2007) experiments these have all been altered. In trying to measure visual complexity, it makes sense to minimise the alteration of properties to which objective measures and subjective perceptions of complexity are sensitive, because these alterations confound the experimental variables and weakens the ability to make inferences from the results of the test stimuli back to the original artworks.

The second argument for preserving the integrity of an artwork as a stimulus image is based on the moral principle that an artwork deserves respect in the same way as does its creator. The Copyright, Designs and Patent Act 1998 (CDPA) was introduced to enable artists and designers to control how their material is used. The fact that these rights are retained by the author even when the copyright of the work is transferred illustrates their significance. Provided that an experimenter has obtained licence to use the works in question, there should be no issue of authorship involving the 'right of paternity' (CDPA 77), but the treatment of an artwork for experimental purposes should respect the 'right of integrity' (CDPA 80, Appendix A). This is the right to object to derogatory treatment of the work, which may include "addition, deletion, alteration or adaptation" (DACS, 2008). To neglect this principle is to run the risk of undermining the value of the research, not only from the art world's point of view – for whom such research is potentially rewarding – but also in terms of experimental validity.<sup>11</sup> In conclusion, this project aims to minimise the alteration of artwork images in testing.

## **Methodological Approach**

The central aesthetic question of this project is: Does visual complexity contribute to the aesthetic value of art and design? The question cannot be answered directly through empirical methods, but its component parts can be tackled in this way with techniques

---

<sup>11</sup> I should add that I am not implying that Roberts (2007) has infringed copyright; I only mean to add weight to my argument by emphasising the seriousness of these principles for artists and designers.

from experimental psychology. The first step is to measure visual complexity and the aesthetic judgement of visual stimuli. The objective measure, based on image file compression, provides an informational scale of order to randomness that corresponds with classification schemes of complexity from systems theory (Wolfram, 2002; Langton 1990). This suggests research questions that can be answered empirically: How complex are examples of contemporary visual art and design? Is there a region of the informational spectrum of complexity in which these artworks tend to be found? What is the relationship between measures of objective informational complexity and subjective perceived complexity? Artworks appear to share a level of complexity with living things – both display a balance of order and chaos. Might we find that, like the preference for natural fractal values (Taylor, Micolich & Jonas, 2002), there is a preference for levels of visual complexity similar to those in nature?

To answer the research questions, this project employs a methodology with an integration of methods, both creative and empirical. The creative work explores methods of generating visual complexity, which has applications for both art practice and the empirical tests. One aim is to make artwork aiming for a particular level of complexity – the perceptual threshold of complexity hypothesized by Wolfram (2002) and Donderi (2006) – and then to test this experimentally by including this material in the test stimuli. The art practice also helps to guide the creation of visual stimuli for testing by exploring the computer as a ‘universal picture generator’ with programs such as cellular automata. After generating and collecting visual material, we can then perform empirical tests to measure the property of visual complexity and its perception in art.

The working model of aesthetics provides a structure for this project’s methodology. Since the model identifies the aesthetic in the interactions between an artwork and its artist or audience, the methodology focuses on these two sites of aesthetic production and aesthetic perception, and also on the artworld which forms the context of this research project. The plan is to approach these three areas of study – aesthetic production, aesthetic



perception and the artworld – by respectively making, measuring and mapping: Firstly, *mapping* aesthetic discourse with a contextual review of theory and practice identifies gaps in knowledge and guides the choice of methods. The contextual knowledge informs the *making* of artwork and visual stimuli for use in empirical tests. Finally, *measuring* the perception of visual material provides an empirical route to understanding the aesthetic judgement of visual complexity in art and design. The relationship of this methodology to the working model of aesthetics is illustrated in Figure 63.

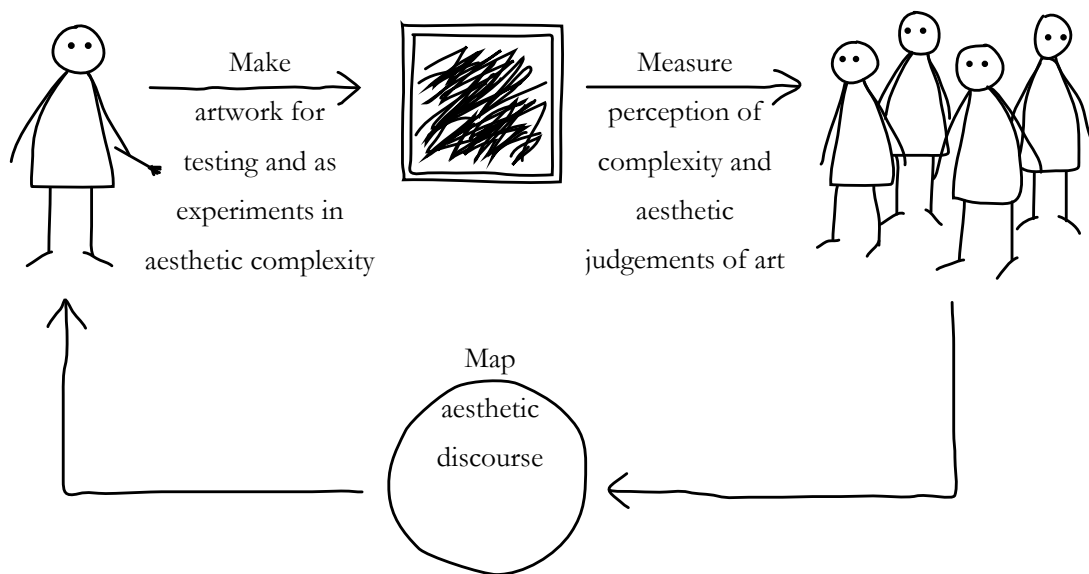

Figure 63 The methodology and the working model of aesthetics.

## Methods

The principal methods employed in this project are quantitative in nature. Their purpose is to quantify visual complexity through the measurement of objective aesthetic properties and subjective aesthetic perceptions. The aim is to investigate the correlation between these two measures over a range of visual complexity. To support this quantitative approach, however, the project also employs qualitative data collection and analysis methods. Through interviews with test participants we aim to establish, if possible, the criteria employed in making the aesthetic judgements in these tests – to shed light on the *how* that lies behind the *how much*. The following sections detail each of these methods.

# Quantitative Methods

## Measuring Objective Complexity

Donderi's (2006a) file-compression technique offers a practical solution to the problem of measuring visual complexity based on the identification of visual elements and the patterns they form: Pixels are the elements and data compression does the pattern-recognition. Digitisation provides a standard approach that can be applied to all 2D images. Making a digital version of an image involves a *quantization* of its visual information. In general, this means that information is transformed from continuous values to discrete values. In the case of digitization of images, the quantization process transforms the perceivable picture elements (e.g. patches of paint) into an array of pixels. The pixel thus provides the basic visual element in digital images, and it is the statistical properties of these elements that form the basis of the computational measure of visual complexity. We identified the fundamental properties of visual complexity as quantity, variety and order. These are also the fundamental attributes of digital image files; the quantity, variety and order of pixels are the properties that determine the size of the file after data compression. Therefore, in theory Donderi's file-compression method provides a theoretically-sound measure of visual complexity which also has empirical evidence for its success with radar and chart images (Donderi & McFadden, 2004) scenes of nature (Donderi & McFadden, 2005) and camouflage images (Besner, 2007). The current project applies this method to the aesthetics of art and design.

One advantage of the method is that in generating the digital image files to use as the basis of physical stimuli, we simultaneously implement part of its analysis. By generating compressed image files to start with, we have an initial indication of the objective complexity of the images. Once we have a set of compressed images, we can simply sort them in order of file size to get an idea of which are the most complex and which are the simplest. Most of the source images used in these tests are generated primarily as PNG files, whose compression algorithm gives the smallest files without data loss. This near-

optimum file compression means that the initial file size is close to the intended complexity measure, and saves space on the computer system. A problem is that in making digital reproductions of visual material, we introduce visual artefacts in the process by creating a discrete-valued representation of a perceptually continuous visual array. By using high-resolution scanning and printing, we can minimise the unwanted effects of this process.

### **Measuring Subjective Complexity**

The chosen method for measuring perceived complexity and aesthetic judgements is the psychophysical magnitude estimation scaling (MES) technique derived by Stevens (1975) and employed by Donderi & McFadden (2005). The method requires the participation of volunteers to engage in tasks, who for this project are recruited from staff and students at Nottingham Trent University, principally from the schools of psychology and art and design. By employing different groups of participants we are able to examine the effect of art experience on aesthetic perception and judgement of visual complexity. Conducting interviews with participants after the tasks also allows for qualitative data to be gathered which can add to the interpretation of the quantitative results.

The primary subjective aesthetic measure is perceived complexity. The other subjective measurements in this project are aesthetic preference (how much an image is liked) and aesthetic judgement of artistic quality (an evaluation of the artistic merit of a work). In this thesis, we abbreviate these two measures with the terms *preference* and *quality*. In effect, by investigating aesthetic preference and judgement of quality, we are getting close to what has traditionally been called beauty. Philosophical aesthetics classifies aesthetic preference as a judgement of agreeableness, and aesthetic quality as a judgement of taste. This aesthetic conception places aesthetic quality alongside the concept of beauty, whereas for those outside the field of aesthetics beauty would be usually associated with aesthetic preference rather than artistic quality. To avoid confusion in the tests, we use the terms preference and quality.

Since the nature of data to be collected is quantitative, it is appropriate to use statistical data analysis methods. Because we are looking for a correlation between objective complexity and subjective aesthetic judgements, we need to use statistical tools such as regression analysis which will tell us the strength and direction of the correlation. The details of these statistical methods are discussed in the following chapters as they are dealt with in the description of the test procedures and results.

## **Qualitative Methods**

### **Semi-Structured Interviews**

In order to see whether we can establish which criteria are employed in making the aesthetic judgements in the tests, the plan is to conduct semi-structured interviews with participants. Because the principal focus of this study is quantitative in nature, and also due to constraints in time and resources, these interviews are not to be conducted for every test, but only for the first part of the final test (Test 3a). The main objective is to determine the criteria in judging aesthetic complexity, preference and quality. The interviews also allow us to see how the participants coped with the task and offer them an opportunity to ask questions and comment on the experience. This data is recorded as audio files, and later transcribed for qualitative analysis, as described in the following section.

### **Transcription Coding and Analysis**

A principal difference between the quantitative data gathered in the main tests and the qualitative data gathered in interviews is that the former relates to *objects seen* whilst the latter concerns *events heard*. Another difference is that the quantitative data relates to the perception of aesthetic information, whilst the qualitative data deals with semantic information. This requires a fundamentally different approach to analysis, because we are dealing with semantic information rather than aesthetic. Content analysis is the broad heading under which this type of analysis falls, and in this study we focus on transcription coding as the principal method. Krippendorff (2004) describes three approaches to content analysis, based on three different understandings of how the content (meaning) is identified

in the process of analysis. The first of these positions comprises the belief that the content is inherent in the transcribed text – the content is simply ‘there’ on the page to be discovered. The second regards the content as a property of the source of the text, namely the interviewee, and accepts the fact that there is an element of uncertainty in the transcription process. The third approach goes yet further by acknowledging the role of the researcher in actively constructing the content of the interviewees’ words through the process of transcription and analysis. In terms of the diagrammatic representation of qualitative analysis in Figure 64, the first approach focuses only on the text and disregards the other elements; the second also includes the interviewee as the source of the text; the third approach incorporates all three by recognising the role of the researcher in transcribing and analysing. This project adopts the third approach to content analysis.

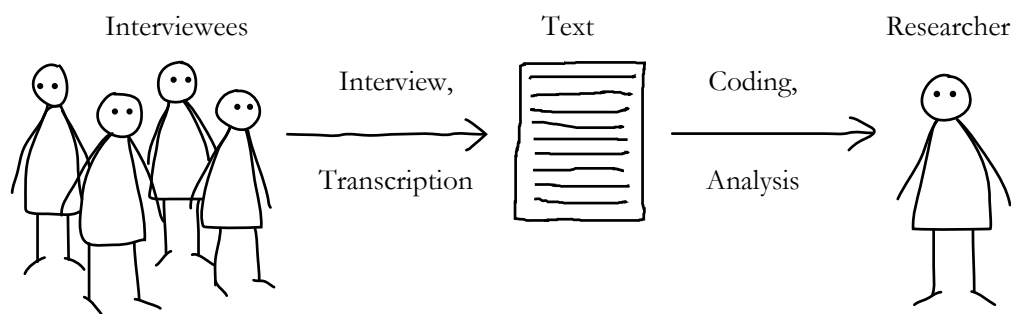

Figure 64 Representation of the qualitative analysis process.

Amongst the various methods of content analysis, this project focuses on a form of transcription coding as the main method of analysing the qualitative data gathered via the semi-structured interviews. According to Saldana (2009), the process of coding identifies a data set’s primary content by reading and interpreting (*de-coding*) as well as identifying and labelling (*en-coding*): “coding is the transitional process between data collection and more extensive data analysis” (Saldana, 2009, p.4). The main concerns of this analysis are to enumerate and categorise the various responses to the interview questions and to determine through a basic statistical analysis their frequency and significance.

## Plan

The literature reviewed in the previous chapter reveals that although visual complexity has been a subject that dates back to the beginnings of experimental psychology, there have been few attempts to study the entire range of visual complexity. The reason for this may be that it is difficult to achieve, because it is not easy to create such a range of stimuli and also because the analysis required gets more complicated with more complex stimuli. Looking at the whole spectrum allows for a useful preliminary overview of the phenomenon and provides a frame of reference for further tests. Therefore, this is the aim of the initial tests in this project. The proposal for test 1 is to generate a series of images that represent equidistant samples along a scale of objective complexity as measured by file compression. In this way, we are able to generate a series of images that cover the four classes of complexity identified by Wolfram (2002), namely: uniform, repetitive, complex and chaotic.

The plan is to start with limited variables and increase them gradually in successive tests. Test 1 begins with low-resolution black and white images (that is, with only 2 varieties of picture element) in order to be able to focus on order/arrangement of elements. The stimuli are generated from cellular automata and random programs. In terms of the quantity, variety and order of picture elements: the quantity is fixed at a fairly low value (one million pixels) and the variety is low (just two different types – black and white) while we manipulate the order of pixels. Test 2 increases the overall complexity of the stimuli by increasing the quantity and variety of the picture elements: The CA and random images have up to four colours with a resolution of just over 4 million pixels (with dimensions  $2048 \times 2048$  pixels). Finally, test 3 uses images of art and design artefacts scanned at high resolution (around 35 million pixels) and with full colour (using RGB colour space, up to 16 million colours). Test 3 takes place in two locations – the psychology laboratory and the art gallery – which are presented as tests 3a and 3b respectively.

The relationship of the chosen methods to the structure of this project can be illustrated by reference to the working model of aesthetics. Figure 65 shows how the methods relate to the model. On the side of aesthetic production (between *artist* and *artwork*), the method is to make and collect visual material for use in the tests. The test design is informed by the mapping of current practice (in the *artworld*) via the contextual review. The tests use two methods to measure visual complexity: Objective complexity (of the *artwork*) is measured with the file-compression method, and subjective complexity (the perception of the *audience*) is measured with the MES method. The perceptions of the participants are further elaborated through interviews and qualitative analysis. In this way, the methodology approaches both sides of the aesthetic in the model – aesthetic production and aesthetic perception, whilst the methods investigate both objective and subjective aesthetic properties of visual complexity.

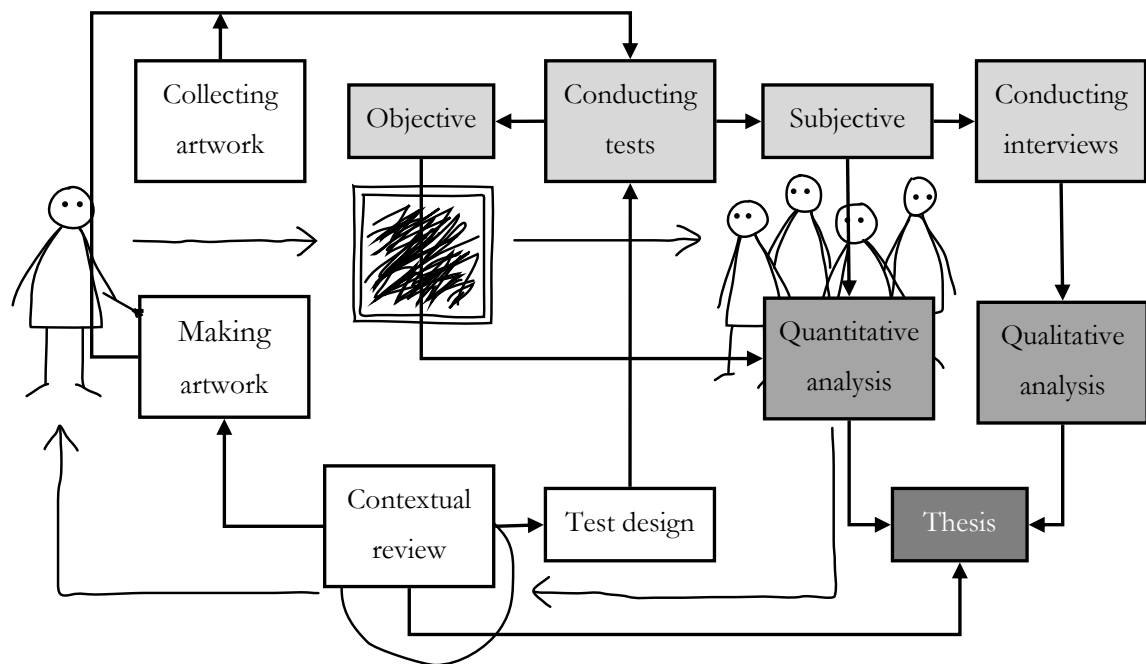

Figure 65 Diagram to show how the methods relate to the working model of aesthetics.

# Chapter 4

## Investigating the Spectrum of Visual Complexity

### Trial 1: Objective Measure

Phase one of the method trial examines the objective measure of visual complexity. We use Donderi's (2006a) measure of image complexity on images of Wolfram's 'elementary' cellular automata (eCA). Using CA images has a few benefits: Firstly, it offers a convenient method of generating manipulable stimuli; it is relatively easy to generate these images in any colours or dimensions. Secondly, we can be confident that the images represent a wide range of complexity (as mapped out by Langton and Wolfram), and the relatively small number of eCA rules means that we can produce images of all of the 256 patterns in this type of CA. Lastly, it makes for an easy comparison of results against the findings of Wolfram (1984) and Langton (1990). Using CA as test stimuli also has the advantage of providing images that avoid the confounding factor of familiarity (Forsythe, 2008), since these types of pattern are not widely known to the general public and are scarcely seen in contemporary visual art.

A set of all 256 'elementary' cellular automata is generated by writing a *Mathematica* program. The eCA images have just two colours (black and white) and each has dimensions of 100×100 pixels. The compressed PNG image files range in size from 96 to 1,500 bytes. Figure 66 shows the set of images arranged in order of their rule number, from 0 at the top left to 255 at bottom right. With this type of CA, there are many more regular patterns than random ones, therefore some pattern types are over-represented in this set. In subsequent tests, a selection of CA stimuli is made by sampling from equidistant points along the range of file sizes, avoiding the duplication of similar images.



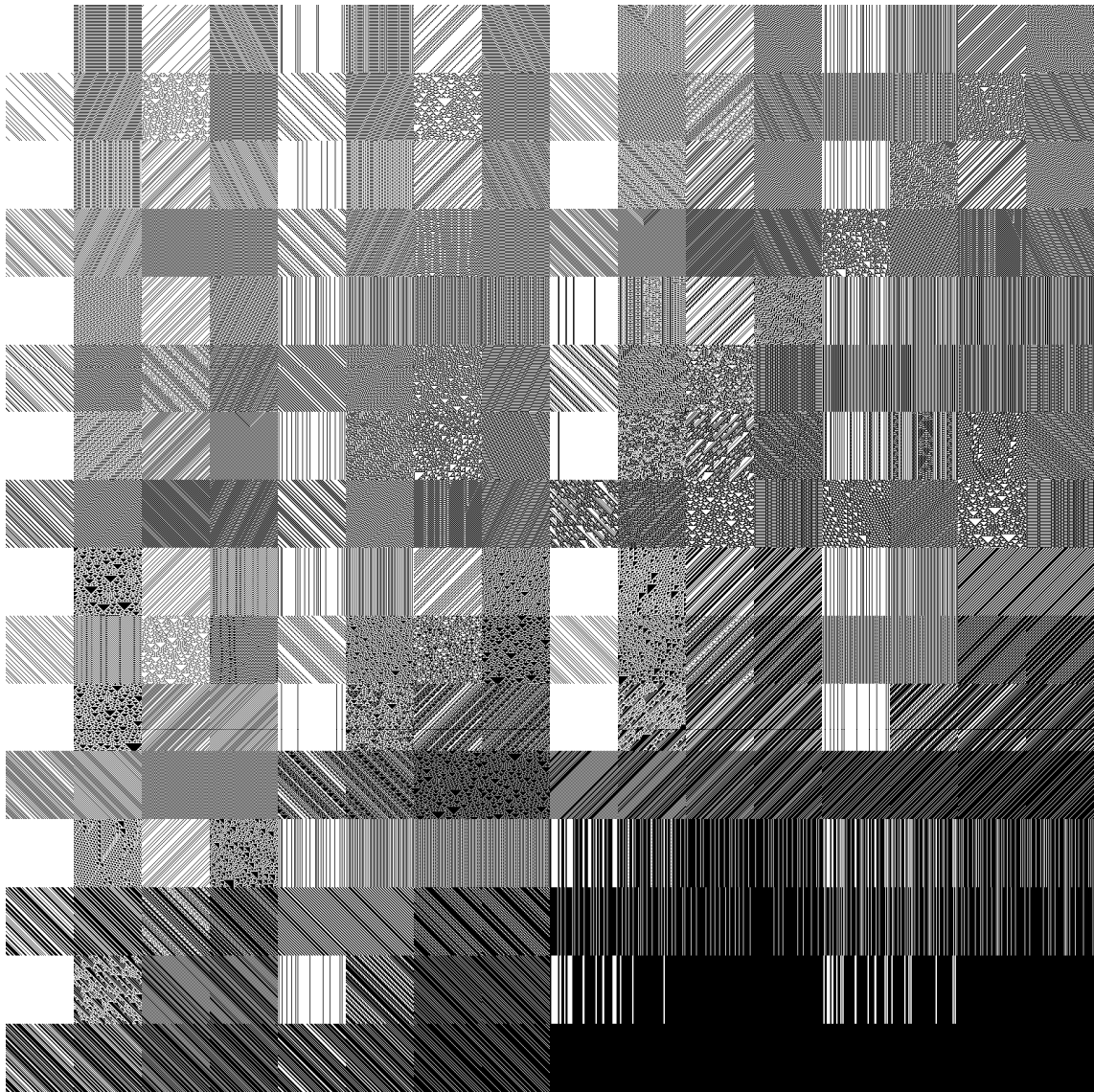

Figure 66 Images of all 256 elementary cellular automata, sorted by rule number.

When the set of compressed image files is sorted by size, the result is the arrangement shown in Figure 67. It is readily apparent that the clustering of image types mirrors Langton's arrangement of Wolfram's four complexity classes: The simple, uniform images come first,<sup>12</sup> followed by increasingly complex repetitive patterns, and finally the most random images are found at the end. Between the regions of order and chaos are a few complex images that have elements of order and randomness.

---

<sup>12</sup> It seems that the reason for black images coming before white is a quirk of the sorting system because both black and white uniform images are 96 bytes (768 bits) in size. These are all bi-level images, which use only one bit per pixel to store colour information, and so it takes no more information to store 'white' than 'black'.

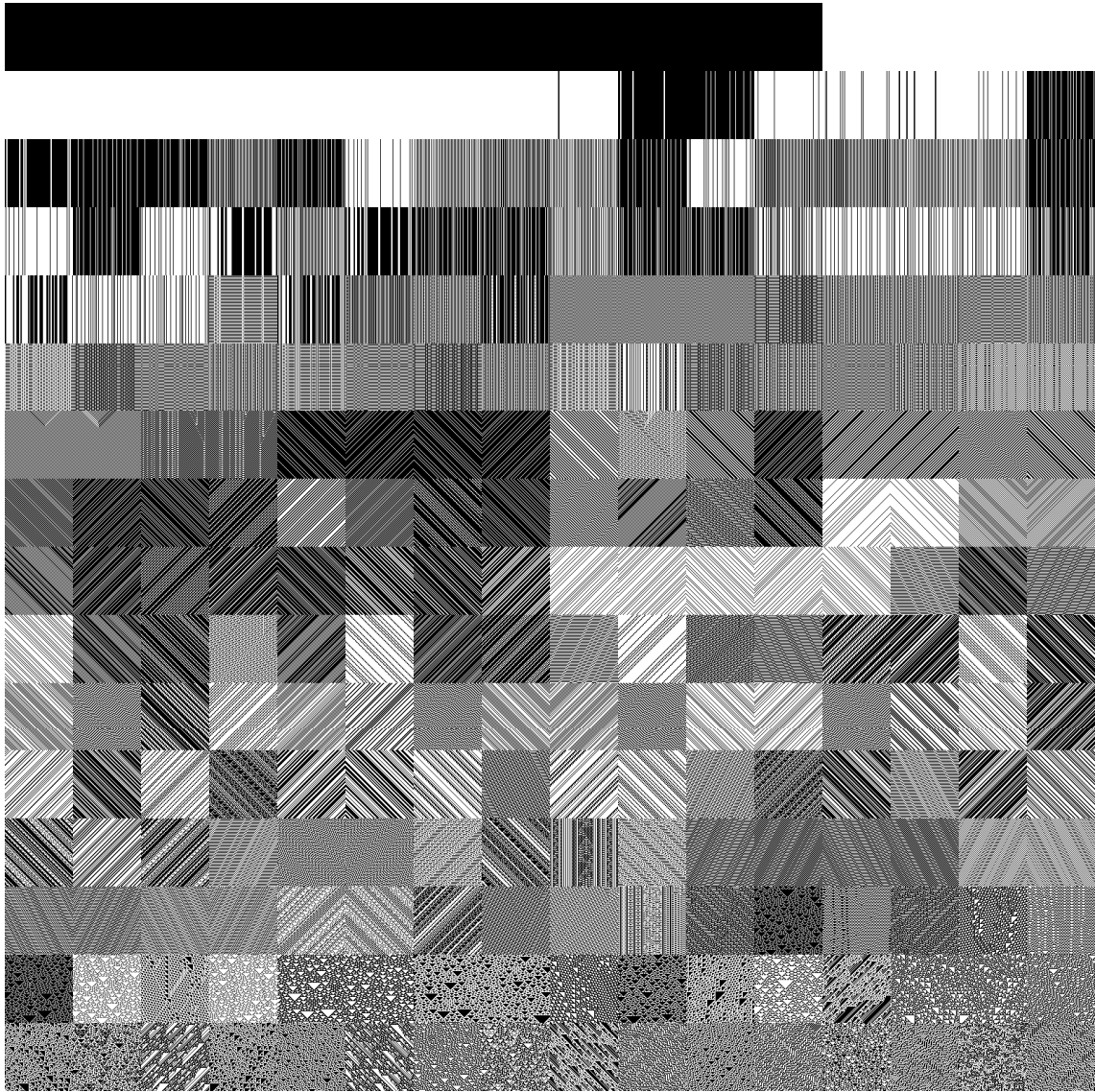

Figure 67 Images of all 256 elementary cellular automata, sorted by file size.

Note that the images with the largest size are fairly smooth in texture, whereas the more lumpy-looking images are those between the regions of order and chaos. The lumpy ones look like that because they have a greater number of different patterns than the other images. If we judge the complexity of images by the size of their description, as we said earlier, then these lumpy-looking images are the most complex. Because these images contain some regularity as well as randomness, they do not produce the largest files, since a regular pattern is compressible. The file-size measure is in agreement with Wolfram's classification and Langton's ordering, but because of this we also see how the measure is similarly inconsistent with our intuitive understanding of visual complexity.

In one sense this result is trivial, since it could have been predicted by anyone who understands image file compression. On the other hand, it is surprising to see such a close match between different schemas from experimental psychology and complexity science. As far as the literature review reveals, this trial is the first time that data compression has been used as a measure of cellular automata complexity, and provides the first direct link between the information-theory measure of visual complexity and Wolfram's (2002) and Langton's (1991) complexity schemas. As such, it may constitute a contribution to knowledge, though the potential application of this finding is as yet uncertain.

What links the complexity schemas with the file-compression measure of complexity, and explains the result of this trial, is the concept of order as developed in information theory (Shannon, 1948). What this means is that the objective measure of visual complexity is actually a measure of randomness (or 'entropy' as Shannon called it), and is not necessarily a measure of complexity as we perceive it. This might not be a problem for the current investigation, though, since it still provides a practicable method which not only accords with models from complexity theory but which is also robust and clearly understandable. It also supports the idea that complexity can be understood as a mixture of order and randomness, since we find the most complex images between these regions. Nevertheless, the implication is that the correlation which Donderi found between file size and perceived complexity may break down for the most random images. This suggests two things: Firstly, that Donderi & McFadden (2004) only looked at relatively simple images, for which the correlation is strong because there is agreement between informational and intuitive measures of complexity for the lower part of these scales. Secondly it provides a reason for investigating a wider spectrum of visual complexity in order to resolve this concern and to contribute to the field by extending research into this area. In conclusion, we have validated the objective measure of visual complexity and discovered significant issues which will bear on the interpretation of subsequent test results. Next, we look at the use of cellular automata images in the measurement of perceived complexity.

## Trial 2: Subjective Measure

To check that cellular automata images are feasible to use as test stimuli for subjectively perceived complexity we performed an informal test. Sixteen black and white images of cellular automata patterns, chosen from the set of 256 used in the previous trial, are selected to represent a range of complexity. The images are printed on A4 paper and laid out randomly on a table top. Five people (three PhD students and two members of staff from the School of Art & Design) were tasked with arranging the images in order of perceived complexity by physically laying-out the images in sequence. Figure 68 shows the averaged results.

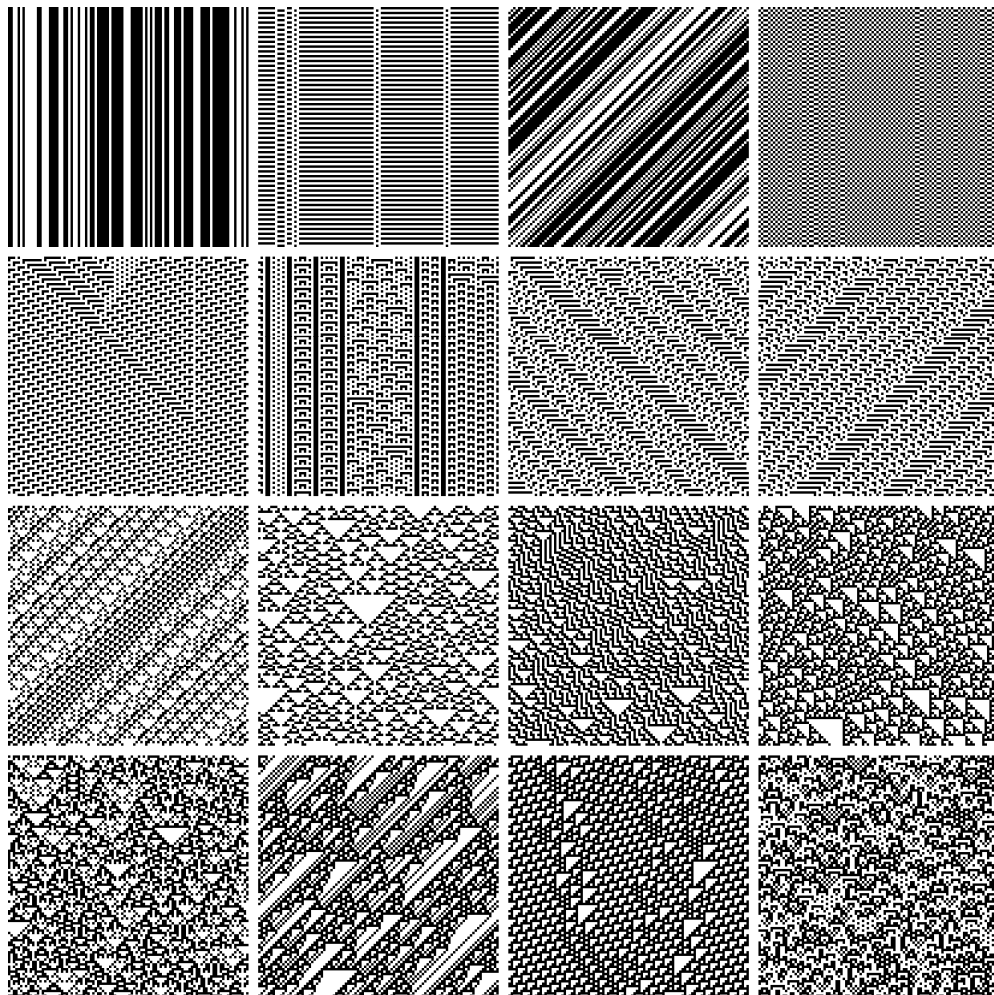

Figure 68 Image set used for the trial of the subjective measure, sorted in order of increasing perceived complexity from top left to bottom right.

The results are encouraging because in general the images were sorted in an order that approximately matches the sequence of complexity classes found in the previous trial. The biggest disagreement between individuals seems to be with the chaotic images – some thought that those were the most complex and others thought they were much simpler – but in general the ordering of the images was fairly consistent in terms of the placement of various complexity classes and their types of pattern.

One drawback of measuring perceived complexity by rank order is that the type of data it provides only tells us which images are perceived to be more complex than others; it cannot tell us whether any two images are perceived to be near or far apart on a scale of visual complexity (for example, images ranked in first and second place may actually be farther apart on a scale of complexity than their rank order might suggest). To address this issue, we need an alternative method which provides a ratio scale in place of an ordinal scale of numbers, which allows for a more sophisticated statistical analysis. For example, with ordinal scales, certain useful statistical tests are prohibited – such as the mean and standard deviation. These tests are required in order to be able to calculate the statistical correlation between the objective and subjective measures of complexity, as in Donderi and McFadden (2005). Although this method's trial is an informal test procedure and lacks a thorough statistical analysis, the results are promising and they provide a basis for continuing the investigation towards a more formal analysis. The following test uses the same type of CA image with greater resolution, and uses a technique for the subjective measure of complexity that provides a more sophisticated ratio scale of measurement.

# Test 1: Monochrome CA and Random Images

Donderi and McFadden (2005) found that the compressed file size of digital images is an indicator of subjective ratings of complexity for certain images. The previous trial of measures suggests that the correlation may apply to non-random images only. The present test aims to explore whether this correlation holds over a wide range of objective complexity, from simple order to random patterns. The contextual review in Chapter 2 reveals that studies in empirical aesthetics rarely attempt to investigate the full spectrum of complexity, but that in fact this might be a useful exercise. Looking at the whole range provides a valuable overview, especially for mapping the subjectively perceived complexity of CA images in relation to established schemas of objective complexity. It also enables us to see whether or not the correlation between objective and subjective complexity breaks down for random images, as suggested. If it does break down, then Donderi's claim must be qualified with a statement of the range of visual complexity to which it applies, but it is only by investigating the whole spectrum of patterns that we can establish with confidence which regions of complexity we are dealing with. If we know where the end-points (minima and maxima) of the scale are, then we can measure more precisely the subjective perception of visual complexity in relation to the schemas of Wolfram and Langton, which are based on the objective properties of CA images.

## Method

In this test, we use Donderi's file compression and MES technique to gather estimates of objective and subjective complexity. By sampling from the whole spectrum of complexity, we are able to build up a picture of the perceptual response to an objective range of visual complexity based on an informational scale of measurement. Lastly, we use statistical analysis to determine the correlation between the two measures. These quantitative results are presented as graphical representations of how perceptions of complexity vary across a wide range of image complexity.

## Participants

For convenience, the subjects in this test are Master's students in the College of Art & Design and the Built Environment at NTU. It was decided to select half from Fine Art and half from Construction Management courses, as those groups represent the most and least trained in art at that level of study. The selection is designed to reveal the influence of art training upon the aesthetic judgements being measured. Eight subjects are selected by canvassing the students and accepting the first four volunteers from each course. One student from Construction Management dropped out, and an art-trained member of staff performed the eighth test. All but one of the subjects were women.

## Materials

The test stimuli comprise two sets of 25 black and white images printed at 265×265mm on A3 cartridge paper. All images are composed of one million (1000×1000) black and white pixels and surrounded by a thin mid-grey border to delineate the edges of each image against the white paper. At the printed resolution (approximately 96ppi), individual pixels are just recognisable seen at close range, being just over a quarter of a millimetre square. The image sets were created with *Mathematica* programs, one set being made with cellular automata (Figure 69), and the other from random processes (Figure 70).

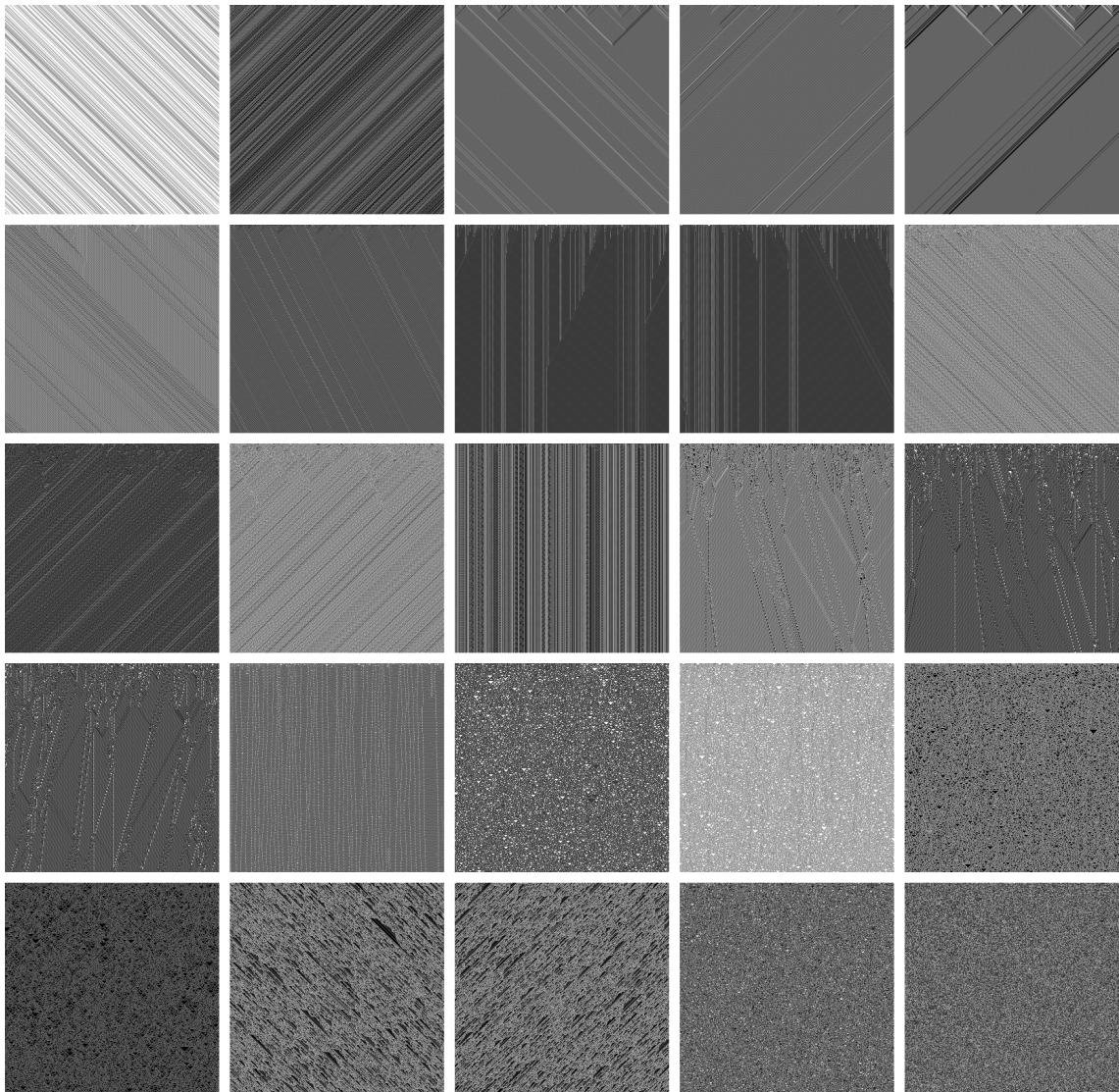

Figure 69 Set of 25 cellular automata images, sorted in order of increasing file size (from top left to bottom right).

The random images are designed to show a similarly wide range of detail as the CA images, but with different shapes. They were made by starting with images in which each cell is randomly assigned the colour black or white. Next, the image is blurred by a small amount with a Gaussian function, which introduces shades of grey, and then a threshold filter applied, which changes each pixel to black or white again based on whether its grey level is above or below the midpoint. This has the effect of pooling black and white areas, depending on their average tone. Each random image has different amounts of blurring applied, with the same threshold filter. The visual effect of increased blurring in this



process is similar to that of water condensing on the side of a cold glass – tiny droplets form initially which gradually draw together to form increasingly large beads (Figure 70).

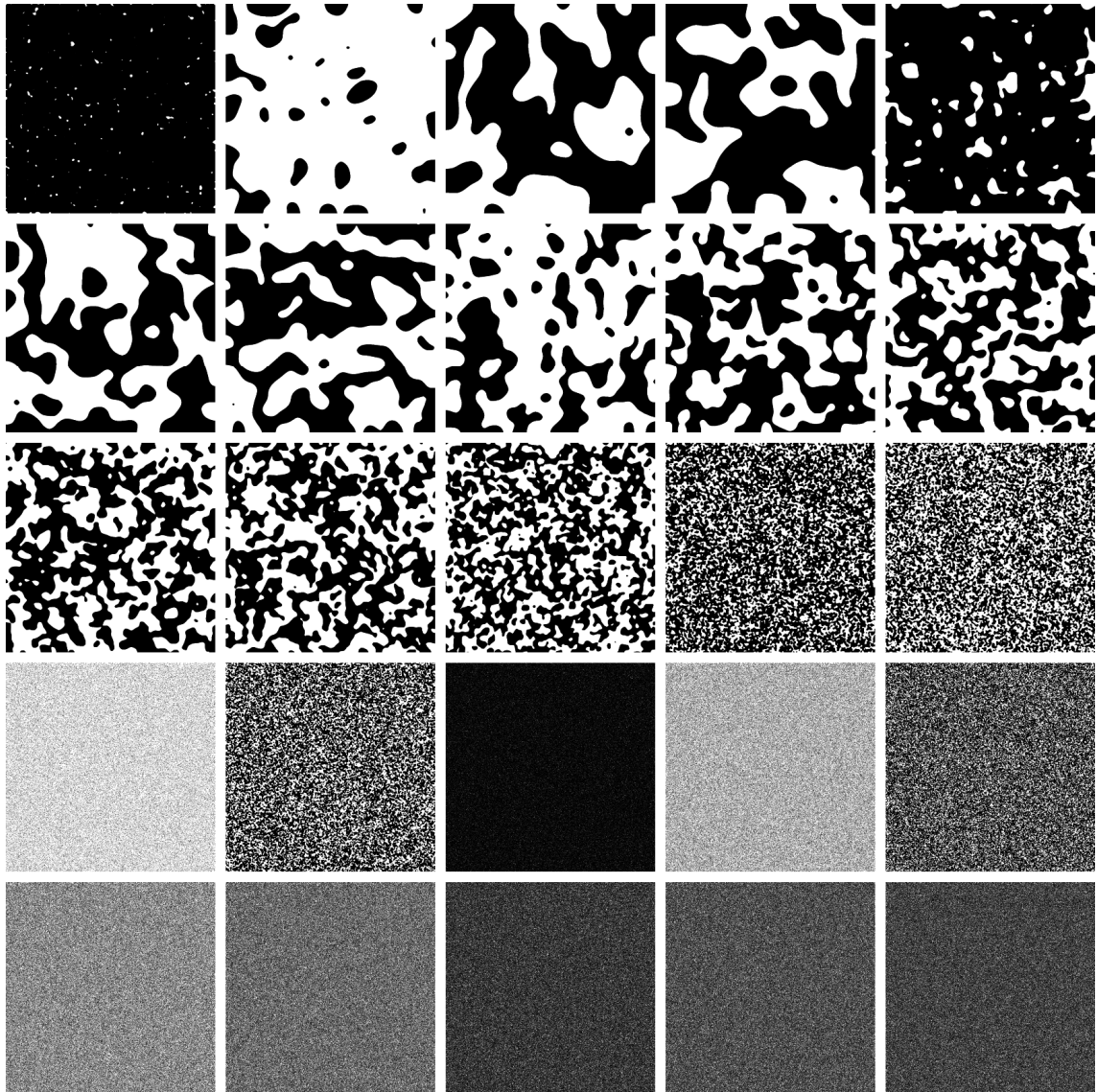

Figure 70 Set of 25 random blob images, sorted by increasing file size (top left to bottom right).

A large number of each type of image was generated with programs written in *Mathematica* and then converted to maximally-compressed PNG files using the freeware graphics software *IrfanView* (Skiljan, 2009) together with Ken Silverman's (2006) PNGOUT plug-in, which enable batch-processing of image files and near-optimum compression, respectively. PNG was chosen as the file type for measuring objective complexity as it produces the smallest files for this type of bi-level image (Salomon, 2004).

Pairs of similarly-sized files of cellular automata and random images were selected to range from the smallest to the largest, to make two sets of 25 images that covered a similarly wide range of objective complexity.

## **Procedure**

Participants rated images for preference and complexity using the method of magnitude estimation scaling, whereby numbers are assigned to reflect the strength of perception. Tests were conducted in a well-lit room with only the investigator present, except in one case where two participants were tested concurrently. Verbal and written instructions informed the subjects of their task (see appendix A), and a practice run with a small set of different images was conducted before the tests began in order to familiarise the participants with the procedure. Participants were given the opportunity to ask questions and testing began only when they reported they were comfortable.

Each participant rated each of the two sets of images twice over – once for preference and once for complexity, so a test comprised four sets of 25 ratings. The order of images presented in each run was randomised. The small number of participants meant that not all of the possible 24 sequence permutations could be used, so the order of tasks was balanced between subjects, with each task being performed in equal rank frequency. Rating types were grouped together, with half the subjects rating complexity first, and the other half preference first. The printed images were presented in sets stacked in randomised order, and the participants turned over the top sheet to reveal the next image once they had recorded their rating by writing on a numbered score sheet. It took on average half an hour to rate the four sets of 25 images. After the task, participants were invited to comment on the tests.

## **Results**

Because this is the first of three empirical studies in this project, the present section focuses more on evaluating the viability of methods and determining the subsequent direction of later tests. The most important issues are to correctly interpret the results, to

validate the suitability of research methods, and to identify how to proceed for the following tests.

The data for all eight participants' sets of four ratings are shown in Figure 71. This figure provides a general illustration of the kinds of differences between individual ratings rather than a precise statistical analysis. Nevertheless, the numerical scales upon which the data are represented are the same for each plot, so the display accurately reflects the relative values collected. Each graph is drawn to the same scale, showing increasing rank order of image PNG file size (3 to 123 kilobytes) from left to right on the horizontal axis, and subjective ratings (of the range 0 to 35) on the vertical axis. The top 3 rows are responses from Construction Management students and the rest from Fine Art, with all except the top row being women. The diagram is an attempt to follow Tufte's (2001) principles of information visualisation, with an economical, accurate and elegant presentation of the salient features of the data set without clutter and extraneous detail.

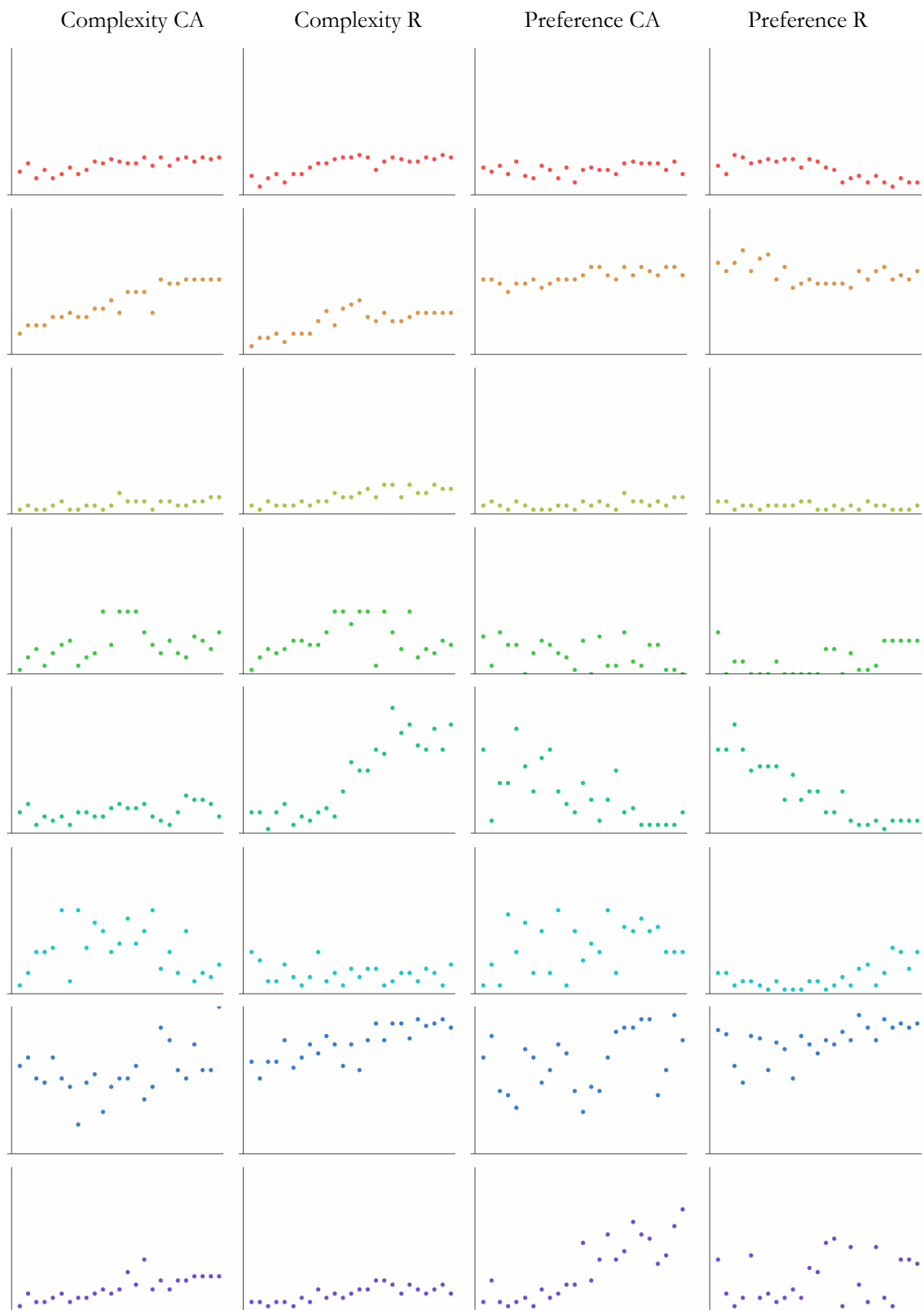

Figure 71 Complete set of un-adjusted subjective ratings (in labelled columns) for participants 1 to 8 (coloured rows, in test sequence from top to bottom) in Test 1.

It is testament to the effectiveness of our visual system that an illustration such as Figure 71, which contains a total of 800 data points, provides a more comprehensible statistical description than an equivalent table of values. Provided we know what it is the diagrams illustrate, this most basic of statistical descriptions, the scatter plot, shows with clarity any trends in the patterns of data, such as their dispersion, slope or range.

From these scatter plots, we can already see that there does appear to be a positive correlation between objective and subjective measures of complexity (as one increases, so does the other), and that the correlation with preference is more variable (there are some upward and some downward slopes). This variability in individual trends means that we should be cautious about statistical analyses based on averages of these distributions. For example, if half the subjects showed a positive correlation and half negative, the averages would produce a result of zero correlation, which is statistically correct but less useful than the more detailed overview in Figure 71.

### **Data Transformation**

There is more than one type of variance in this data, however, and depending on the type of procedure employed, some of them are trivial and some are not. Non-trivial variance is expressed in the difference between an individual's ratings: Larger numbers mean greater complexity, and we should not alter the data in a way that affects this property. But the difference in the *range* of numbers between subjects is less important. To explain, imagine a situation where ratings by two participants differ only in that in one set each value is exactly twice as large as in the other. It might seem appropriate to transform the data to make it comparable. In this test, the lowest and highest values used across all subjects are 0 and 35, while the smallest and largest ranges used are 3 (1 to 3) and 30 (1 to 30). What we want is to make the ranges closer together so they can be compared. The assumption behind these data transformations is that the range of subjective impressions is approximately equal, even if subjects use different ranges of numbers to represent their perceptions. However, Stevens' (1975) method of magnitude estimation also assumes that

the subjects' scale of numbers is a *ratio scale* (i.e. a scale incorporating a zero point, where numbers express ratios, so that '3' means 'three times larger than 1'). Because of this assumption, the only permissible transformations are those that preserve the property of rationality. In this test, we use the mean logarithm of the scores, and in subsequent tests we use the geometric mean, which is a similar type of transformation.

Figure 72 is a graphical representation of the effect of various types of transformation on the subjective ratings (note the varying scales of the  $y$ -axes). If the raw data (Figure 72a) were transformed by treating each subject's lowest and highest values as equal – making each maximum 1 and each minimum 0, we would destroy the property of rationality, because the zero points are moved: Figure 72b shows that each subject's graph line is stretched vertically to make it touch the top (the value 1) and the bottom (0). In experimental psychology, a common way of dealing with this type variance in scales is to use the logarithm of the values – a transformation which retains the rationality of the scales relative to zero, and does not alter the relative positions of the data. The logarithm transformation (Figure 72c) does not make each scale exactly the same, but it transforms them to similar ranges and enables averaging of data. Because the logarithm of zero is infinity, data containing zeroes must be altered before the log transform by adding a small number. Figure 72d shows an alternative – the square root, which seems to offer a viable alternative to the logarithm transform. For this test and subsequent tests, the logarithm transform is selected, because it fulfils the necessary criteria and is the same technique employed by Donderi (2006a).

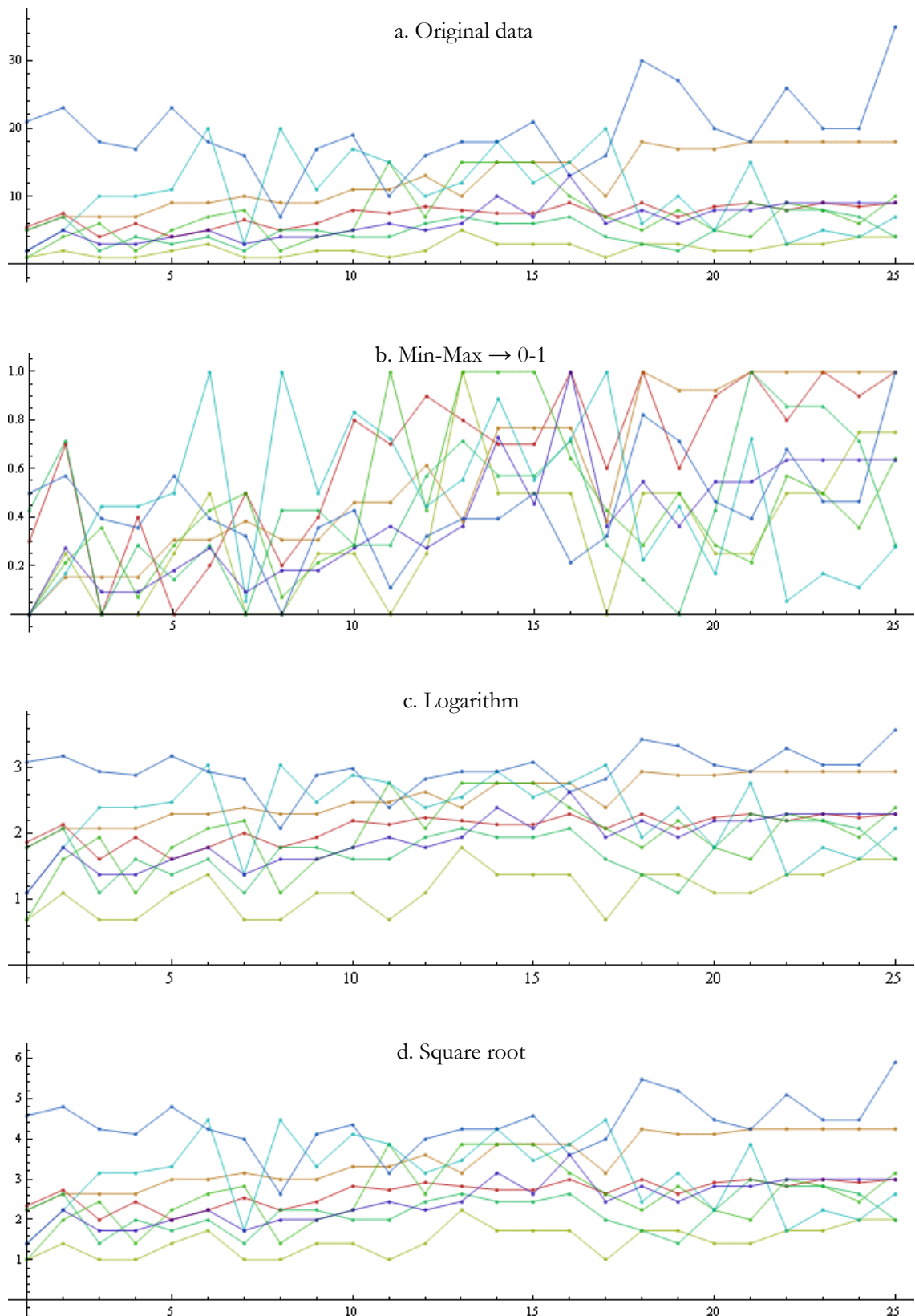

Figure 72 Visualising the effect of various data transformations. All graphs represent the data for subjective ratings of complexity ( $y$ -axis) for CA images against rank order PNG file size ( $x$ -axis). (Cf. first column of Figure 71, above, and Table 1, below).

## Analysis

After the data has been suitably transformed, we can perform calculations that tell us how closely the trends of the subjective data match the trends of the objective measures, that is, the *correlation* between them. According to a standard text on statistics for psychologists (Howell, 2007), the most common form of correlation, and the appropriate method to use in this case, is Pearson’s product-moment correlation, which is expressed as an *r* value – a measure without units that can range from -1 to +1. A positive value indicates a correlation in which one variable increases with the other, a negative value indicates a variable that decreases as the other rises, and a value close to zero means that there is little correspondence between the two. Table 1 shows how the data transformations in Figure 72 affect these *r* values (the first column corresponds to the graphs in Figure 4).

Data Transformation	Mean Complexity		Mean Preference	
	CA	Random	CA	Random
None	0.700	0.827	0.571	-0.086
Min-Max → 0-1	0.717	0.778	0.621	-0.056
Logarithm	0.680	0.753	0.515	-0.034
Square root	0.651	0.781	0.468	0.028

Table 1 Influence of various data transformations of subjective ratings on correlations with PNG file size.

It looks like the ‘worst’ transformation (Min–Max → 0–1) gives the ‘best’ correlation, but this should not mislead us into thinking that it is the correct one to use. The most important aspect of the *r* values in Table 1 is not the minor differences between data transformations, but their similarity. It tells us that there is a strong correlation between subjective and objective complexity for both image sets, and that there is a weak correlation between file size and preference for the CA images. There is almost no correlation with preference for the random images, but we noted earlier that actually there



are almost equal numbers of negative and positive correlations amongst the subjects, which therefore cancel each other out in these statistics.

The most important aspect of the  $r$  values in Table 1 is not the minor differences between data transformations, but their similarity. It tells us that there is a strong correlation between subjective and objective complexity for both image sets, and that there is a weak correlation between file size and preference for the CA images. There is almost no correlation with preference for the random images, but because there are almost equal numbers of negative and positive correlations amongst the subjects, they cancel each other out in these statistics.

### File Types

Image file types differ in the way they handle pictorial data, and use various methods of encoding and compression, so the file size of a given image will vary from one type to the next. It is likely that nearly-optimal compression is a favourable condition for correlation with subjective complexity ratings, but no one has yet undertaken an exhaustive trial of the different image file types and compression methods for this purpose, so it remains to be seen which is best for this job and why. This matter cannot be fully explored in the present study, but the results should be able to give an indication of the relative performance of various file types. The correlation of five different image file types with subjective ratings is shown in Table 2:

File Type	mean(log) Complexity		mean(log) Preference	
	CA	Random	CA	Random
<b>PNG</b>	0.608	0.740	0.404	-0.045
<b>JPEG</b>	0.547	0.813	0.118	-0.155
<b>TIFF (LZW)</b>	0.607	0.717	0.294	-0.038
<b>ZIP (PNG)</b>	0.607	0.741	0.404	-0.060
<b>ZIP (JPEG)</b>	0.644	0.806	0.415	-0.152

Table 2 Correlation ( $r$  values) of subjective ratings and file size for various file types.

What is most apparent in Table 2 is the general agreement amongst file types, with much stronger correlations for complexity ratings than for preference. Donderi and colleagues found the best correlations with lossless JPEG images compressed as ZIP files, and that is also the case here (N.B. ZIP is not an image file type, so it cannot be used to display graphics – it is used by Donderi to provide a second process of compression.) PNG was chosen as the working file type for creating the stimulus images because they gave the smallest files, and JPEG and TIFF were selected for the test because they are commonly used in graphics applications. ZIP files were made of uncompressed PNG images and lossless JPEGs.

Lossless JPEG had to be used because lossy compression was found to degrade the images by producing greyscale artefacts which blurred their crispness, and this would have made for an unfair comparison with the other image types. JPEG was expected to perform poorly in this study as an indicator of subjective complexity because it is known to give poor compression ratios for bi-level (black and white only) images. Actually, it shows the weakest correlation with the CA images, but the strongest for the random images. This could be explained by the fact that JPEG encodes two-dimensional regions of image data, unlike the other file types here, and so the ‘blobby’ nature of the random images is captured more effectively than the intricate CA images. This is also reflected in the difference between the total sizes of image sets using different file types (Table 3).

File type	Size of image folder (MB)	
	CA	Random
<b>PNG</b>	1.26	1.36
<b>JPEG</b>	24.9	14.0
<b>TIFF (LZW)</b>	2.07	1.72
<b>ZIP (PNG)</b>	1.18	1.21
<b>ZIP (JPEG)</b>	16.5	13.6

Table 3 Total sizes of all 25 images in each set for various file types.

The difference between the folder sizes of PNG and ZIP (PNG), together with the similarity of their  $r$  values in Table 2, indicates that the type of image encoding, rather than the compression method, which most affects the rank-ordering of images and their subsequent correlation with subjective ratings (these two file types share image-encoding methods, but use different methods of compression).

### Preference and Complexity Ratings

Table 4 shows the relevant correlations between subjective ratings. There are weak correlations between preference and ratings of complexity for both the image sets, but they differ in direction: For the CA images, preference increases with complexity, but for the random images it decreases, meaning that the participants preferred the more complex CA images and the simpler random images. There is a strong correlation for ratings of complexity between the two sets, which is encouraging because it suggests that there is a relatively stable relationship between objective and subjective measures even with visually dissimilar types of image. The statistical significance of these correlations has been avoided thus far, but will be taken up in the discussion of results.

Mean (log) Rating	Correlation	Mean (log) Rating
Complexity CA	0.34	Preference CA
Complexity Random	-0.27	Preference Random
Complexity CA	0.80	Complexity Random
Preference CA	-0.26	Preference Random

Table 4 Correlation between subjective ratings.

### Average Responses

Figure 73 shows the averages (mean) across all participants for the four subjective ratings compared to file size. At this relatively crude stage of analysis, we can see that subjective ratings of visual complexity generally correspond with the file size of the images. This is true of complexity ratings for both sets of images, whose results are fairly similar,

whereas preference ratings of the two sets are quite distinct in shape but indicate a weaker correlation.

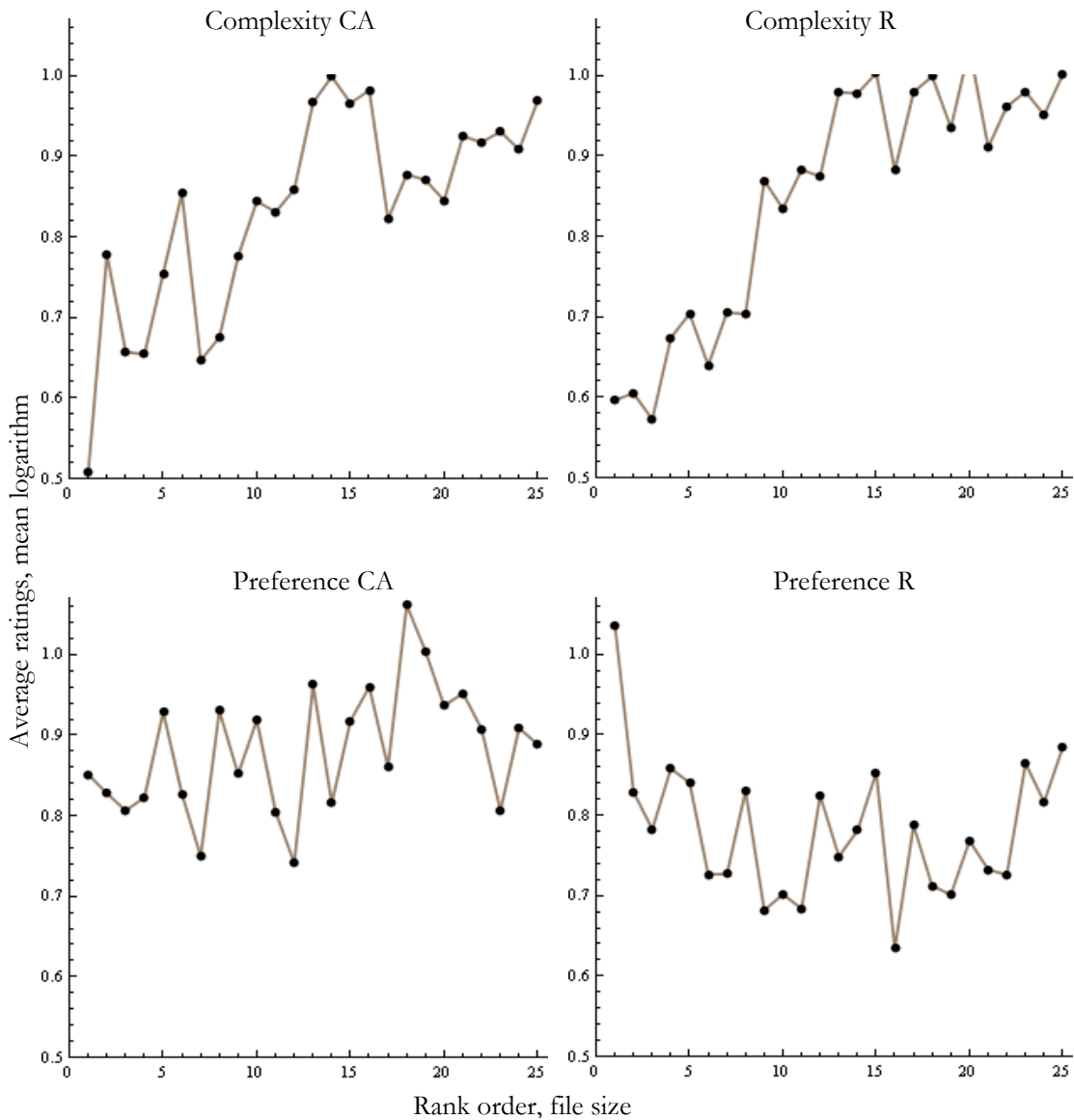

Figure 73 Mean log ratings plotted against rank order PNG file size.

### Influence of Art Training

Table 5 shows how the correlations with file size differ between non-art-trained (MA Construction Management) and art-trained (MA Fine Art) subjects. Ratings of complexity for both image sets do not differ greatly between the two sets of subjects, but their preference does. The non-art-trained subjects show a fairly strong preference for the more complex CA images and the simpler random images. In contrast, the art-trained subjects

have only a slight preference for the more complex of both image sets. Figure 74 illustrates these different ratings, in the same layout as Table 5. The greatest visible difference is that for preference ratings of random images (right-most column), which slopes downwards for the non-art-trained subjects and upwards for the other group.

Group	mean(log) Complexity		mean(log) Preference	
	CA	Random	CA	Random
Construction Management	0.760	0.699	0.567	-0.790
Fine Art	0.439	0.705	0.159	0.328

Table 5 Influence of art training on judgements of complexity and preference.

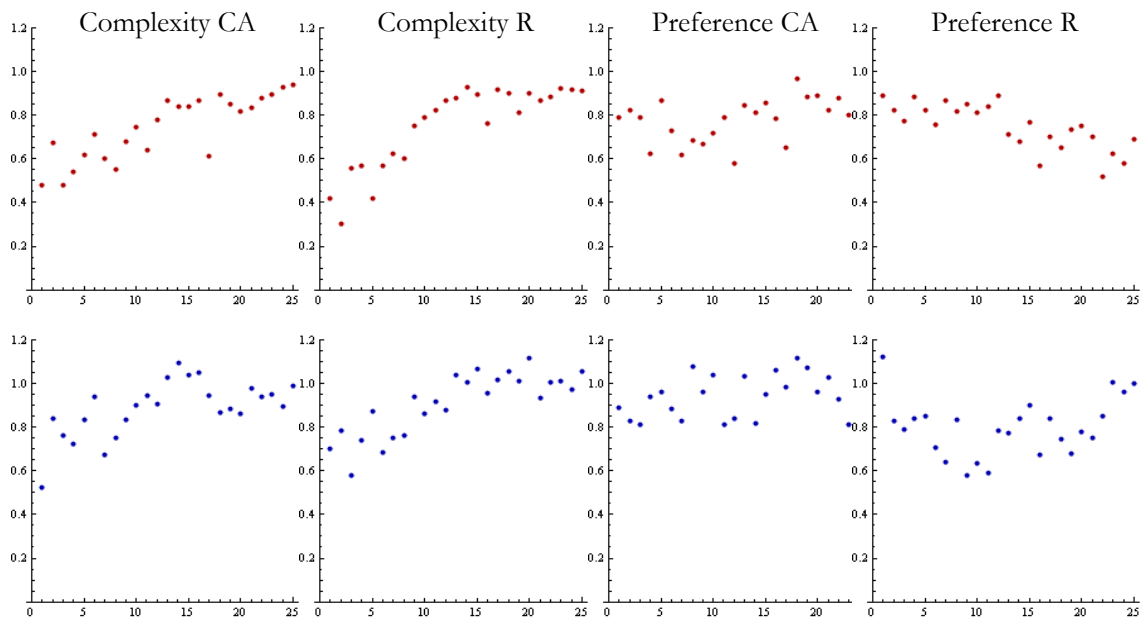

Figure 74 Visualisation of the different responses between participants from Construction Management (top row, red) and Fine Art (bottom, blue). *x*-axis: mean log scores; *y*-axis: rank order file size.

The results show a greater consistency between the groups' ratings of complexity than amongst ratings of preference. The trends revealed by these analyses are comparable to the findings of Locher, Smith and Smith (2001), who reported a similar tendency for art training to affect preference of images more than perception of visual properties such as complexity.

## Inferential Statistics

The following statistical analyses differ from those of the previous section in that they allow us to make inferences from the sample data back to the population at large. These statistical methods can also tell us the degree to which the inferences are valid, that is, the proportion of the correlation that can be accounted for by the particular factors under scrutiny. Regression analysis allows us to find the mathematical relationship between variables, so that we may make predictions of one based on the values of the other. We find the mathematical relationship by attempting to find the line of best fit for the points of data. Figure 75 shows some examples of regression analysis for ratings of complexity of the CA images. Each graph uses a different type of equation as its model, and the regression analysis provides estimates of their parameters, which are plotted as red lines through the data points. The measure of how closely the estimated line fits the data is called the coefficient of determination, or the  $r$  squared value. The  $r^2$  values in these graphs are adjusted to compensate for the number of parameters used. Given a measure of the objective complexity of an image, these functions can be used to estimate its perceived complexity or preference.

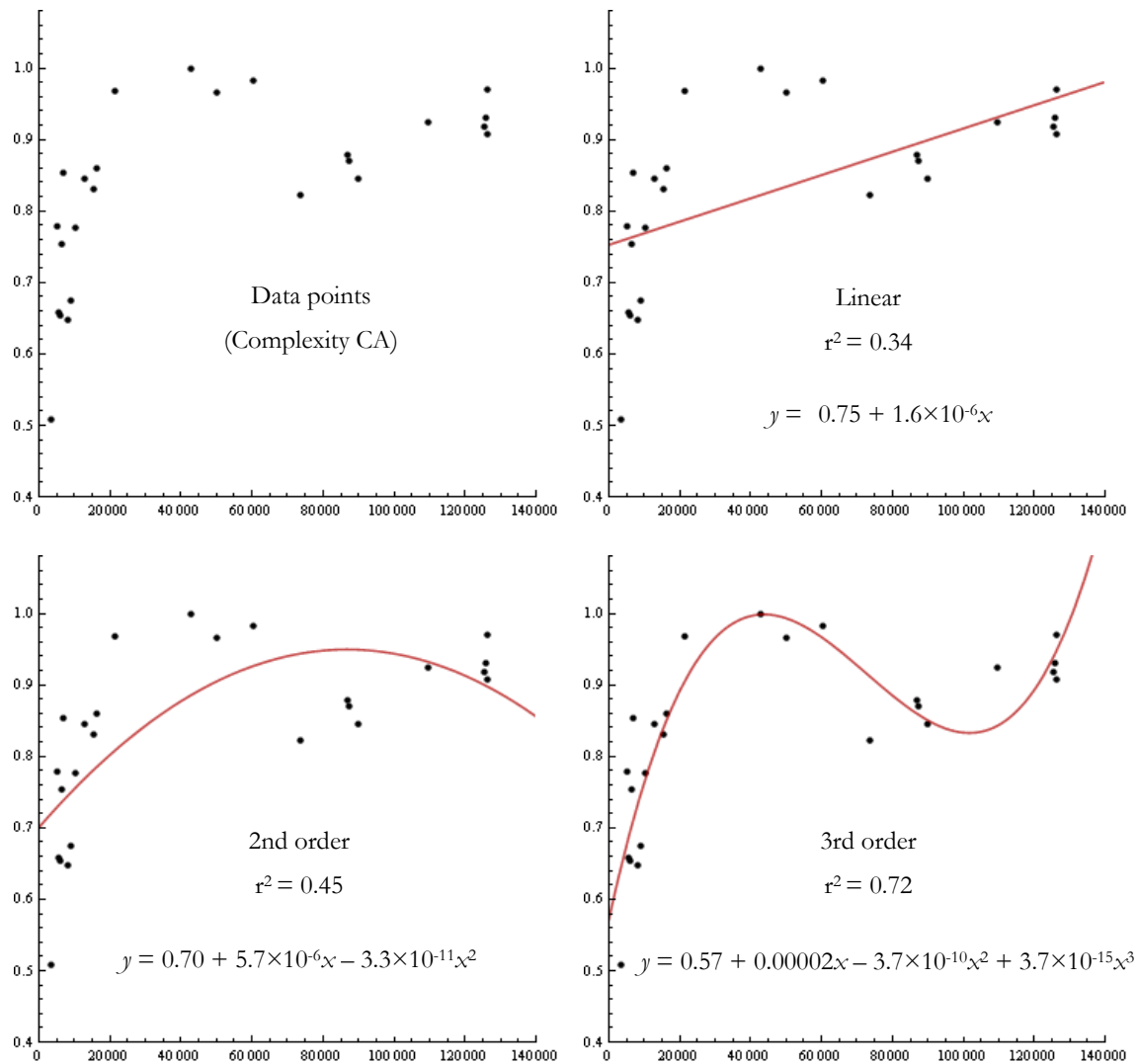

Figure 75 Examples of curve-fitting data by regression analysis, using successively larger-order polynomials. Plots show mean log complexity ratings ( $y$ -axis, no units) against PNG file size ( $x$ -axis, in bytes).

Figure 75 shows the lines of best fit when the data is arranged by absolute file size, but there are alternative ways of arranging this data: It can be sorted into rank order of file size (as in Figure 73) or we can use the logarithm of the file sizes. The latter method is the one adopted by Donderi as a measure of image information content (in line with Shannon's quantitative definition of information), and the lines of best fit for this method are illustrated in Figure 76.

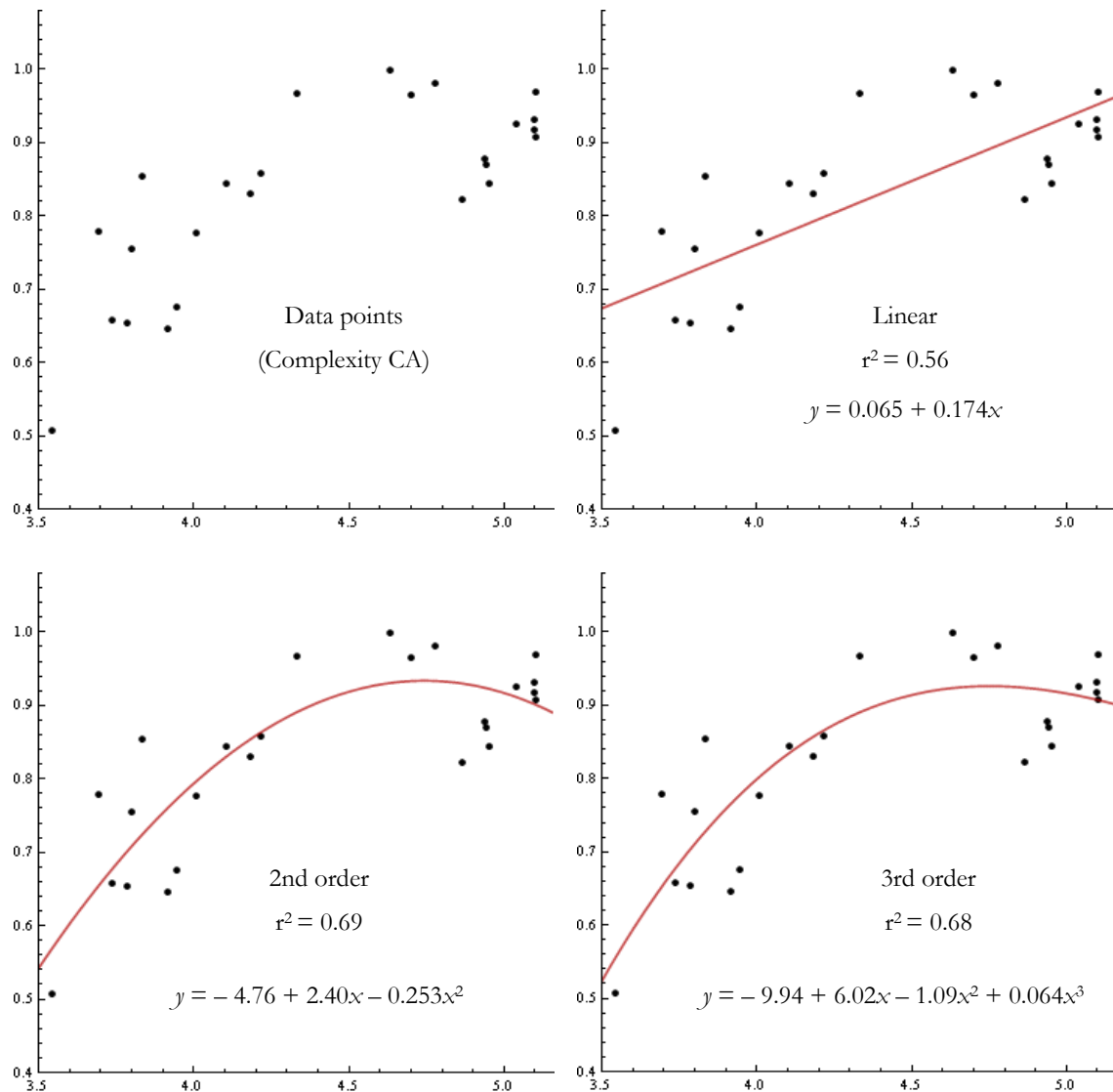

Figure 76 Lines of best fit for mean log complexity ratings ( $y$ -axis, no units) against log PNG file size ( $x$ -axis, in bytes). R squared values are adjusted.

The logarithm transform of file sizes produces more consistent results than the untransformed data. The third-order polynomial used in the regression analysis produces quite different curves for the data depending on whether a transformation is used. The logarithm has the effect of squeezing the points towards the right, which irons out the dip in the line. Figure 77 shows the lines of best fit for each of the four different subjective ratings, and provides a succinct description of the results of this test.



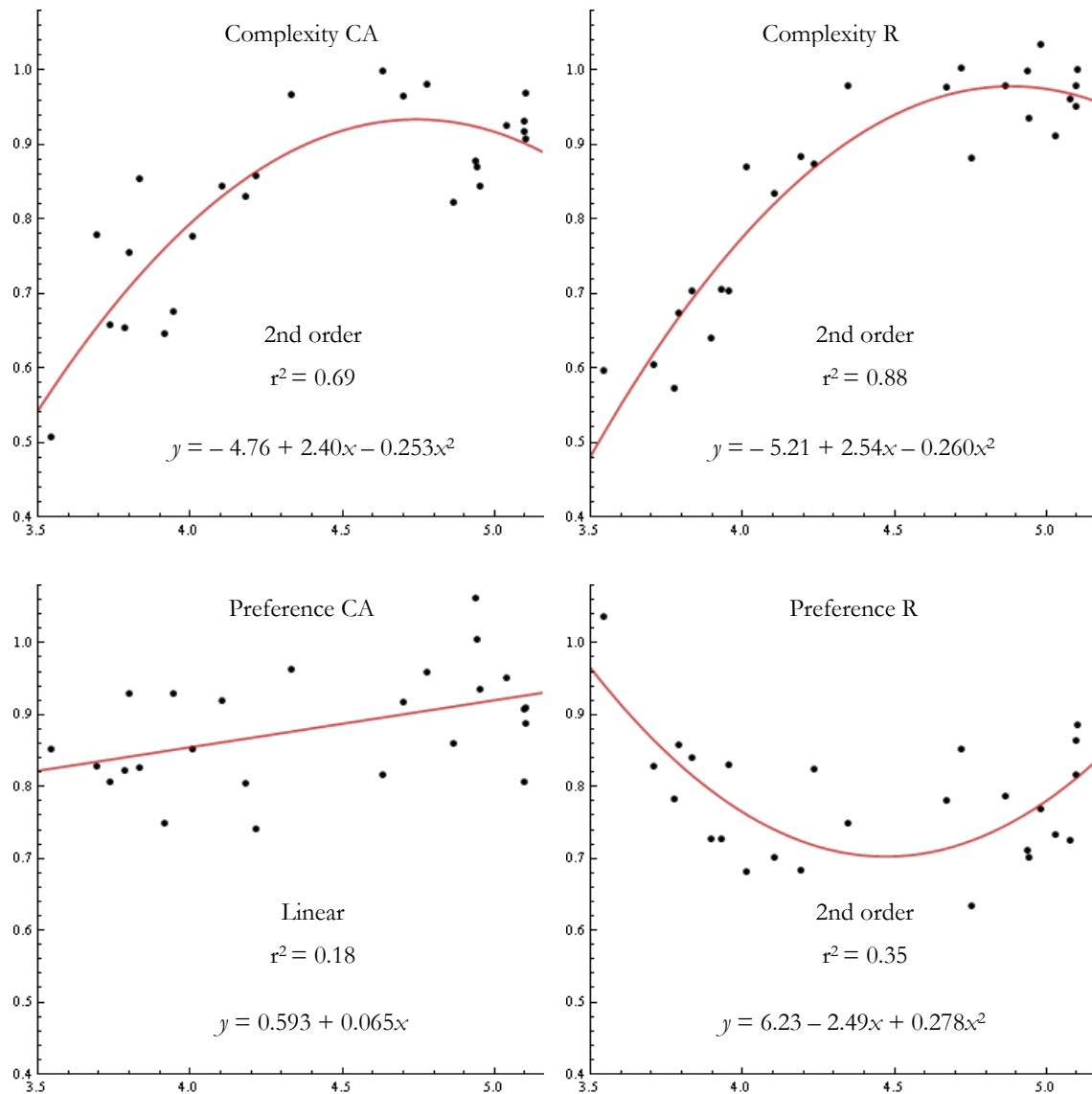

Figure 77 Lines of best fit for the four ratings of test images. Mean log ratings ( $y$ -axis, no units) vs. log file size ( $x$ -axis, in bytes).

### Statistical significance

Correlation coefficients ( $r$  values) are usually given with reference to their statistical significance ( $p$  value), which tells us the probability that the result could have occurred by chance alone. The smaller  $p$  is, the more confident we can be that the results are due to the factors under study. The necessary degree of certainty varies from study to study, depending on their aims and purposes, but in general the more data we can acquire, the more we can be certain of the results. In the present study, we have found a quite strong correlation between objective and subjective measures of visual complexity, but the small

number of participants means that we cannot be very certain about its significance. One way to increase the significance of the results, then, is to repeat the tests with more participants. This is the plan for the next set of tests, which introduce colour to the stimuli.

## Summary

Using the logarithm of both objective and subjective measures of complexity, the lines of best fit are consistent with one expected outcome of this pilot test. It was predicted that Donderi's linear correlation between the two measures of complexity would break down for the most complex images (i.e. that the line would begin to curve downwards on the right), and that this might not be revealed unless a wide range of visual complexity is tested. The results of this test cautiously confirm this hypothesis – there is distinct inverted U shape to the graphs of perceived complexity vs. measured complexity in Figure 77. Perhaps surprisingly, the results are similar for the two different sets of images that vary greatly in appearance. Preference, on the other hand, shows much more variation, which is not surprising given that the workings of aesthetic taste are dependent on many more variables than were accounted for in the present study. Whereas the complexity ratings are similar for both image sets, there is a marked difference in preference between the two. Also, between the two groups of participants there is greater disparity in preference than there is for complexity. A tentative conclusion is that art training does not affect perception of complexity, but it does alter preference for levels of complexity.

The results of Test 1 support this hypothesis: Ratings of perceived complexity form an inverted U shape when correlated with the objective measure of complexity based on information content. However, the graphs of complexity ratings and file size in Figure 77 describe mainly the left portion of this inverted U shape. There are two alternative explanations for this result; either the perception of random images does not function as predicted by Donderi (2006) or the stimulus images are not random enough to see the predicted effect. Given that the stimuli are fairly low-resolution black and white images, which therefore fall short of the perceived complexity of artworks such as Pollock's drip

paintings, the latter alternative is the more likely. The implication for the following test is that the objective complexity of stimuli should be increased and that we should include images that are more random. In other words, we should raise the level of overall complexity in the image set, and widen the spectrum of complexity that it represents. In terms of the fundamental variables of visual complexity identified in Chapter 2, this means that we increase the quantity and the variety of picture elements and widen the scale of order–randomness.

### **Discussion: Visual Resolution**

The results of these tests indicate that the objective and subjective measures of visual complexity correlate linearly only for the least complex images (the upward-sloping left portion of the curve on the complexity graph). Beyond a certain threshold (the peak of the curve), as images become more random they are rated as less complex (the right-hand side of the curve). The stimuli in this study had quite a low printed resolution; individual pixels were clearly visible. It is thought that by increasing the resolution, the most random images will appear even less complex, because as the image resolution approaches the limit of our visual acuity, random images appear ‘smoother’ or more uniform, and would appear to be more simple. Figure 78 illustrates this phenomenon. Each image is composed of random blobs (created using the method in Test 1 described above), but they vary in terms of scale: the images increase in resolution towards the right. What is noticeable is that the images appear smoother with increased resolution. We can imagine the series progressing towards a uniform grey that would appear to be a very simple image, even though we know it is actually composed of a complicated arrangement of different elements.

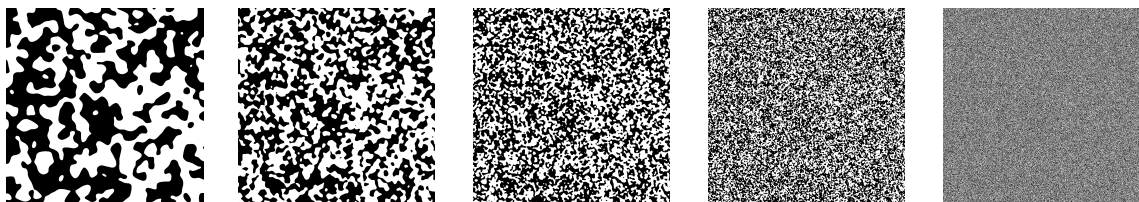

Figure 78 The effect of increasing resolution of random ‘blob’ images.

The point at which the increased resolution appears uniform is dependent on the eyesight of the participant, principally on the property of visual acuity (the ability to resolve detail). Since individual acuity will vary we cannot specify exactly where this threshold lies, but given the common standard measure of 20/20 acuity we can calculate the necessary printed resolution for creating stimuli that approach this threshold. In effect, the relatively low resolution of stimuli in Test 1 limited the approach towards the perception of uniformity. This provides another explanation for the result that only the left portion of the predicted inverted-U-shape correlation is observed. We propose to use a higher resolution in subsequent tests, as this should lead to a more pronounced effect on the correlation between the two measures. The smoothing effect means that the most random images will be rated less complex than the corresponding objective measure as resolution is increased. In theory, then, a random image whose resolution (spatial frequency) is greater than our visual acuity should be indistinguishable from the simplest possible uniform image. We can infer that subjective complexity forms a continuous spectrum whose end-points meet, unlike the objective measure of complexity which exhibits the clearly opposing poles of order (or uniformity) and randomness. In this sense, we could describe the objective scale of visual complexity as linear, and the subjective scale as circular – like a colour wheel. This idea is taken up in the concluding chapter.

## **Test 2: CA and Random Images in Colour**

Test 2 uses random and cellular automata images again, but this time with greater resolution and in colour instead of black and white. In addition to increasing the quantity of picture elements by increasing the resolution of the stimuli, the introduction of colour marks a qualitative difference – it increases the variety of picture elements and raises the overall level of complexity of the image set compared to Test 1. The present test has images that are more random, but the range of patterns is approximately the same as before, representing all four classes of complexity. In this way, we also widen the range of

visual complexity present in the stimuli. The benefit of this action is threefold: It allows for a corroboration of the initial findings, it further tests the validity of the method to cope with more complex images, and it enables a more detailed examination of the hypothesis concerning the perception of randomness.

## Method

### Materials

To create the image set for this test, another program was written in *Mathematica*. The program generated random images and cellular automata images – not the elementary CA with two colours or ‘states’ that were used before, but CA with four colours. The number of rules in this four-colour CA is vastly larger than the elementary CA, and so it is not possible to generate images for each rule. Instead, the rules are chosen at random by generating a number between zero and the number of possible rules of this CA (approximately  $3 \times 10^{38}$ ). Normally, different CA rules are represented with the same colouring, but for the purpose of this test we want to avoid a bias towards a particular colour palette. Therefore, the program that generated the stimulus images also assigned colours randomly to each image. The nature of the CA patterns means that they have between two and four colours each.

After generating a few hundred images, a set is created by sorting the compressed image files in order of size and then making selections spaced roughly equally across the range. The set selected for this test is illustrated in Figure 79. Two sets of the stimulus images were printed at a size of 20cm square on medium-weight white card. Each image was labelled on the reverse side with a reference number for identifying images in the tests. These labels were assigned randomly, and the same labels applied to both image sets.

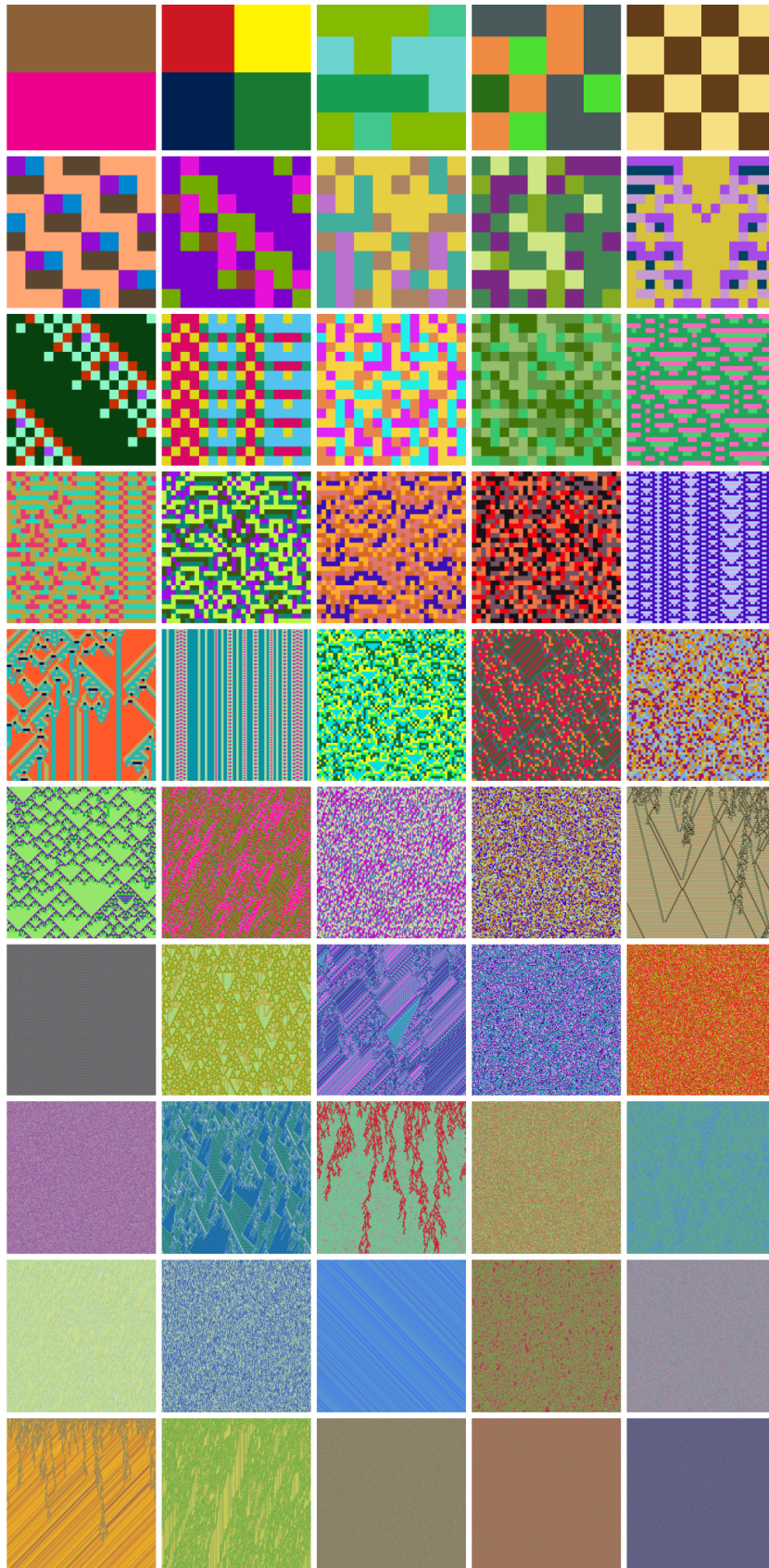

Figure 79 Set of stimulus images in Test 2, arranged in order of increasing file size from top left to bottom right

## **Participants**

Volunteers to participate in the tasks were recruited from postgraduate students in the College of Art & Design and the Built Environment. 20 people took part in the tests, including art-trained and un-trained students.

## **Procedure**

The participants' task is the same as the previous test: Each participant rated a set of images for complexity and preference by writing scores on a sheet. The tasks took place at desks in the postgraduate research office with plenty of room and illumination. The sequence was alternated between successive participants, so half rated complexity first and vice versa. Scores were written in a box labelled with a number corresponding to that on the back of each printed image. The sets of images were shuffled for each participant to obtain a random presentation sequence.

## **Results**

The test results are presented graphically in Figure 80. The top two images show the complete sets of ratings for complexity and preference, visualized with higher scores as hotter colours. The average (geometric mean) ratings are illustrated in the central pair of images, and at the bottom are plotted in graphs against rank order file size. The pattern of colours and the shape of the graphs indicate a degree of correspondence between subjective ratings and image file size, with a stronger correlation for complexity ratings than for preference.

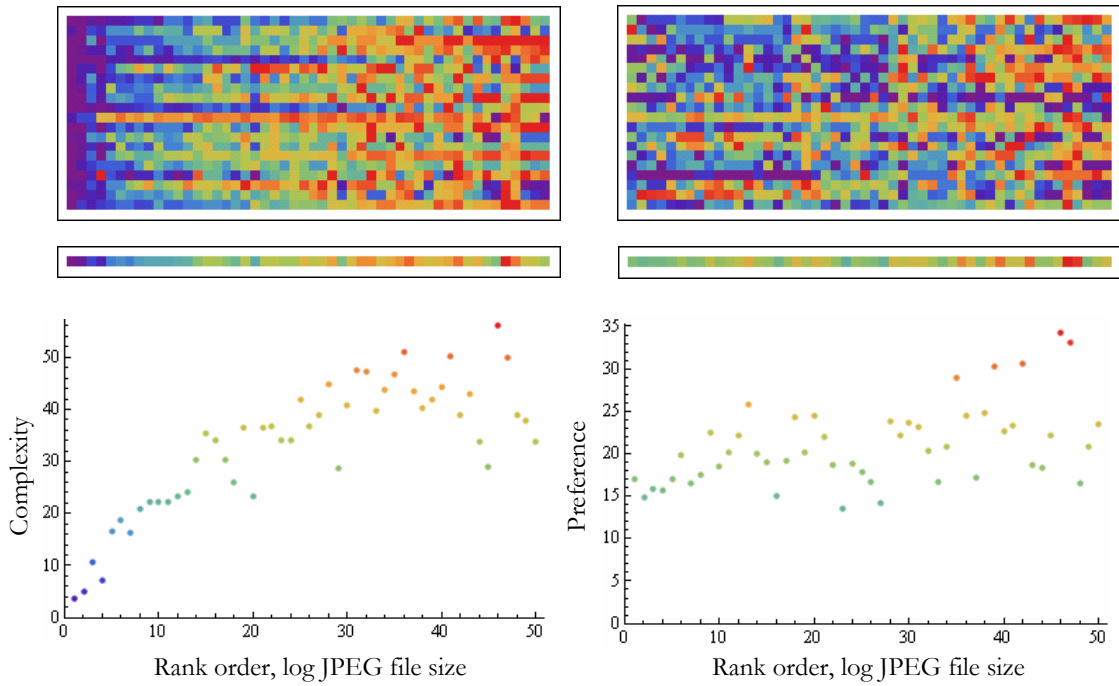

Figure 80 Test 2 results for complexity (left) and preference (right). Top: Complete data – colours represent rating values (blue = low, red = high), participants’ scores are in rows and stimulus images are represented in columns in order of file size. Middle: Geometric mean ratings. Bottom: Plots of geometric mean ratings against rank order JPEG file size (no units).

## Analysis

The statistical analysis reveals a moderate correlation between average (geometric mean) subjective ratings of complexity and preference ( $r = 0.486$ ). The correlation of preference and objective complexity (file size) is slightly weaker, varying with the file type (see Table 6). Similarly, the correlation with complexity ratings varies with file type. TIFF and JPEG file types show a statistically significant correlation with complexity ratings (TIFF:  $r = 0.547$ ; JPEG:  $r = 0.542$ ,  $d.f. = 18$ ,  $p < 0.05$ ) and only JPEG shows a significant correlation with preference ratings ( $r = 0.494$ ,  $d.f. = 18$ ,  $p < 0.05$ ) for this sample size.

$d.f. = 18, p < 0.05$	<b>PNG</b>	<b>TIFF</b>	<b>JPEG</b>
<b>Complexity</b>	0.267	0.547	0.542
<b>Preference</b>	0.279	0.389	0.494

Table 6 Correlations for Test 2.



If, like Besner (2007), we split the set of images into the smallest and the largest files, we find that the correlation with first half of files (smallest files with simpler images) is much stronger ( $r = 0.814$ ) than that with the second half ( $r = -0.078$ ). This shows a dropping-off of the correlation curve for the largest files (most random images). Figure 81 shows the results of regression analysis for complexity and preference ratings with all three file types. As in Test 1, we have evidence of the inverted ‘U’ shape correlation, which is stronger between perceived complexity and file size than for preference.

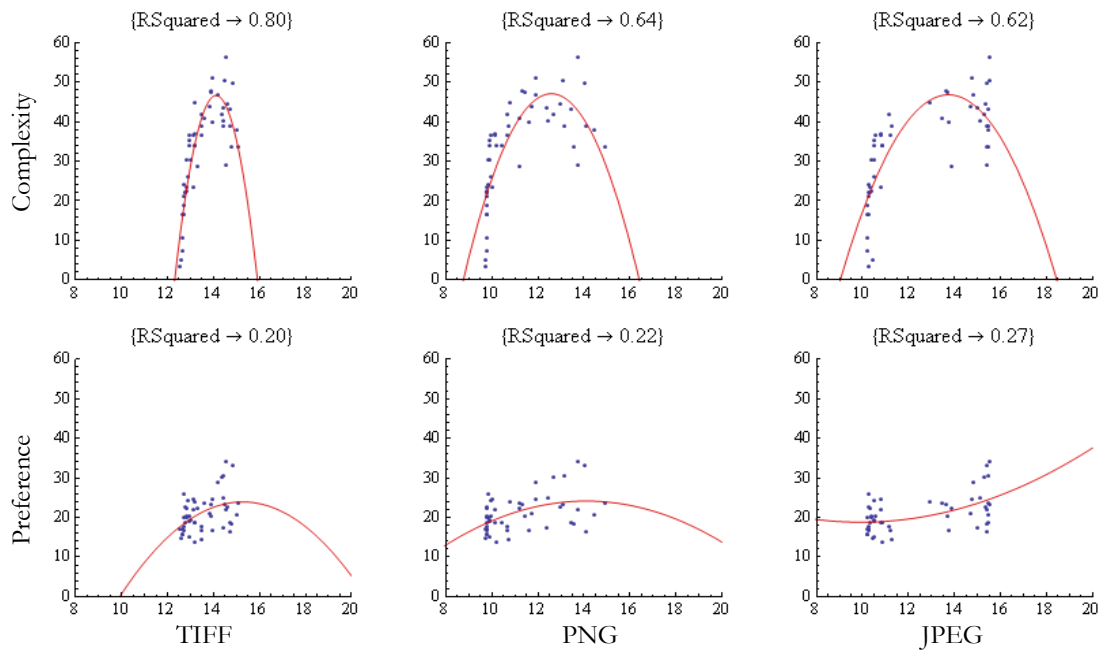

Figure 81 Regression analysis (2nd order polynomial), mean scores (no units) vs. log file size (bytes).

Instead of expressing image file complexity using the logarithm of the file *size*, as Donderi & McFadden (2005), we can use a measure based on file *compression*. The compression ratio of the image files is the ratio of the size of the compressed file to the original uncompressed file, giving a relative value between 0 and 1 (with no units of measurement, because they cancel out). The value of using the compression ratio is that it provides a scale from a maximum of order (maximum compressibility) to a maximum of randomness (minimum compressibility). The results are similar to the other plots, again showing the same shape correlation (Figure 82). The compression ratio scale reveals more

clearly which areas of the informational scale of complexity are represented by the stimuli in this test and which are omitted; clearly, we have few representative samples of maximum randomness, probably because of the limited number of colours used in the stimuli (a maximum of four). The graphs seem to suggest that the threshold of perceived complexity (the peak of the curve) is quite low – a compression ratio of approximately 0.15 – but it is possible that the images are artificially low on this scale: The limited number of colours restricted the file size of even the most random images, which meant that the range of sizes did not approach the upper limit of the compression ratio.

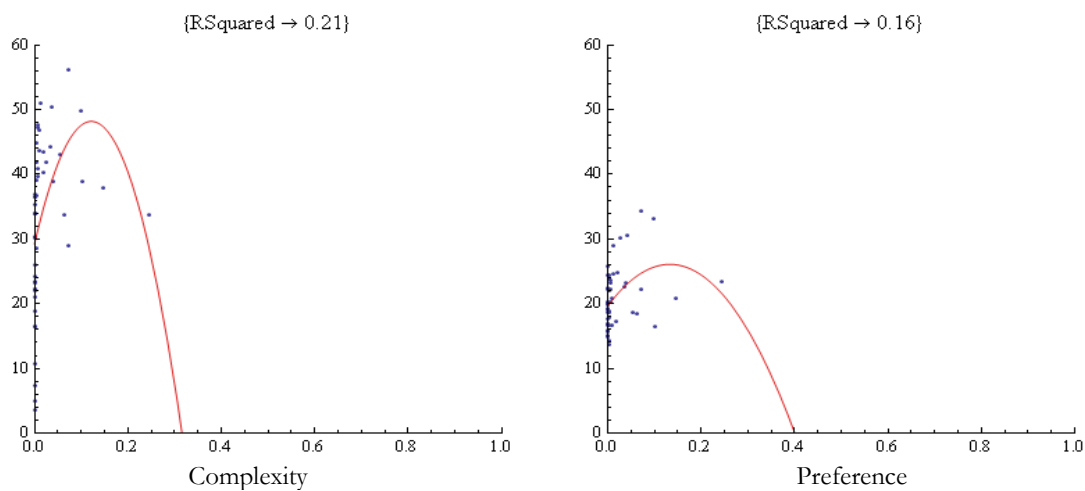

Figure 82 Regression analysis (2 poly) for ratings of complexity and preference ( $y$ -axis, mean scores, no units) against compression ratio of PNG images ( $x$ -axis, no units).

### Effect of Art Experience

Comparing ratings between art-trained and untrained groups of participants, we find no significant difference in complexity ratings, but there is a difference in preference (Figure 83). A between-subject T-test (two-tailed) for art-trained and untrained participants shows no significant difference in complexity ratings between the two groups ( $t = 4.21$ ,  $d.f. = 96$ ,  $p > 0.1$ ). However, there is a significant difference in preference ratings between the groups ( $t = 7.21$ ,  $d.f. = 96$ ,  $p < 0.01$ ), with art-trained participants giving higher scores on average ( $M = 36.07$ ,  $SD = 16.80$ ) than untrained participants ( $M = 31.86$ ,  $SD = 10.82$ ). Despite there being no significant difference in average scores for perceived complexity,

art-trained participants show a stronger correlation between complexity ratings and log PNG file size ( $r = 0.75$ ) than untrained participants ( $r = 0.44$ ).

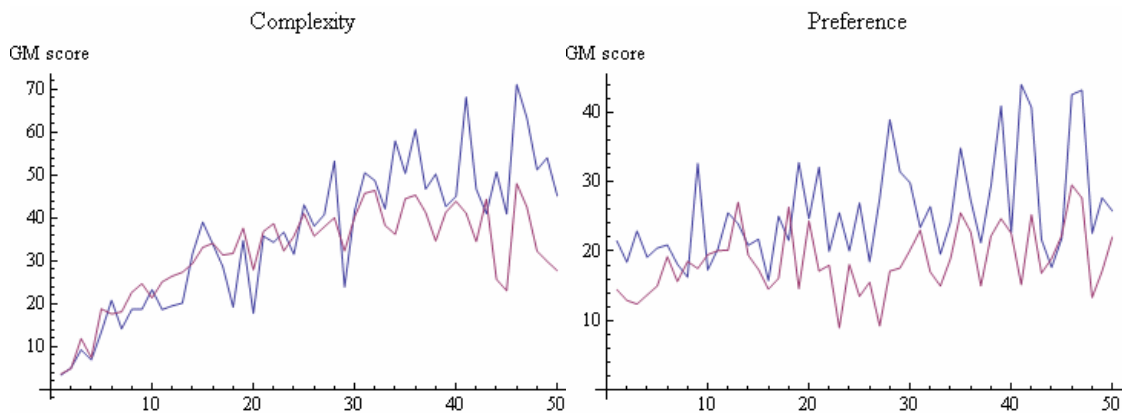

Figure 83 Comparison of geometric mean ratings between art-trained (blue) and untrained (red) participants, against rank order file size (x-axis, no units).

## Discussion

In this study, class 4 CA images are found to be among the highest-rated as subjectively complex. We also find an inverted ‘U’ correlation between objective and subjective complexity. This finding supports Wolfram’s suggestion (2002, p.559) that there is a threshold of visual complexity beyond which we fail to perceive underlying order or pattern. The suggestion is also supported by the result that the class 3 chaotic CA images (which are actually deterministic but which appear random) are rated lower in subjective complexity than the class 4 patterns, even though they are larger in compressed file size. These findings constitute empirical evidence for the hypothetical threshold of perceived complexity, and thus make a contribution to knowledge in the field of empirical aesthetics.

The finding that between the two groups of participants there was only a significant difference in preference suggests that art-training has a greater effect on preferential judgement than on judgements of perceived complexity. If we understand art education and practice to involve the cultivation of aesthetic judgement, we might reasonably expect art-trained people to be more critical, and to rate artworks lower on average than inexperienced viewers. So, why art-training should give rise to higher ratings of preference

overall, and why it does not appear to affect perceptions of visual complexity, is unclear. We may gain more insight into these questions in the following tests, where we repeat the participant grouping for images of art and design. Beside ratings of complexity and preference, a further rating task is added in which participants score the perceived artistic *quality* of the images. It is hoped that introducing this task may clarify the issue by separating judgements of preference – what Kant called a judgement of agreeableness, which is an interested judgement – from judgements of quality, which in Kantian terms is a disinterested aesthetic judgement. This is a common distinction in art; we may have high regard for an artwork in the canon, but we may at the same time dislike its appearance (for example, the work of George Grosz, Philip Guston, and Jake and Dinos Chapman).

In tests 1 and 2, PNG was chosen as the working file type because it produced the smallest files for the type of two-colour image used as stimuli, whereas JPEG files of the same quality were 10 to 200 times larger. Given the fact that JPEG does not generally cope as well as PNG with bi-level (black and white) images (Salomon, 2004), it is perhaps surprising that on average the strongest correlation in Test 1 is given by using ZIP compression on lossless JPEG files. Similarly, JPEG compression performed comparably with the other file types in Test 2. These results are in agreement with Donderi and McFadden (2005) and Besner (2007). It is possible that the reason for the success of JPEG results lies in a combination of near-optimum (ZIP) compression together with operations that are similar to our own visual processing, namely JPEG encoding, which takes advantage of human perception of colour and tone. From these results, we may make the tentative suggestion that JPEG encoding may parallel the low-level visual processing of the retina, while ZIP compression corresponds to cognition taking place in areas of the visual cortex. Obviously, to corroborate this suggestion would require further research beyond the scope of the current investigation.

## Summary

The results indicate that preference is highly variable, and cannot be reduced to a simple function of image complexity. It would appear that preference has something to do with the ‘feel’ of the images in Test 1, because the most preferred tended to be those with smoother edges, suggesting a possible link to tactile preference. In test 2, with a different set of images, it is difficult to see any strong factor that influences preference, but informal interviews with participants suggests that colour preference was amongst the main influences. In the next tests, the motivations behind individual preferences are elaborated with the use of more formal interviews and questions after testing.

Unlike the conclusion of Besner’s (2007) similar investigation into the correlation between objective and subjective measures of visual complexity for fairly complex images, some of the results of this study *do* appear to support Wolfram’s idea of a threshold of visual complexity: The statistical correlations and graphical presentations reveal that subjective ratings peak in the centre of the scale of objective image complexity, and begin to fall as images approach randomness. Even the file-size measure of visual complexity is equivalent to Kolmogorov complexity or AIC, which as we know does not quite follow our intuitive understanding of complexity, it nevertheless offers a convenient and robust method of dealing with the problem of aesthetic measurement. The results of tests 1 and 2 support the proposal to use the file-compression measure of visual complexity with images from art and design.

# Chapter 5

## Visual Complexity and Aesthetic Judgement

### Introduction

The previous tests showed that the chosen methods are feasible to measure visual complexity in general, using ‘artificial’ stimuli. The present test finds out whether these methods work with images of artefacts from art and design. Using real work is problematic because its complexity and variety demands a sophisticated yet robust method of analysis. The method must negotiate the dual constraints of artistic integrity and empirical validity. Is it really possible to measure the complexity of art with this technique? This chapter documents the design, implementation and analysis of the solutions to these problems.

Primarily, this test is concerned with visual complexity at the computational level of description. It is beyond the present scope to explore how the different stages of visual processing contribute to the perception of complexity in biological or psychological terms. Rather, the plan is to measure visual complexity and to see how it corresponds with aesthetic perceptions of artworks. The central question is: Does the file compression measure of complexity correlate with subjective aesthetic judgements of contemporary visual art and design? Aesthetic judgements are measured by asking participants to quantify their perceptions of a variety of images, and a statistical analysis determines how these ratings correlate with each other. Three common image file types and various compression algorithms are evaluated as measures of visual complexity, together with subjective judgements of complexity, preference and quality. In order to determine the criteria that lie behind these aesthetic judgements, we also conduct interviews with participants and perform a qualitative analysis of this data.

## Test 3: Images from Art and Design

The previous tests used synthetic stimuli based on cellular automata and random images, firstly in black and white and later in colour. The black and white image sets have a limited variety of elements (only black or white pixels), whereas the later tests have greater variety with up to four colours in each image. The present test uses samples from a wide range of art and design practices. To allow for a fair reproduction of the artefacts, the digital image files use the RGB colour system, which means that the variety of pixels is vastly greater than the previous tests (the RGB system has around 16 million colours). Together with the increased dimensions of the images in test 3, this increased variety means that the number of possible images in the current setup is much greater than before, and so our stimuli represent a much smaller sample of the spectrum of complexity. As long as we try to sample as wide a range as possible, this should not present a problem.

These tests are designed to progress towards greater complexity of stimuli by gradually increasing the parameters of the variables that contribute to visual complexity. Once again, the technique of magnitude estimation scaling (MES) is used to gather subjective ratings of complexity and preference for images, which are then compared to an objective measure of complexity based on the compression of the image files. Mapping the responses to a wide range of complexity in Tests 1 and 2 provides a useful reference for the present test. In Test 3, the aim is to find out: 1) how different types of visual art on the spectrum of visual complexity; 2) how this complexity relates to aesthetic judgements of preference and quality; and 3) whether those judgements can be related to and predicted by measures based on image file properties. This test has two parts, which use the same stimuli in two different locations, in order to find out whether this has any effect. The first test (3a) takes place in a psychology laboratory, and the second (3b) in an art gallery.

## Hypotheses

Many empirical studies of visual complexity have focused on non-art images. In addition, works of visual art tend to be more complex than the sorts of stimulus images

used in those studies, for example Snodgrass & Vanderwart (1980). These two circumstances guide the design of this test, since they point to gaps in knowledge about the aesthetics of high complexity in general (especially when this complexity approaches randomness) and about the perception of complexity in art in particular. This test aims to fill these gaps in knowledge. The hypotheses are:

1. Image file compression will correlate with judgements of complexity.
2. Familiarity with art and design will correspond with lower ratings of complexity.
3. The test environment will not affect aesthetic judgements.

Besides these central questions, this test also aims to evaluate measurements of visual complexity in art: Will the method that worked for Donderi's radar charts and the cellular automata patterns in the previous tests still be effective for images of contemporary art and design? We also evaluate the comparative performance of data compression algorithms in three common image file types (and compression algorithms) as follows: TIFF (lossless LZW), PNG (lossless Deflate) and JPEG (lossy JPEG). One feature of the test is that once the subjective data has been collected it is possible to carry out retrospective analysis on the image files. We also have the opportunity to apply image transformations, such as edge-detection algorithms, and to see how this affects file compression and its correlation with subjective data.

## **Test 3a: Psychology Laboratory**

### **Method**

#### **Materials**

To gather visual material besides my own artwork, invitations were sent to artists and designers which asked if they would lend a piece of work for use in these tests. Fifteen people responded positively to the invitations, with a few respondents providing more than one piece of work. Because this test uses as stimuli artefacts from art and design, we will



have to use scanned digital images for the objective measure, but for the subjective ratings we could use either reproductions or the originals. Experiments by Locher, Smith & Smith (2001) reported little difference for ratings of complexity across different formats of reproduction, and almost no effect of art training either: Locher *et al* called this effect ‘facsimile accommodation’, and it suggests that perception of collative aesthetic properties such as complexity is less affected by the format and location of an artwork than we might have thought. These findings support the decision to use digital reproductions of artworks for both the objective and subjective measures in the next tests. Using the same digital files as the basis of the objective and subjective tests also makes for a fairer comparison between the two measures (as opposed to using the original artefacts for subjective ratings and digital reproductions for objective complexity measure).

There are a few important criteria for the representation of this material as stimuli: Firstly, they must represent a wide range of contemporary work, so that the test results are relevant to today’s visual practices. This was fulfilled by using painting, drawing, woven and printed textiles, photography, and digital prints loaned from contemporary practitioners, including university students and staff, professionals, and two children. There are equal proportions of images in landscape and portrait (horizontal and vertical) alignment. Secondly, the images must show the artefacts without cropping or re-sizing. This requirement imposes a constraint on the size of work that may be used, which is determined by the size of the scanner – in this case, A2 paper size (420 × 594 mm). Thirdly, the resolution of the images is an important factor, because it affects the measure of complexity and because it also influences the quality of the visual array perceived. 300ppi is used for scanning, and 150dpi for printing, since the average human visual acuity is also around 150dpi (20:20 vision means the ability to resolve two points separated by one minute of arc, which is approximately equal to perceiving one dot at 150dpi when viewed at the closest focusable range of about 6 inches).

## Stimuli

The stimulus images in this test comprise fifty colour images of art and design work, scanned at 300dpi and printed life-size on A2 paper. The decision to use printed images, rather than displaying the original works, was made in order to allow for a fair comparison with the file-size measure of image complexity. Given that one aim of the test is to correlate objective (file-compression) and subjective (MES) measures of complexity, it is important that the two measures are based on the same thing – in this case, digital image files are the basis of both the file-size measure and the printed stimuli. For some pieces such as the resin-based paintings, this could have been a particular difficulty since their appearance changed dramatically with the lighting conditions. The decision to use prints as opposed to original artefacts is also supported by Marr's account of the principal physical factors in the visual perception of an image: Marr names geometry, reflectance, illumination and viewpoint as factors that determine the intensity values of an image (1982, p.41). Using prints effectively limits the potential variation in reflectance that would be caused by the variations in viewpoint and illumination that naturally occur in the context of viewing. Admittedly, this variation cannot be eliminated entirely, but it is constrained to an acceptable level – primarily by using prints, and secondarily by printing onto paper with a semi-gloss finish. The minimisation of variation in reflectance levels is confirmed by viewing the prints from different angles and in different locations relative to the sources of illumination.

There was a problem with scanner used (which was the only one of that size available), which introduced a colour cast and produced scan lines caused by variations in the scanning heads. To correct this problem, I created a 'blank' scan of the white scanner lid to produce an image of the imperfections only, and then 'subtracted' it from each image by processing in *Photoshop*. This seemed to solve the problem – the printed colours looked more like the artefacts and it removed the scan lines.

Most of the artefacts have a specific orientation – they have a ‘right way up’, but some, such as the textiles, do not. Of the stimulus images with a particular orientation, there is an approximately equal number of horizontal and vertical. The remaining images were laid out so that the total numbers of ‘landscape’ and ‘portrait’ orientations were equal.

The scans and prints have fixed dimensions, but the size of the art and design objects varies – some of them fill the area and some do not. The images that do not are printed with white borders. If we are to measure the image’s objective complexity by file size, then we face a decision about whether or not to take account of these borders, and this depends on which type of complexity measure is chosen. On the one hand, because the borders are composed only of uniformly coloured pixels, these areas are highly compressible, which means that they would be expected to add little to the overall file size and so might be safely disregarded for the absolute file size measure. But on the other hand, if we are to use the compression ratio instead of the absolute file size, then these borders may affect the result. This problem and its solutions are discussed in the presentation of results.

### **Participants**

Thirty-one people participated in these tests, 19 male and 12 female. Staff and students from the schools of Art & Design and from Psychology at NTU were recruited by email or by personal invitation, and some personal friends also volunteered to take part. Of the 31 participants, 6 were people who had contributed artwork for the tests. From a scientific point of view, this situation may appear to be a potential confounding variable. It is justified in this case with the argument that it reflects the everyday processes of art and design: art practitioners commonly evaluate our own work against that of others.

### **Setting**

The setting for Test 3a was a laboratory used for teaching psychology. It contained ten large hexagonal tables, which provided plenty of room to lay out five prints on each table, and enough space for participants to walk around and view the images. There was a

computer on which data was entered, and a desk and seating for administrative work. Interviews with participants were held at this desk in the room.

Because many of the stimulus images are printed with white borders, the tables' darker surface made the borders an intrusive visible feature of the stimuli. The problem is that this noticeable white border added to the visual array present in the stimuli. To get around the problem we could have cut out the images of the artefacts, but it would have resulted in stimuli of different sizes, reducing their consistency and making the analysis more difficult. The solution was to cover the tables in white paper to provide a background of the same colour as the borders, which made them almost unnoticeable.

### **Variables and Units of Measurement**

Of the many variables in this test, some need to be controlled whilst others are recorded. The principal dependent variable under measurement is visual complexity, and since this property can be affected by more primitive attributes such as image size and resolution, these need to be made consistent. Here is a summary of the test variables:

**Dependent:** Objective: complexity (measured by image file compression, as file size and compression ratio). Subjective: complexity, preference and quality (measured by MES).

**Independent:** Image file type/compression algorithm (TIFF/LZW, PNG/DEFLATE, JPEG/JPEG); test environment (psychology lab, art gallery); art experience (trained, untrained).

**Controlled:** Digital image dimensions (7016x4961 pixels) and scan resolution (300 ppi); colour model (24-bit sRGB); image print size (594 × 420 mm) and print resolution (150 dpi).

The file size measure of complexity is expressed in bytes, but compression ratio has no units because they cancel out. The subjective MES data are similarly dimensionless

because there are no standard units for magnitude estimation of aesthetic properties (unless we convert the data to  $z$ -scores, which are units of standard deviation from the mean).

## Procedure

Participants were given written and verbal instructions before conducting the test. Each person was informed that their task was to rate the images for the various aesthetic properties by quantifying their perceptions (MES). Usually with magnitude estimation scaling, a standard is provided and a score assigned as a reference. In this test, participants were instructed that the minimum score of zero corresponds to a complete lack of perceived complexity, preference or quality, such that for the complexity measure a score of zero would apply to a blank image (i.e. the simplest possible image). Participants recorded their ratings for the images by writing numbers on score sheets. Explicit definition of the properties was not given, only clarification of the sense in which the word was meant. For example, the most frequent request was for clarification of 'quality'; it was explained that it meant how good work of art it was perceived to be (i.e. quality of the artwork, not the print quality). Participants were free to choose a rating scale, and were allowed as much time as needed to evaluate each image. Including interviews with participants after the task, the procedure took from half an hour to an hour per person.

## Results

A graphical representation of the average ratings of complexity, preference and quality is presented in Figure 84, in which the images are arranged in order of geometric mean scores. With this arrangement, it is difficult to see any patterns in the data, but it allows us to identify particular artworks. In regard to my creative experiments with images approaching the threshold of visual complexity, the majority of these images in this test are amongst the highest rated for perceived complexity. As a comparison to these subjective ratings, the same images are arranged in order of JPEG file size in Figure 85.

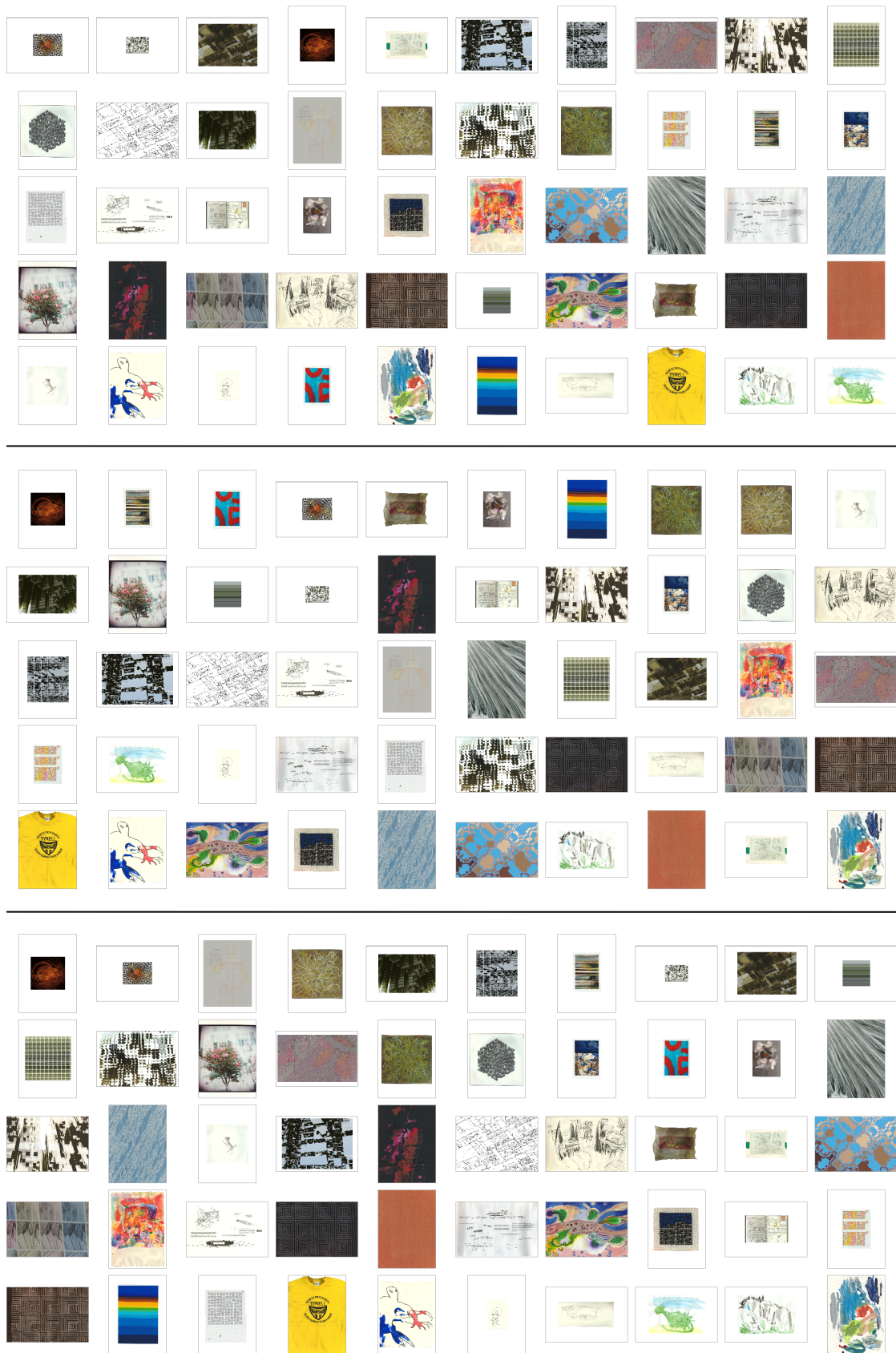

Figure 84 Test 3A: Images arranged by average ratings of complexity (top), preference (middle) and quality (bottom).

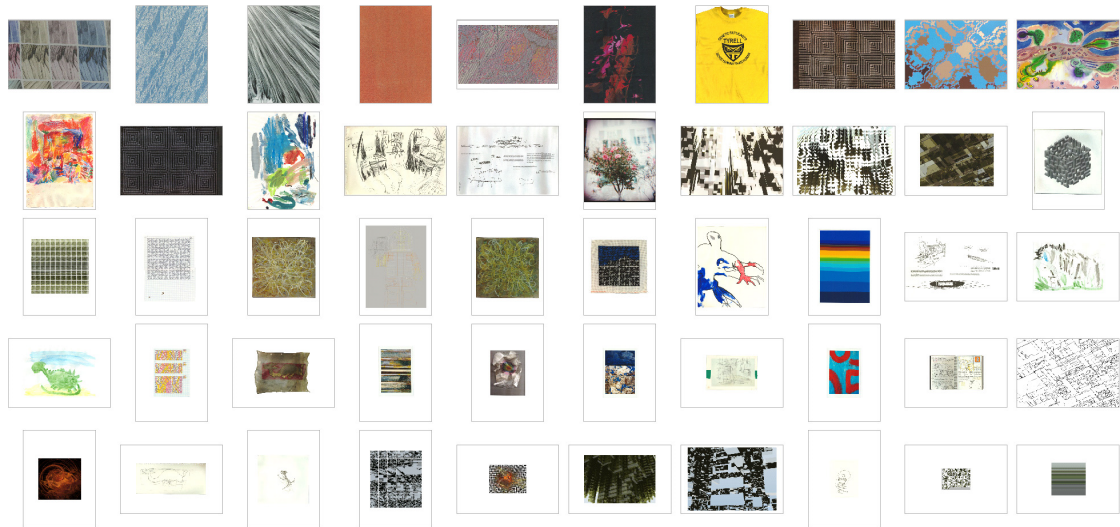

Figure 85. Images arranged in order of JPEG file size (from largest at top left to smallest at bottom right).

From this arrangement, it is apparent that the smallest files are those with the largest areas of homogeneous colour, and also that these tend to be the ones with large white borders. The image in Figure 86 is the fourth-smallest compressed file because of its large areas of flat colours – mainly blue and black. The image three places to its left in Figure 85 is made of multiple smaller versions of the same picture, and even though this one has a larger white border, its greater detail makes it a bigger file. It would be useful to find an objective measure of image complexity that ignored the white border in the same way that the subjective ratings appear to do. A possible solution is to use a measure which is not based on the entire image but only on the non-border areas, and for this we need to use the compression ratio of the file. This method is examined further in the discussion section that follows these results.

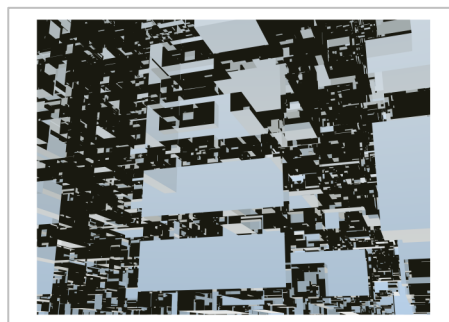

Figure 86. *P32b inv grey cell green gappy close5 big c* (2007), digital print.

Table 7 shows the result of Pearsons' product-moment correlation for pairs of the three subjective ratings, using geometric mean scores. There is a stronger correlation with image quality ratings than that between ratings of complexity and preference. In other words, the results suggest that visual complexity is more closely related to how good an artwork is perceived to be than to how much it is liked as an image.

	<b>Complexity</b>		
	0.54		0.81
<b>Preference</b>		0.81	
			<b>Quality</b>

Table 7 Correlations between subjective ratings (geometric mean scores).

Correlations between subjective ratings and file compression are compiled in Table 8.

Subjective ratings (geometric mean)	Log file size			Compression ratio (virtual)		
	TIFF	PNG	JPEG	TIFF	PNG	JPEG
<b>Complexity</b>	-0.27	-0.25	-0.19	-0.15	-0.18	0.03
<b>Preference</b>	-0.33	-0.31	-0.42	-0.15	-0.15	-0.15
<b>Quality</b>	-0.32	-0.33	-0.23	-0.05	-0.07	0.07

Table 8 Correlations between subjective ratings and objective measures of complexity.

The results show almost no relation, with a tendency for a negative correlation. This means that the effectiveness of the file-size technique as a measure of visual complexity does not work for the images in Test 3a. An explanation for the poor result compared to that in test 1 and 2 might be that the wide variety of artefacts represented in the stimulus images confounded judgements of complexity. In other words, there were many other factors at work in the style, size, colour and composition of the stimuli which may have influenced the reported aesthetic judgements. This interpretation would be in line with Birkhoff's restriction of his aesthetic measure to similar objects and images. Given that there are significant correlations between the subjective ratings (Table 7), however, it is



reasonable to assume that the variety of images also causes difficulties for the file-compression measure, and therefore that the main reason for the poor correlation between objective and subjective measures lies with the performance of the file-compression measure on these images.

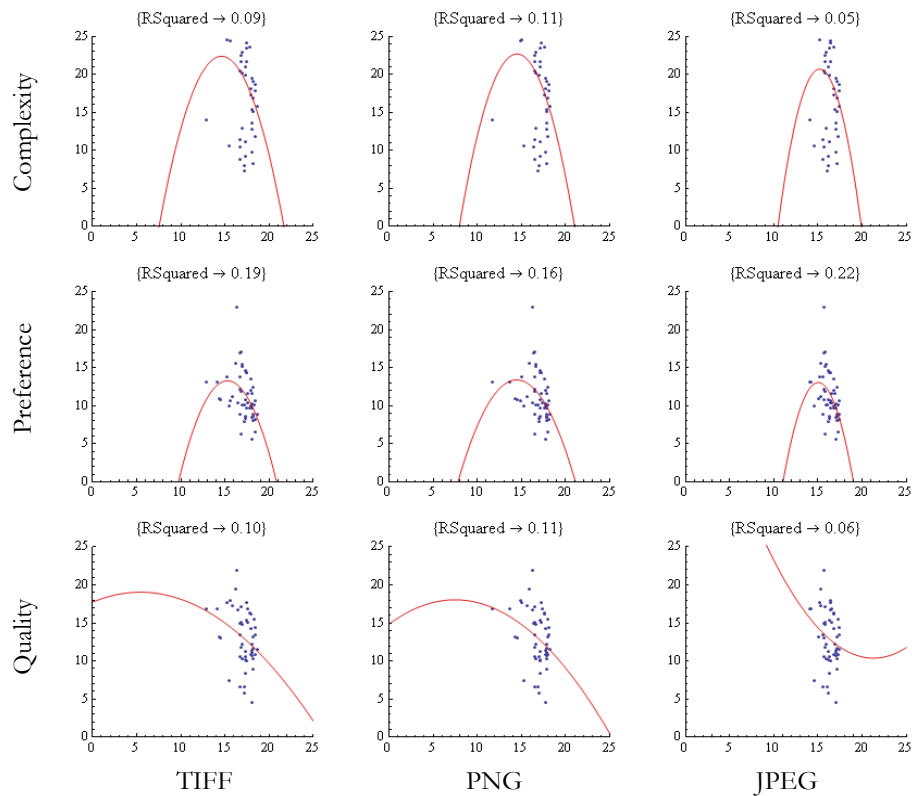

Figure 87 Test 3a: plots of log file size ( $x$ -axis, bytes) vs. subjective scores ( $y$ -axis), with regression analysis (2nd order polynomial).

## Discussion

### Compression Ratio

Instead of using the absolute file size, another way of measuring the data compression of image files (and therefore the complexity of the images) is to use the compression ratio. This is a measure calculated by dividing the size of the compressed file by the size of the uncompressed file. It is more informative because it indicates not only the *size* of an image file but also how much it has *changed* through compression. There are two conventions of writing compression ratios: One is such that for a compressed file

which is a quarter of its original size, we would write '4:1' or '4'. The alternative is to write '0.25', and this is the convention adopted here, since it is the direct result of the calculation.

One way of deriving the compression ratio of an image is to make two versions of the file – one compressed and the other uncompressed – and to read their actual file sizes. A problem with this is that the size of the files may vary with different computers and also that lossy file types, such as JPEG, cannot be saved *without* compression. A more reliable figure can be obtained by calculating the amount of memory (RAM) required to display the image on a computer. The size in memory is very close to the uncompressed size, and it is more consistent because it depends only on the image area (number of pixels) and the bit depth (amount of memory allocated per pixel) of the chosen colour system (Salomon, 2004). In this test, all the images share the same number of pixels ( $4961 \times 7016 = 34,806,376$ ) and the same colour system and bit-depth (sRGB, 24 bits or 3 bytes per pixel), and so they all have the same size in memory ( $34,806,376 \times 3 = 104,419,128$  bytes or about a hundred megabytes). Therefore, calculating the compression ratio (file size divided by size in memory) gives us a relative measure rather than an absolute one, which is more informative.

### **The Problem with Borders**

Because all the test images have the same size in memory, the rank order based on compression ratio is no different to that based on the absolute file size, and so this measure of image complexity is still affected by the border areas. To take account of the effect of borders on the compression ratio, we need to use a value for the size in memory which is based only on the number of pixels that make up the main image by subtracting the number of border pixels from the total. In practice, this is achieved by image analysis in *Photoshop* of files with transparent border areas, since this clearly distinguished the border pixels from the rest of the image (otherwise, white pixels in the image may have been counted as white border pixels). So, for images that have a border, we calculate the compression ratio based on the size of a virtual image which is equal in area to the whole

minus the number of border pixels. Figure 88 illustrates how file size and compression ratio vary with different images. The first image is large, the second is the same size including a border, and the third is the same size as the central image without the border.

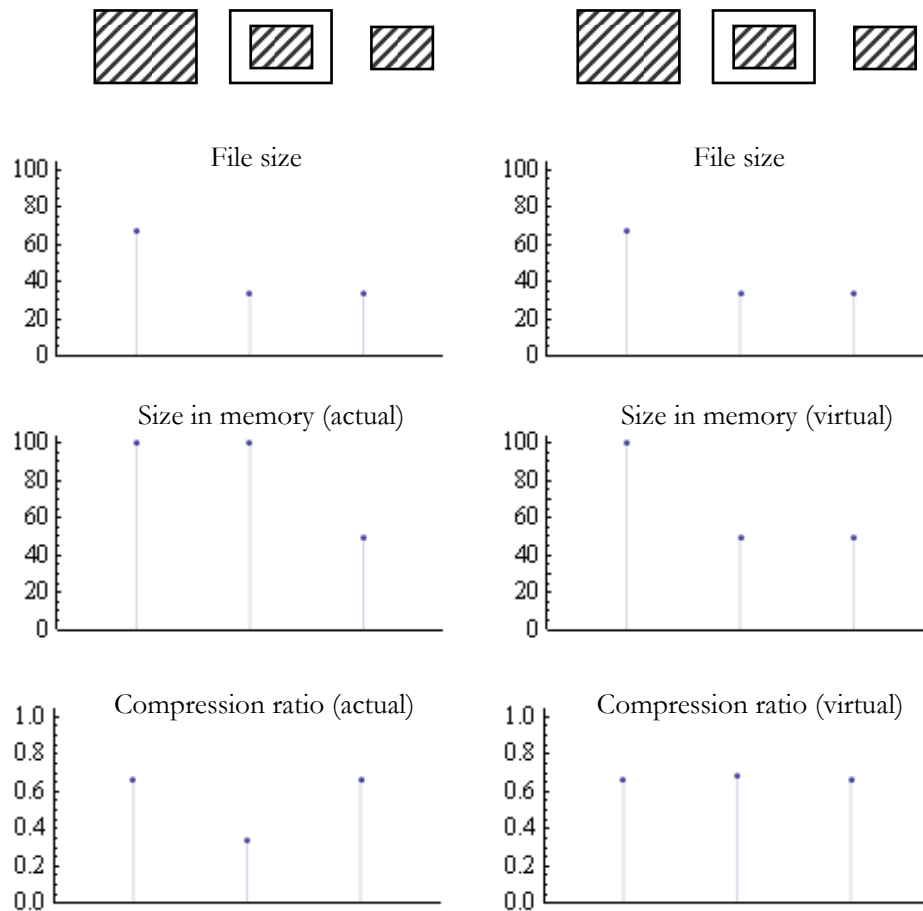

Figure 88 Two types of compression ratio with images of different sizes and borders.

In this hypothetical example (Figure 88) each image contains the same kind of pattern, such that they would be rated subjectively as equally complex. We want the compression ratio measure to do the same. The file sizes are represented in the top graphs, which show that the second and third images have almost equal sizes because the plain border is highly compressible and adds little to the size of the middle image. The second row of graphs shows the size in memory required to display the images. The actual size in memory is proportional to the total image area, whereas the virtual size in memory is proportional only to the non-border area. The compression ratio (bottom row of graphs) is

calculated by dividing the file size (top row) by the size in memory (middle). We can see that the compression ratios in the bottom-right graph are almost equal, which reflects the compressibility of the pattern that all the images share, without being unduly influenced by the dimensions of the images or the presence of borders. This method, which I will call the *virtual compression ratio*, is the proposed solution to the unwanted effect of border areas. When we arrange the set of images in order of virtual compression ratio of JPEG files (Figure 89) it appears not to be biased by the border areas, unlike the absolute file size measure (Figure 85).

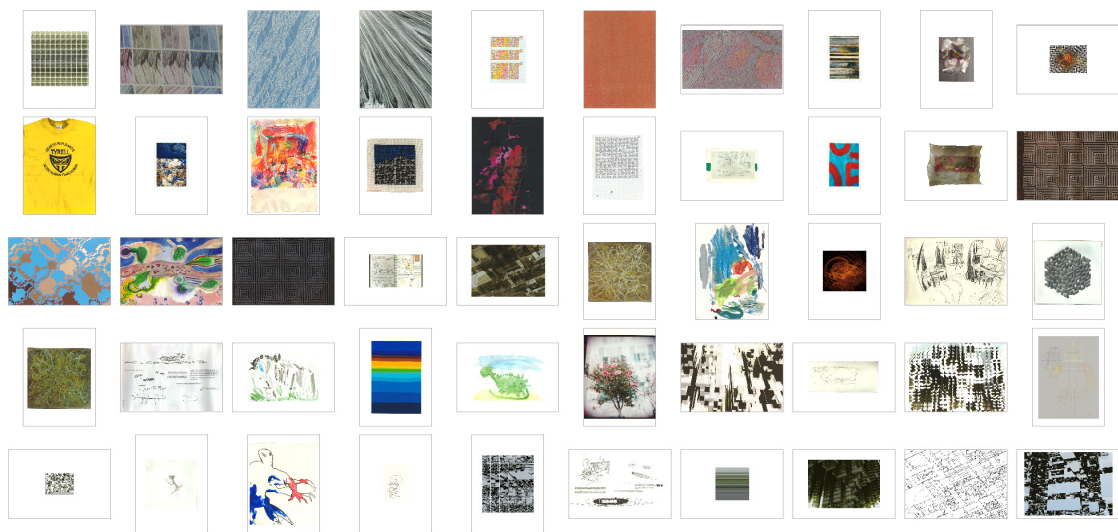

Figure 89 Images from test 3 arranged by JPEG virtual compression ratio (compressed file size relative to size in memory of image area minus border pixels).

The blue and black image (Figure 86) now has the highest virtual compression ratio – it is the one rated simplest by this measure of visual complexity, probably because it mainly comprises large areas of a few flat colours. In contrast, the same image was subjectively rated 8th most complex on average, perhaps because it suggests more complex shapes than it is composed of, since it depicts a complicated three-dimensional structure in simple tonal form. However well the correlation with the subjective measure turns out, we have now found a way of taking account of the unwanted influence of the border areas on the objective measure of image complexity.

In summary, the compression ratio is useful as a measure of visual complexity because it tells us how random an image file is, and also because it allows for comparison of images with different dimensions. It is affected by the presence of borders, however, but by using the virtual size in memory to calculate compression ratio we neutralise this unwanted effect by basing the measure on the significant (non-border) area of the image. Since the printed stimuli depict the artefacts at actual size, this makes the measure relative to the actual size of the original artefact, which may also bring this computational measure closer to perceived aesthetic properties.

## Interviews with Participants

After the rating task described in the previous section, we interviewed the participants of Test 3a. The purpose of these interviews is to see whether we can establish which criteria are employed in the perception of visual complexity and the judgement of preference and quality. The aim is to see whether we can identify the aesthetic properties that constitute the perception of visual complexity, and to see what we can find out from these results, in order to support the quantitative measurement of objective aesthetic properties and their subjective perceptions. A qualitative analysis in the form of transcription coding is employed in order to identify and categorise the responses, and a basic quantitative analysis establishes their frequency and significance. In performing an analysis of qualitative data – in this case, interview transcripts – we are dealing with data based on semantic information, which contrasts with the quantitative analysis of data based on aesthetic information that forms the principal research methods in this project. This qualitative analysis thus provides an opportunity to support the results of the quantitative analysis: We may be able to find out which aesthetic properties have an effect on the perception of visual complexity. We may also establish the criteria behind judgements of preference and quality, and whether there any relationships between these criteria. The following sections document the process of interview, transcription, coding, and analysis.

## Interview Procedure

In all but one case, interviews were conducted in the test location directly after the participants had completed the rating tasks. These were one-to-one interviews with the researcher, although on occasion other test participants who were engaged in the task were present in the same room. Interviews were recorded as audio files, with written notes taken at the same time, and were later transcribed. The 31 participants comprised staff and students from two departments within the University – psychology and art & design. Some of these were people that I know well, but most were volunteers who I had not met before.

A semi-structured approach is adopted, in which a series of seven questions were put to the participants, with opportunity for the conversations to diverge from this structure and to allow lines of questioning to develop. Interviews began by giving the participants an opportunity to ask questions and by asking how comfortable they were with the task. The main focus of the questions was to identify the criteria employed in the rating task by establishing how the participants had made these judgements. Questions generally took the form “What made one image appear more complex (or more preferred, or higher quality) than another?”, and follow-up questions were frequently employed to elaborate participants’ responses. After responses to these questions had been gathered, participants were asked about their involvement with art and design and to what extent they were trained in this discipline, the purpose of which was to define the grouping for analysis into art-trained and untrained participants. Finally, participants were given an opportunity to add further comments. In summary, the structure of the interview is as follows (Table 9):

1	Do you have any questions about the tests?
2	Were you comfortable with the procedure?
3	What were the criteria you used to rate complexity?
4	What factors influenced your most and least preferred images?
5	What criteria did you use to judge quality?
6	Would you say that art and design is part of your day-to-day life?
7	Is there anything else you would like to comment on?

Table 9 Interview structure.

## Transcription

Before we can begin the analysis, the recorded interviews need to be transcribed. This was performed by the researcher, since I had also conducted the interviews and taken notes. A total of around 6 ½ hours of recording were transcribed to approximately 50,000 words, it taking on average five or six times the length of each interview to transcribe into text. Participant identities are anonymised, and we refer to individuals by their number (P1, P2, etc.). When, on occasion, a word or phrase could not be identified, this was marked in the transcription with the symbol '[?]', sometimes with the addition of a comment explaining whether it was inaudibly quiet, or with an alternative interpretation for a word if there was some ambiguity. Where possible, participants were contacted to clarify such issues with interpreting the recordings and the transcripts. Punctuation of these transcriptions was a matter with some degree of freedom in its interpretation, but an attempt was made to apply consistency to the texts, for example, using commas (,) for brief pauses and ellipses (...) for longer ones. The interviews were transcribed into a tabular format, with each alternate contribution from participant and interviewer being placed in a separate box within the table. The timings of these responses were labelled in a column every so often throughout the transcribed text, in order to facilitate finding a portion of a text in an audio file and to provide a record of the interview process. An example of these transcribed texts can be found in Appendix C.

## Coding

After the transcription process, we may begin the qualitative analysis. In this project, we adapt methods detailed by Saldana (2009) – *The Coding Manual for Qualitative Researchers*, which provides a down-to-earth account of qualitative coding methods with an emphasis on their practical application. Saldana describes textual coding as an exploratory and iterative process, recommending that the coding goes through first-cycle and then second-cycle coding stages. These methods analyse the transcriptions by identifying and enumerating answers to the interview questions, enabling a basic statistical analysis to establish the frequency and the significance of these responses.

## Structural Coding

The first-cycle coding method applied in this project is what Saldana categorises as an “elemental method” called *structural coding*, which is applicable to studies with “multiple participants, standardised or semi-structured data gathering protocols, hypothesis testing or exploratory investigations to gather topics lists or indexes of major categories or themes” (2009, p.66). Structural coding is therefore a suitable method for the interview transcripts in this project. We employ this method in order to identify the major themes of the participants’ responses as led by the questions in the semi-structured interview. It works by applying “a content-based or conceptual phrase representing a topic of enquiry to a segment of data that relates to a specific research question used to frame the interview” (Saldana, 2009, p.66). The structural coding method breaks down each transcript into sections according to these codes by grouping together individual statements. In practice, it was applied by colour-coding sections of the transcribed texts (cf. Table 10 and Table 12). This process forms structural units of analysis for second-cycle coding. The seven structural codes are (Table 10):

1	Questions about the task	Red
2	Comfort with the procedure	Orange
3	Complexity criteria	Yellow
4	Preference criteria	Green
5	Quality criteria	Blue
6	Art training	Purple
7	Comments about the task	Grey

Table 10 List of structural codes and their colour codes.

## Pattern / Focused Coding

The second cycle coding method employed in this project is based on a mix of methods which Saldana (2009) identifies as *pattern coding* and *focused coding*. Pattern coding generates inferential codes that identify emergent themes – it identifies the ‘what’ and the ‘how’ in order to answer the ‘why’ questions. This is appropriate to our study, in which we are looking for the reasons why participants rated images as they did by identifying which



aesthetic properties influenced their judgements. Focused coding searches for the most frequent or significant initial codes to develop salient categories, and it requires decisions about what makes the most analytic sense (Saldana, 2009, p.155).

The second-cycle coding process begins by generating a tentative list of codes focused on answers to the interview questions. The structural codes provide a means of identifying the relevant portions of the transcribed texts. For each topic (i.e. each of the seven structural codes), a set of initial codes is generated by listing each answer and grouping these into pattern codes. Pattern codes are refined by iterating the method through a cycle of generating, pruning, grouping, splitting and sorting. The list of codes for complexity criteria (i.e. for structural code 3) is reproduced in Table 11, and the full list of codes can be found in Appendix D.

01. Quantity of picture elements
02. Variety of picture elements
  - a. Number of varieties
  - b. Amount of variation
03. Level of detail (*“amount of detail”, “busy-ness”, “intricacy”*)
04. Number of colours
05. Amount of colour (*“vibrancy”*)
06. Amount of time
  - a. In making the work
  - b. Looking at / understanding the work
07. Redundancy (*“if the detail’s repeated, it’s sort of less complex”, “[randomness] would make it, er, more visually complex but less informationally complex”, “if you’ve got too many colours they’ll almost become like one colour, then... then it negates it”*)
08. Amount of work or difficulty
  - a. in making
  - b. in perceiving (*“cognitive load”, “how much time or how much effort it takes to unpick what’s actually going on within the image so that you can understand the image... It’s like a difficulty to reading the images.”*)
09. Amount of information
  - a. Aesthetic (visual)
  - b. Semantic
10. Depth (*“Three-dimensionality”, “layers”*)
11. Ambiguity
12. Size
13. Flaws

Table 11 List of codes for complexity criteria, with examples of responses coded.

Some of the codes in Table 11 have explanatory examples of the types of response that are encoded. These are the codes that group together different responses, or in which there is some variation in the phrases used. Those codes without explanatory examples did not have these issues, generally being stated in an unambiguous form using words similar to the descriptive codes themselves. Where codes have parts *a* and *b* (codes 02, 06, 08 and 09 in Table 11), these allow for various levels of response. For example, one interviewee mentioned “amount of information” as a criterion for rating complexity, and this is coded as ‘09’. If an interviewee makes a more specific statement, such as “amount of visual information” then this would be coded as ‘09a’. By grouping or splitting these multiple-part codes, we can make the analysis more specific or more detailed as required.

Once a stable set of codes has been established by iterating the code-generating process, the next stage is to apply these codes to the texts, so that we may identify the presence and frequency of interviewee responses. It is important to note that although the pattern codes are generated from each of the individual structural codes, the answers to which the codes refer may be found in parts of the text other than its own topic, and so the whole of each text must be carefully scanned in order to identify responses and apply codes for each of the topics. A topic section may contain more than a single code, depending on its content. An example from a coded transcription is shown in Table 12.

The codes applied to the transcripts are constructed from the name and number of the pattern code, for example ‘Complexity01’ or ‘Quality07’, rather than using a more descriptive code such as ‘level of detail’. The reason for using this format is that it allows for a computer-based quantitative analysis by counting the occurrences of these unique numeric codes, which are less problematic to process than descriptive codes because they are composed of single ‘words’ as opposed to strings of text. Unfortunately, this format also makes it difficult to read the coded transcripts and identify the meaning of the codes without referring to the complete list (included in Appendix D), but since a quantitative analysis is our goal, we retain this format.

00:00	GB	Have you got any questions for me?	Questions01
	P2	No.	
	GB	That's easy. Were you comfortable with the procedure?	Comfort01
00:28	P2	Yeah, fairly straightforward.	
	GB	Good. Right, can I ask what were the criteria you used to rate complexity of the images, you know, what made one image more complex than another?	Complexity03
00:36	P2	I think just the level of detail in the image.	
	GB	OK	
	P2	Some just have a lot more detail in them than others and some are very simplistic.	
	GB	Mm-hm. Not the size?	
00:48	P2	No, not the size at all, no.	
	GB	OK, um... What factors influenced your most or least preferred images?	Preference02
00:56	P2	Umm...	
	GB	What made you like something?	
1:02	P2	I don't know. I think it's just kind of instinctive really	
	GB	OK	
1:06	P2	I like art but I think I know very much what I like and what I don't like. And quite often it's, um, quite dichotomous. I either very much like it or don't	

Table 12 A portion of a transcribed and coded text.

## Results

After collecting the list of codes from the right-most columns of the coded transcriptions such as Table 12, we are able to perform a statistical analysis. First the data has to be cleaned by removing duplicates in each participant's data, because we want to avoid counting the same answer more than once per person. The reason for this is that we are trying to find out *how many participants* gave each response, and not *how many times* each participant gave a particular response. After data cleaning we perform a count of the pattern codes within each structural code and rank them accordingly. The following sections include selected results of this statistical analysis and qualitative overviews of the coding for each of the interview topics (the complete tables of these results can be found in Appendix E). Where applicable, we group the codes and perform another statistical count as a second stage of analysis. Following these analyses, we see what patterns we can find in the distribution and type of responses by categorising and classifying the grouped codes.

## **Questions about the Task**

Half of the participants (18 out of 31) stated that they had no questions at the beginning of the interview. The most popular questions were about the purpose of the tests (5 participants) and how many of the images were my artworks (4 participants). Some said that until this task, they had not considered visual complexity as an aesthetic property of artworks, but that they found the idea quite interesting, and that it either made them re-appraise artwork they had already seen, or would make them think about visual complexity the next time they encountered art. Several people wanted to know what my findings were, and a few were particularly interested in seeing their own results. Confidentiality was maintained with this data, in accordance with the ethical guidelines of the University, but I obliged a few of the participants with graphical representations of their individual results (unfortunately, the poor statistical correlation of this data meant that the graphs were not very appealing). More than once I was asked ‘What is the most complex artwork you have seen?’ I found it hard to answer, so I turned the question around. The most common answer was Jackson Pollock’s drip paintings.

## **Comfort with the Procedure**

24 of the 31 participants said that they were comfortable with the task. Surprisingly, given their experience with test procedures and rating scales, it was the psychology-trained individuals who found the rating procedure more difficult than the art-trained individuals. A possible interpretation, which was suggested by a few interviewees, is that the psychologist’s familiarity with percentage and Likert scales of rating made the less-common MES technique seem more unusual than it did to the artists, who were generally unfamiliar with any such test procedures. Some of the participants revealed that they had used a different rating system to that specified in the instructions (see Appendix A). This meant that whereas the MES method specifies only a lower bound (zero) to rating values, some participants admitted using a scale ‘out of ten’ or a percentage scale. Since these participants said that they had understood that they could have exceeded the limits of these scales (because this had been explained verbally beforehand, being the essential principle of

the MES rating method), the data sets remain valid and are not discarded from the current analysis.

### Complexity Criteria

Table 13 shows the results of rank-order analysis of the criteria for judging visual complexity. It includes a description of each code, its frequency count, percentage (of the total number of responses in that structural code group) and rank order. We can see that the top three criteria are the level of detail, the number of colours and the redundancy of the images. ‘Level of detail’ is the descriptive code for a variety of responses, most of which actually contained the word ‘detail’, but also included in this code were such phrases as “busy-ness” (P7) and “intricacy” (P30). In contrast, ‘number of colours’ is a relatively unambiguous concept that was not expressed in a greatly different kind of wording.

Criteria for judging Complexity (18)	Code	Count	% (73)	Rank
Level of detail	03	10	13.70	1
Number of colours	04	9	12.33	2
Redundancy	07	9	12.33	2
Amount of work or difficulty: In perceiving	08b	7	9.59	4
Depth	10	7	9.59	4
Quantity of picture elements	01	5	6.85	6
Variety of picture elements: Number of varieties	02a	4	5.48	7
Amount of work or difficulty: In making	08a	4	5.48	7
Amount of colour	05	3	4.11	9
Amount of information: Aesthetic (visual)	09a	3	4.11	9
Variety of picture elements: Amount of variation	02b	2	2.74	11
Amount of time: In making the work	06a	2	2.74	11
Amount of time: Looking at / understanding the work	06b	2	2.74	11
Size	12	2	2.74	11
Amount of information	09	1	1.37	15
Amount of information: Semantic	09b	1	1.37	15
Ambiguity	11	1	1.37	15
Flaws	13	1	1.37	15

Table 13 Results of quantitative analysis of complexity codes.

The most frequently counted code for complexity criteria is the level of ‘detail’. If we understand the meaning of this term as relating to the constituent elements of an image, then it refers to the amount of visual elements present and, at the same time, to the size of those elements. Thus, the rendering of an image ‘in greater detail’ but at the same size means that it is composed of a greater number of smaller elements. Conversely, with a greater number of smaller elements at our disposal, we are able to compose an image with more detail. So, we can understand this criterion as relating to one of the fundamental attributes of visual complexity (identified in Chapter 2, pp.151–153) – namely, the *quantity* of picture elements. Greater detail means more elements and greater visual complexity.

The second-most frequent responses identified in the results are the number of colours and the redundancy of the images. In relation to the fundamental attributes of complexity, the criterion ‘number of colours’ corresponds to the *variety* of picture elements. A greater variety of elements contributes to greater complexity in terms of an objective measure because it requires a longer and more complicated description. As in the case of ‘detail’ (quantity of picture elements), this criterion also has a positive correlation with complexity; more perceived colours means more perceived complexity.

In contrast, ‘redundancy’ has a negative correlation with complexity, and it concerns the last of the three fundamental attributes of visual complexity – the *order* of picture elements. The descriptive code ‘redundancy’ is identical with the concept from information theory which has been discussed throughout this thesis and which forms the basis of the file-compression measure. This is the idea that repetitive patterns offer no new information and thus do not contribute much to estimates of complexity further than that of the repeating unit itself. Participants expressed this concept in various ways, such as P7, who initially described their perception of complexity as being proportional to the amount of perceived detail, but who later qualified that statement with the concept of redundancy:

...at first I was thinking just busy-ness, as, you know, how busy it is, how many different things are going on, basically. [...] But then if the detail's repeated, it's sort of less complex somehow.

Similarly, P16 expressed a comparable idea with reference to the number of colours, rather than to the repeating unit of patterns:

...if it's black and white, it would be more simplistic than if it had more colours in it. But then, that said, if you've got too many colours they'll almost become like one colour, then... then it negates it.

This statement also expresses the idea (discussed in Chapter 4, pp.201–202) of the way in which image resolution and its perceived detail relates to complexity. A high-resolution image composed of randomly-coloured pixels may be perceived as a uniform hue if its resolution exceeds the resolving power (visual acuity) of the viewer. The responses of these interview participants confirm that such an effect leads to a reduction in their perception of complexity. In addition, this result offers an explanation for the correlation between perceived complexity and the file-compression measure.

The next-most common responses after the top three, with 7 counts each, are 'depth' and 'amount of work or difficulty in perceiving'. The idea of depth as an aesthetic property of two-dimensional images was expressed in a few different ways by the participants, from the straightforward "it's more to do with depth rather than anything" (P18) to more ambiguous phrases such as "amount of layering" (P26) and "whether it was two-dimensional or three-dimensional" (P29). It is interesting to note that the aesthetic property of 'depth' in a two-dimensional image is restricted to subjective perceptions, and cannot be found in the objective properties of the image (because it has no actual depth). Presumably, the perception of three dimensions forms a more complex percept than that of only two dimensions, because to perceive visually is, in a sense, to re-construct a visible scene in our minds. In Marr's (1982) computational theory of perception, depth perception is built up in stages from a 2D 'primal sketch', based on a two-dimensional array of edges and lines, through a '2 1/2D sketch' to a full '3D model representation', which is based on cues such

as occluding edges, perspective and shading. Thus, the perception of three dimensions involves a building-up of visual elements and is understandably a more complex psychological phenomenon than the perception of two dimensions. This offers an explanation why ‘depth’ should be found amongst the most frequently reported criteria for judging visual complexity. In addition, we can understand the perception of depth and its contribution to the perception of visual complexity in terms of the other criteria that rank alongside ‘depth’, namely the ‘amount of work or difficulty in perceiving’ an image: An image that looks more three-dimensional than another is likely to require more ‘work’ in terms of processing visual elements and constructing a perception.

Most of the complexity criteria identified in these results are aesthetic properties, but some are not: ‘Amount of work or difficulty’ (code 06) and ‘amount of time’ (code 08) are not properties of the aesthetic image itself but factors relating to the production and the perception of an image. Like the perception of depth, the amount of work or difficulty in perceiving an image is a subjective aesthetic property which cannot be measured directly in terms of objective aesthetic properties. These criteria appear to be based on the amount of physical or mental work required in making or perceiving an artwork. Presumably, they are based on the perception of particular aesthetic properties that give rise to the impression of ‘work’ or ‘effort’ on the part of the maker, but without performing another interview to follow up this idea, the current analysis is unable to reveal to what extent this may be true. Nevertheless, the results indicate that these criteria are in fact related to the objective complexity of images in that a greater quantity and variety of picture elements, which make an image more objectively complex, requires greater effort in perceiving and thus contributes to the perception of greater complexity.

If we perform a second analysis based on the next level of code grouping – that is, by counting together the two-part codes (with parts *a* and *b*), the results are as shown in Table 14. Now, the most frequent coded response is the amount of work or difficulty that goes into making and perceiving the work. This result reflects our understanding of measuring



visual complexity in terms of the difficulty in describing or reproducing an image, which underlies the file-compression measure employed in this study. The criteria previously counted as the top three (detail, redundancy and number of colours) are now each shifted one place lower in the rankings below this new grouping.

Criteria for judging Complexity	Code	Count	% (73)	Rank
Amount of work or difficulty (perceiving/making)	08	11	15.07	1
Level of detail	03	10	13.70	2
Redundancy	07	9	12.33	3
Number of colours	04	9	12.33	3
Depth	10	7	9.59	5
Variety of picture elements (number/variation)	02	6	8.22	6
Amount of information (aesthetic/semantic)	09	5	6.85	7
Quantity of picture elements	01	5	6.85	7
Amount of time (making/perceiving)	06	4	5.48	9
Amount of colour	05	3	4.11	10
Size	12	2	2.74	11

Table 14 Second-level analysis of complexity criteria (codes with more than 1 count).

### Preference Criteria

In the coding process, there was often uncertainty about the ‘direction’ of criteria, that is, whether a particular criterion was employed positively, such that it increased preference, or whether it was employed as a negative trait that reduced preference. This issue arose when participants listed criteria without specifying whether it added to or detracted from their preference for an image. For example, preference code 12 may include statements of preference for *and* against computer-generated images. A more detailed interview process than that of the present study could pursue this issue and resolve the ambiguity about negative and positive uses of criteria. In the few cases for which the ‘direction’ of the criteria were actually specified, we are able to include this in the codes, such as preference code 15, which expressed a dislike of pretension. In short, this analysis reveals *which* criteria are employed, but not *how* they were employed. Despite this limitation,

however, the responses generally indicate positive criteria, which do contribute to greater preference.

Another point to be made about the coding process is that in the cases where there is clearly an oppositional pair of criteria, such as ‘abstract’ and ‘figurative’, a two-part code is created. Parts ‘a’ and ‘b’ represent the two opposing criteria, and a descriptive phrase is used to identify both together. For example, codes 05a (‘representational’) and 05b (‘abstract’) could be grouped as ‘level of figuration’. As in the case of the two-part criteria in the list for complexity, those for preference could be counted together in a further analysis (this applies to only two of the preference codes: ‘level of figuration’ and ‘quality of line’). Since these potential groupings bring together opposing preferences, and the validity of this grouping is questionable, we present only the first level of analysis here (Table 15).

<b>Criteria for judging Preference (25)</b>	<b>Code</b>	<b>Count</b>	<b>% (50)</b>	<b>Rank</b>
Instinctive judgement	02	6	12.00	1
Strong colours (bold, saturated)	03	6	12.00	1
Quality of line: Swirly, curved	08b	6	12.00	1
How much time would like to spend looking at it	09	4	8.00	4
Level of figuration: Abstract	05b	3	6.00	5
Level of figuration: Representational	05a	2	4.00	6
Computer-generated	12	2	4.00	6
Complexity	13	2	4.00	6
Pretension (dislike)	15	2	4.00	6
Complementary colours	17	2	4.00	6

Table 15 Top results of quantitative analysis of preference codes (codes with more than one count).

In contrast to the criteria for complexity, these responses are much more varied, and produced the longest list of codes (25 in all). Unlike the complexity criteria, which appear to form natural groupings, the criteria for preference are much less homogeneous and are thus more difficult to make sense of. Some participants said that they liked many of the images very much (for example one participant wanted to buy one of the images) whereas

others were far more critical, admitting to liking only a handful of the images. The variety of responses recorded from interviews is reflected in the poor statistical correlation of the participants' aesthetic judgements. Amongst the top responses we find that preference is an instinctive judgement, which lacks objective criteria, and which we are thus unable to further analyse. The other two top criteria, also with 6 counts each, reveal preferences for strong colours and curvilinear images. The amount of time spent looking at an image came as the fourth most popular criteria, but it is difficult to read much into this because we cannot be sure what motivates this response; saying that we like to spend time looking at an image does not explain *why* we like to look at it. Complexity appears twice amongst the total of 50 counted codes, but we suspect that if the tests had not focused on this property, these responses may not have appeared as frequently.

There is little overlap between the criteria employed for judging complexity and preference. This supports the findings of the quantitative analysis, which indicates that there is little correlation between these two judgements. A possible explanation for this result is that a judgement of preference is not an aesthetic judgement, as defined by Kant, but a judgement of agreeableness (see Chapter 1, p.19). Preference is subjective, as are the aesthetic judgements of the beautiful and the sublime, but unlike those a judgement of preference is not normative (or 'universal', in Kant's terminology). Therefore, judgements of preference are not of the same class as aesthetic judgements proper, which appeal to objective criteria and make a claim to truthfulness that can be argued against.

The contextual review of material in Chapter 2 identified empirical research on the perception of visual complexity, and noted that a number of these focused on preference for images in relation to the judgement of perceived complexity. Evidence for an inverted 'U' correlation between preference and complexity (i.e. a preference for mid-range values of complexity), as proposed by Berlyne (1971), has been supplied by some of this material, whilst others offer evidence to the contrary. Roberts (2007) suggests that the use of different kinds of visual stimuli and different definitions of complexity in such tests are

likely causes for their divergent results, and also that individual differences in personality and cognitive style of participants may have a greater influence upon results than has been assumed. The results of the present study offer little clarification of the issue, other than to support the idea that visual complexity and preference are of two different classes of aesthetic judgement, which provides a hint as to why there may be so much uncertainty and disagreement about their relationship.

### Quality Criteria

There is more agreement amongst the criteria for judging artistic quality than those for preference, and there are fewer codes altogether. Only five of the thirteen criteria have more than one count amongst the total of 40 coded responses (Table 16). The top criterion is the level of skill perceived to have been required in making the work. ‘Skill’ is not an objective aesthetic property; it is a subjective impression which results from the perception of aesthetic properties, but at this stage it is difficult to say which and why.

Criteria for judging Quality (13)	Code	Count	% (40)	Rank
Skill	03	8	20.00	1
Amount of work: In making	01a	6	15.00	2
Suitability for exhibition	05	6	15.00	2
Technical accomplishment (level of finish)	07	6	15.00	2
Difficulty in making the work	04	4	10.00	5
Same as for preference	10	3	7.50	6

Table 16 Top results of quantitative analysis of quality codes (codes with more than one count).

Three participants said that their rating of quality was the same as their preference. We can understand why participants might have a preference for artworks as a result of their perceived quality, but not why some should reverse this relationship and rate as high quality the things that are most preferred. More interestingly, six participants rated quality in terms of the suitability of the artefacts for exhibition. Some of these participants reported that this type of rating consisted of judging whether an image would hang in an

international exhibition, or a local gallery, or on the fridge door at home. This constitutes a different category of response to those criteria based on skill and effort; it is a criterion with reference to the context of the artworld – an *a*-perceptual aesthetic criterion, yet based on aesthetic perception. With the current form of data and the present analytical method, we are unable to say which aesthetic properties might be relevant to this form of judgement, other than to note that, like the criterion ‘skill’, it is a high-level concept which depends on a contextual knowledge of the artworld and its artworks.

Some of the most frequent responses are related to the difficulty of making a work in terms of the level of skill required and the amount of time or effort that it requires. Thus, we could group together the codes 01a (‘amount of work in making’) and 04 (‘difficulty in making’) because of their correspondence in meaning. The result is that ‘amount/difficulty of making the work’ is the second-most frequent of the grouped responses, with 10 counts in total (25%). Similarly, we could group the codes 03 (‘skill’) and 07 (‘technical accomplishment’), because these are similar concepts that differ mainly in being expressed in relation to either the artwork itself or to the maker of the work. This places the group ‘skill/technical accomplishment’ at the top of the frequency counts with a total of 14 (35%).

Criteria for judging Quality	Code	Count	% (40)	Rank
Skill/Technical accomplishment	03/07	14	35.00	1
Amount/Difficulty of making the work	01a/04	10	25.00	2
Suitability for exhibition	05	6	15.00	3
Same as for preference	10	3	7.50	4

Table 17 Second-level analysis of quality criteria (codes with more than 1 count).

### Art Training

There is little to be said about the qualitative analysis of responses to the question of art training and experience, because its purpose is to divide the participants into those with and without art training and experience. This division serves to group the participants in order to perform a quantitative analysis and find out whether this has any effect on the

pattern of aesthetic judgements. Of the 31 participants in Test 3a, 11 are found to have formal art training and are actively engaged in art and design. In comparison, 18 of the 27 participants in Test 3b have art training. This means that in Test 3 overall there are 29 art-trained participants out of a total of 58, which is exactly half. The results of the quantitative analysis of differences between the two groups in Test 3 are presented in the section on pages 261–262.

### Comments about the Task

The top results (those with more than a single count) for the coding of participant comments are shown in Table 18. Almost half the participants had no comments to make. The majority of the remainder said that they found the task to be an interesting experience, and a few of these reported that they had enjoyed it as well. The two other comments in the table are significant criticisms of the task procedure, with two counts each. The first of these concerns the fact that the interviews were conducted in the same room as the rating task, which two participants objected to because they could overhear the conversations, which may have affected the results of their rating. The interviews were held in the same room to allow for the management of both interview and rating task by the researcher, who was working alone, and to allow the participants to complete the required tasks in the shortest possible time. We accept that these conditions were not ideal, and would make provisions for a better system if the tests are repeated.

Comments (12)	Code	Count	% (35)	Rank
No comments	01	16	45.71	1
Interesting experience	02e	5	14.29	2
Enjoyed the experience	02a	3	8.57	3
Shouldn't be using the same room for interviews and task	02c	2	5.71	4
Too many images	02h	2	5.71	4

Table 18 Top results of participant comments (codes with more than one count).

The other significant comment is that there were too many images to rate. 50 images had to be rated 3 times (for complexity, preference and quality), but a consequence of

reducing this number is that it weakens the statistical significance of the quantitative analysis. A more even balance could perhaps be achieved with a slight reduction in the number of stimuli, but since most of the participants were happy with the procedure, we do not consider this issue to be a major concern for the validity of the results. Amongst the remaining comments (detailed in Appendix E), we find a query about whether the artefacts represented in the image set are actually comparable. This is a legitimate concern, and may explain the poor correlation in the quantitative analysis.

## **Analysis: Categorizing the Codes**

In the previous analysis of complexity criteria, we grouped similar codes together and re-counted the codes for these new groups, which offers a broader analytical view of the results. We can go further than this, as suggested by Saldana (2009), by categorizing the codes in order to reveal further patterns in the data. In this stage of analysis, we define a category as a group of criteria, and a class as a group of categories. We do not take this stage very far, nor apply it to all of the coding results, because the analysis undertaken thus far is sufficient to answer the principal research question of identifying the most significant criteria. Therefore, we restrict the categorisation of criteria to focus on the judgements of complexity and quality in order to further explore the relationship between the two.

The majority of criteria for judging complexity are aesthetic properties, the top three including ‘detail’, ‘number of colours’ and ‘redundancy’. In relation to the objective properties of visual complexity identified in Chapter 2 (pp.151–153), we may infer that ‘detail’ in this context can be understood as relating to the *quantity* of picture elements. Similarly, the number of colours can be seen to correspond to the *variety* of picture elements, and the third criterion – redundancy – equates to the *order* of these elements. Thus, in the top three responses to the question of which subjective properties constitute perceived complexity, we find a reflection of the most fundamental objective properties of visual complexity. This finding is further supported by the presence of other criteria that also relate to the properties of quantity, variety and order. Some of these are explicit in the

participants' responses and the descriptive codes (such as 'quantity of picture elements'), whilst others are implied or deduced from the coded responses (Table 19).

Criteria for judging Complexity	Category	Class
Level of detail	Quantity	Aesthetic properties
Quantity of picture elements		
Size		
Amount of information		
Variety of picture elements: Number of varieties	Variety	
Variety of picture elements: Amount of variation		
Number of colours		
Amount of colour		
Redundancy	Order	
Depth		
Amount of time: In making the work	Production	Difficulty
Amount of work or difficulty: In making		
Flaws		
Amount of time: Looking at/understanding the work	Perception	
Amount of work or difficulty: In perceiving		
Ambiguity		

Table 19 Categorisation of criteria for judging complexity.

By identifying the codes with these three principal components of visual complexity, we can see that the remaining criteria are of a different kind. In general, these other criteria relate to practical matters of making and perceiving and artwork, usually in terms of either the difficulty or amount of work involved. This finding also supports our previous discussion on the measurement of complexity (Chapter 2) in terms of the difficulty of description or reproduction. One category of criteria ('production') is based on the practical difficulty of making an artwork. A second category ('perception') relates to perceptual difficulties in making sense of a work. Greater difficulty in production or perception leads to higher ratings in complexity. As a result, we group these two categories into a class which signifies 'difficulty' in both aesthetic production and aesthetic perception.



The same analysis can be performed with the criteria for judging quality (Table 20). The majority of the top criteria can be categorised under the same label as is used for the complexity criteria, namely ‘production’. It makes sense to include this category in the same class as before (‘difficulty’), because the criteria also reflect the difficulty of producing a work: Skill, for example, is a measure of the capacity to perform tasks, and a more difficult task requires greater skill. For the remaining criteria, it makes less sense to classify the categories that have only a single code in each because no grouping can be undertaken (we define a class as a *group* of categories). ‘Suitability for exhibition’ is categorised as relating to contextual knowledge, whilst ‘same as for preference’ is a matter of personal inclination.

Criteria for judging Quality	Category	Class
Skill	Production	Difficulty
Technical accomplishment (level of finish)		
Amount of work: In making		
Difficulty in making the work		
Suitability for exhibition	Context	N/A
Same as for preference	Personal	N/A

Table 20 Categorisation of criteria for judging quality.

From this analysis of complexity and quality results, there are two main findings. Firstly, we find some similarities between their criteria. Whilst the majority of complexity criteria are classified as aesthetic properties, some of the remainder share the same categorisation as quality criteria insofar as they relate to the difficulty of production involved in making a work of art. This finding corroborates our understanding of visual complexity in terms of difficulty in description or reproduction. Perception can be understood as a description or a reproduction of the perceptible world. The perception of complexity depends largely on aesthetic properties that can be categorised in terms of the quantity, variety and order or picture elements. This second finding supports our description of visual complexity’s principal attributes. It also provides a link between objective and subjective aesthetic properties which may explain why we find a correlation between the file-compression measure and the perception of complexity.

## Summary

The analysis of participant transcriptions reveals that the most frequent criteria employed in judgements of visual complexity are related to its principle objective aesthetic properties. Perceptions of the amount of detail, the number of colours, and the redundancy of the images correspond, respectively, to the quantity, variety and order of picture elements. The next-most significant criterion relates to the difficulty in perceiving an image. When grouped with the difficulty of making, it gains significance and is the most frequent criterion.

Judgements based on preference are found to be much more variable and depend to a greater extent on subjective criteria than on aesthetic properties. Some said it was an instinctive judgement made without reference to objective criteria, and equal numbers show a preference for strong colours and for curvilinear images. There is little correspondence between preference criteria and those for the other two judgements.

The criteria for quality are related largely to the amount of skill or the amount of work involved in making, the suitability of a work for exhibition, and the level of technical accomplishment of the work. None of these are purely aesthetic properties; they relate to a contextual knowledge of the work's production and presentation, although they must be derived from such properties as are perceived in an image.

In the later stages of analysis, we find similarities and differences in criteria for complexity and quality. The ranking of individual criteria differ between these two judgements, and whilst the complexity criteria are mainly based on aesthetic properties, those for quality generally correspond to factors involved in the making of a work. Yet both are understood as relating to the *difficulty* of making and/or perceiving an aesthetic artefact, which relates to our objective measurement of complexity based on image file compression. We may infer that the properties that constitute the *perception* of visual complexity also contribute to the perception of difficulty in the *production* of an artefact. The aesthetic properties that are considered relevant to the perception of complexity are

interpreted as skill and effort when it comes to judging quality. A greater degree of those properties of complexity leads to a perception of greater skill or effort on the part of the maker. In other words, the things that contribute to the perception of skill or effort in the making of an image make it more difficult to perceive, and are thus also the things that make an image look complex. The findings of this qualitative analysis support the evidence of a link between visual complexity and aesthetic quality which is found in the correlation of the quantitative analysis.

## **Test 3b: Art Gallery**

The aim of this study is to replicate the previous test in an alternative environment. The present test measures aesthetic judgements of the same art and design images, but in the context of an art gallery instead of a psychology lab. The advantage of this experiment design is that it allows us to see what effect there is upon aesthetic judgements between the two environments – one more controlled and the other more traditional. Notwithstanding these differences, the repeat test also allows for a pooling of results. The test compares objective measures of image complexity with subjective perceptions of complexity, preference and quality, to find out how these aesthetic judgements correspond to each other, and how they vary with art training and in different environments.

### **Method**

#### **Participants**

University staff helped to recruit participants for the tests by inviting their students to take part. Unfortunately, there was a high drop-out rate amongst those who responded, meaning that only 27 people out of a target figure of 30 actually participated in the tests. There were 16 female and 11 male participants, and the proportion of art/design-trained to non-art-trained individuals was also 16 to 11. Eight of the participants had also taken part in the previous test. This was originally thought to present a problem, but actually it allows

for an enquiry into the perceived effect of the different settings by those who have experienced both tests.

## Setting

To conduct the test, it was necessary to find a gallery that could display the 50 printed images. Since it is located in the centre of town as part of the university campus, the 1851 Gallery was chosen as a suitable site (Figure 90). Being part of the university's Waverley building, the gallery is frequently used by staff and students as an informal teaching and working space, but this did not significantly affect the tests and in fact it allowed for the participation of passers-by. The exhibition space was booked a few months before the test took place, and a small social event was scheduled for the opening. The gallery room has a high ceiling and plenty of natural illumination from five large windows.



Figure 90 Composite view of Test 3b setting in the 1851 Gallery.

The gallery walls are painted a neutral cream colour in the places where the work was to hang. The colour of the background to the stimulus images is a significant concern, because many of them have a white border. Whatever is chosen as a background will form part of the visual array presented to the test participants, and therefore it has the potential to affect aesthetic judgements. In the previous test, a white background was prepared by covering the tables on which the images were displayed in white paper. Neither re-painting the gallery white nor re-colouring the image borders to match the gallery walls were practicable options, however (the latter option being incompatible with the requirement of using the same stimuli as the previous test). As a result, this is one potential confounding

factor that may have to be accounted for in the analysis of results, although in practice it appeared to have little effect according to the participants who were interviewed.

## **Procedure**

For this test, the procedure was the same as before, except for the layout of the score sheets, which were re-designed to reflect the arrangement of the images in the gallery by depicting thumbnail images of the stimuli in the same layout. This design meant that participants no longer had to write each score by a numerical index, making the rating task slightly simpler than the previous test, and also allowing for easier comparisons between images and their scores. On average, it took around half an hour to complete the task.

## **Results**

### **Ranked Average Scores**

To illustrate the ranked averages, thumbnail images of the test stimuli arranged by geometric mean score are shown in Figure 91 for each of the three ratings – complexity, preference and quality. These figures tell us that photographs seem to have been rated medium in complexity but fairly high in preference and quality. Almost ironically, the image rated highest for artistic quality was a photocopy of a crumpled coloured-pencil scribble, which doesn't sound very impressive on paper, but which is actually a piece by the experienced artist Jonathan Willett. Textiles are generally rated in the bottom half of the ranks, except for two silk prints that came 15th and 18th for preference. Two woven flooring fabrics were rated lower for preference, and two cellular automata pattern furnishing fabrics came out lowest. The images at the bottom of all three rating categories are the two paintings done by my 3 year old twin nephews, of a zebra and a dinosaur. They are noticeably higher in preference ratings; a few participants commented that they were charming pictures, whilst one or two participants thought that they were imitations of children's drawings done by more competent artists.

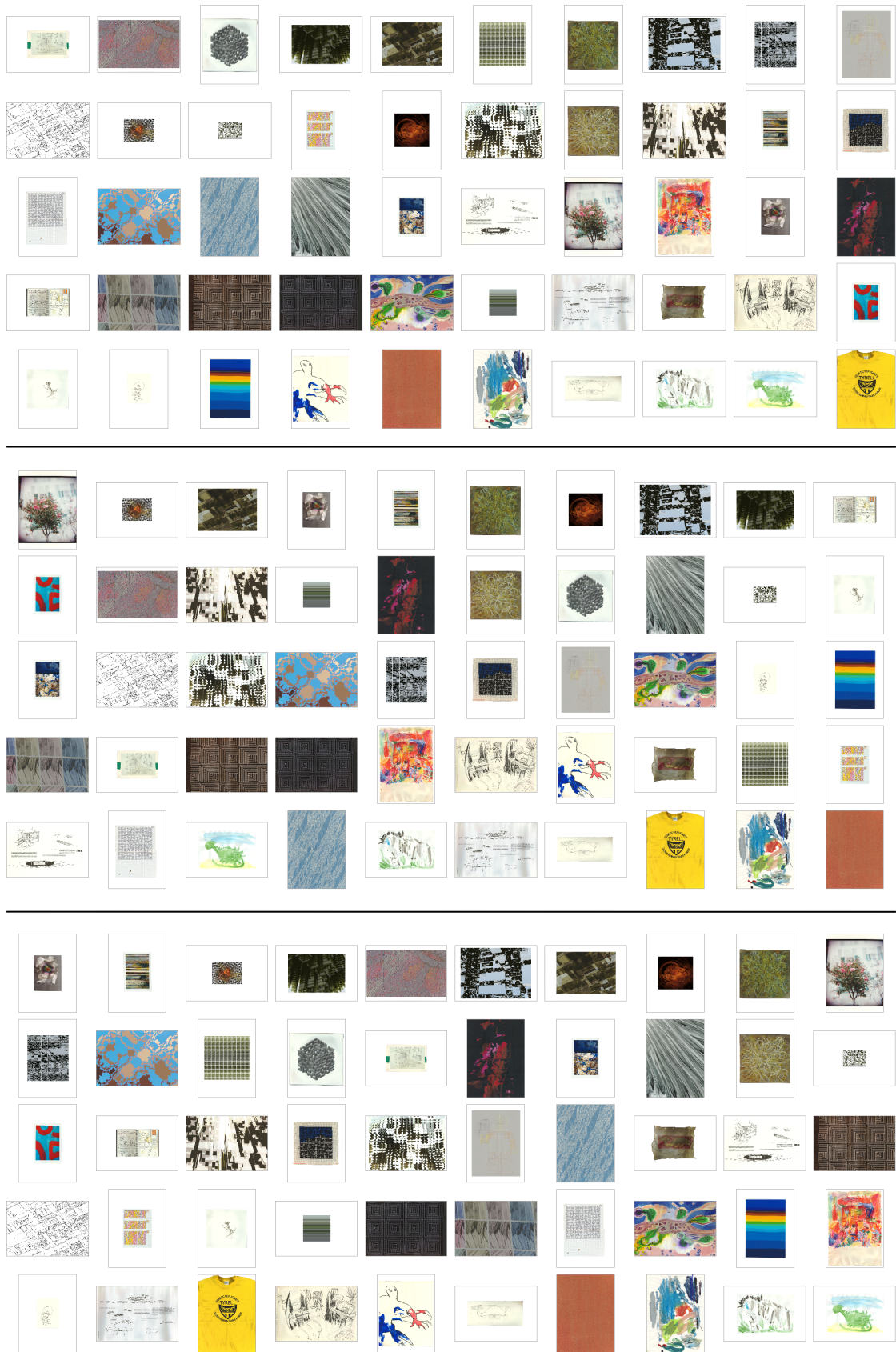

Figure 91. Images arranged by geometric mean scores of complexity (top), preference (middle) and quality (bottom) for Test 3b.

## Correlations

The correlations between objective measures of complexity and subjective aesthetic judgments are shown in Table 21. The table includes data for the two different complexity measures – one based on actual file size and the other on the virtual compression ratio. Absolute file size measure appears to perform slightly better than the virtual compression ratio, which goes against our expectations. Overall, however, there is practically no linear correlation between these scores, and this too counters what we might have expected from Donderi’s results. The correlations with compression ratio are also illustrated in Figure 92.

Subjective ratings (geometric mean)	File size (actual)			Compression ratio (virtual)		
	TIFF	PNG	JPEG	TIFF	PNG	JPEG
Complexity	-0.21	-0.20	-0.09	-0.15	-0.18	0.03
Preference	-0.27	-0.26	-0.30	-0.15	-0.15	-0.15
Quality	-0.20	-0.19	-0.19	-0.05	-0.07	0.07

Table 21 Correlations between subjective ratings and objective image complexity.

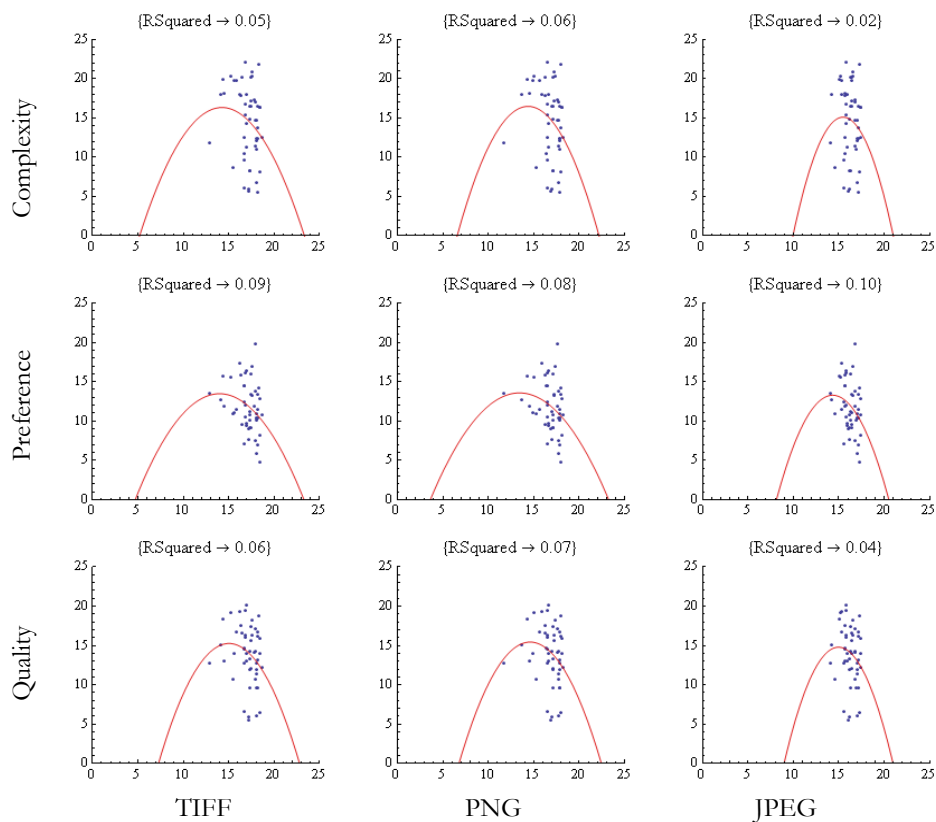

Figure 92 Test 3b: plots of log file size ( $x$ -axis, bytes) vs. subjective scores ( $y$ -axis).

Figure 93 illustrates regression analysis for subjective ratings plotted against compression ratio. From these graphs, we can see that JPEG file compression gives a narrower range of compression ratios than the other two file types, most likely because it is a lossy algorithm. JPEG converts RGB colour channels into luminance ( $Y$ ) and chrominance ( $Cb$  and  $Cr$ ) channels, and then discards more of the colour data to which we are less visually sensitive than luminance (Salomon 2004, p.329–334). Even though the JPEG algorithm was designed to take advantage of the peculiarities of the human visual system, it remains to be seen how this should affect its correlation with subjective judgements of complexity since its performance is not significantly better or worse than the other two file-types thus far.

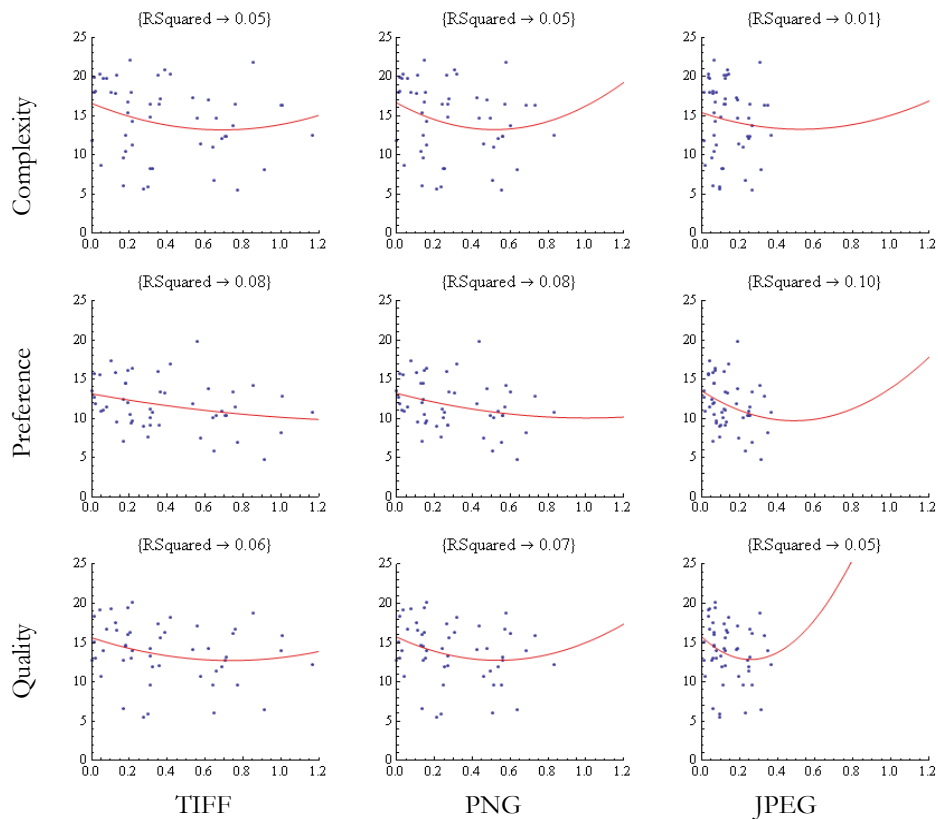

Figure 93 Test 3b: plots of compression ratio ( $x$ -axis, no units) vs. subjective scores ( $y$ -axis).

The weak negative correlations are what we might expect to find if we knew that the stimulus images were generally approaching randomness, such that the images were rated



high in objective complexity, and lower in subjective judgements. If we were correct in assuming a threshold of perceptual complexity at a compression ratio of around 0.5, the fact that many of the image files are above this value might go some way to explaining the result. This is certainly the case for the TIFF and PNG files, but not for JPEG, whose files have compression ratios no larger than 0.4. This effect is more noticeable for the virtual compression ratio than it is for the file-size measure.

The virtual compression ratio did not perform as hoped. Against our expectation, this supposed solution to the problem of borders actually gives a weaker correlation than the absolute file-size measure. There is still reason to believe that the principle is sound, but in practice, with the weak correlation in the present results, it offers no benefit for the set of images used in this test.

## Test 3 Findings

### Comparing Results between Tests 3a and 3b

We can compare the subjective results from tests A and B by plotting the data together. There are a couple of ways to do this, illustrated in Figure 94. The upper graphs show the geometric mean scores for the two tests. We can see that the scores follow each other quite closely and also that the complexity scores are slightly higher for test A. The lower set of graphs shows the correlation between the two tests, and the red lines show the best fit. If two ratings are of equal ranges, then the line will fit a 45 degree slope, whereas if the scores differ significantly the line will deviate from this angle. The slope of the graphs shows that only complexity ratings differ appreciably between the two groups of participants.

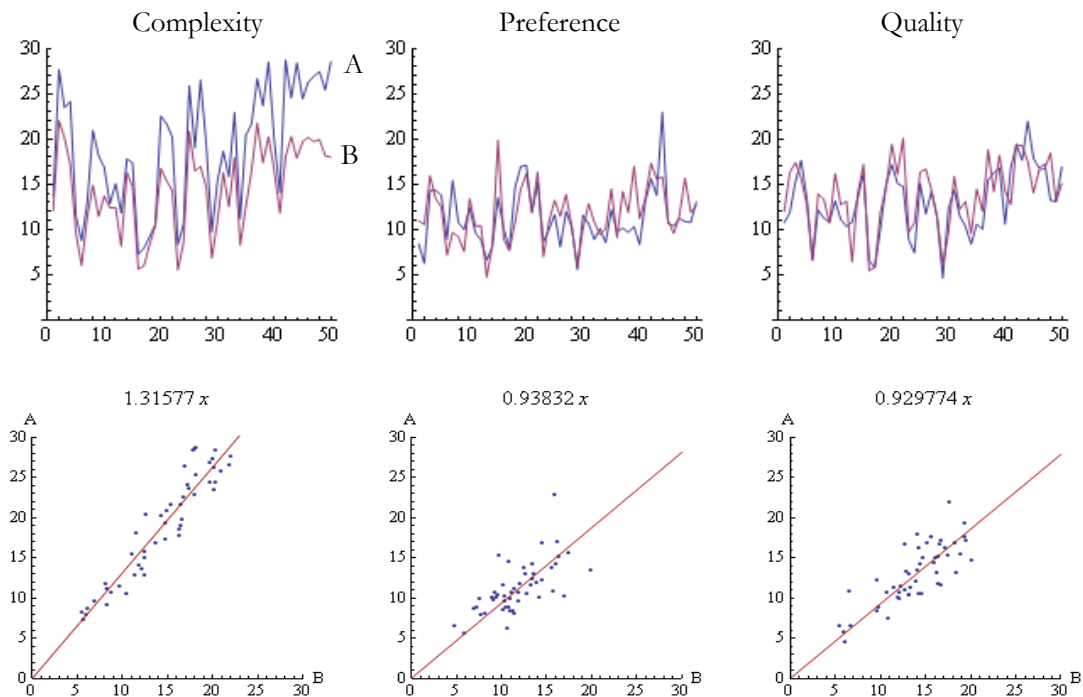

Figure 94 Top row: Comparison of test 3a (blue) and 3b (red) results for complexity, preference and quality ( $x$ -axis: rank order file size, no units;  $y$ -axis: GM scores, no units). Bottom row: Correlations of geometric mean scores between tests A and B.

The two tests correspond with each other insofar as they tend to agree on the relative complexity of images (i.e. participants agree which are the most and least complex images), but the scales of numbers used to represent perceived complexity are higher in test 3a. In other words, participants perceived more complexity in test 3a. One reason for this difference may be that the images were viewed more closely in test 3a where images were presented on tables than in 3b where the images hung on walls. This result discounts the hypothesis that the test setting would not affect aesthetic judgements. It also suggests that perceived complexity is more sensitive to environmental variables, such as setting and viewing conditions, than the judgement of preference and quality which is likely to be more dependent on subjective variables amongst the participants.

Table 22 compares correlations of subjective ratings for the two tests. It reveals a similar pattern of results for each, with the strongest correlation between complexity and quality and the weakest between complexity and preference. The consistency between these

results from tests in different locations implies that we can be confident in the collected data, whilst the strength of the correlations indicates that there are shared criteria being employed in these aesthetic judgements. Interviews with test participants elaborate these findings by examining the criteria employed in the tests, which is presented in next section.

Complexity			Complexity		
0.27	<b>A</b>	0.73	0.54	<b>B</b>	0.81
<b>Preference</b>	0.66	<b>Quality</b>	<b>Preference</b>	0.81	<b>Quality</b>

Table 22 Correlation between subjective ratings for tests 3A (left) and 3B (right).

To find out whether there is a significant difference between the two tests, we perform a t-test. The results of this and other statistical tests are included in Table 23.

Subjective ratings (geometric mean)	Correlation	Mean difference	T-test statistics	
	r		t	p
<b>Complexity</b>	0.94	4.54	3.95	0.0001
<b>Preference</b>	0.66	-0.49	-0.78	0.44
<b>Quality</b>	0.80	-0.84	-1.12	0.26

Table 23 Statistics for data of tests 3A and 3B. T-test is two-sided,  $p = 0.01$ .

Considering that these two tests took place at different times and locations with many different participants, there is a surprising consistency in the subjective responses. The strongest correlation between the two tests is found in the complexity ratings. Nevertheless, there is a significant difference in complexity ratings between the tests ( $r = 0.94$ ,  $d.f. = 56$ ,  $p < 0.01$ ), but not for the other two ratings. The  $r$  value describes the consistency in the pattern of the rating, whereas the  $t$  value describes the difference between the ranges of numbers between the two groups. This means that both groups see the same images as being about the same relative complexity, but the scales used are quite different ( $t = 3.95$ ,  $d.f. = 56$ ,  $p < 0.01$ ). Irrespective of the location, the two groups are

rating in a consistent way. It seems that there is a reduction in perceived complexity in the gallery context, where the viewing distance was on average greater than in the psychology laboratory. The relative differences in complexity perceived between the set of images in each location was about the same, but the results suggest that the overall level of detail – or high spatial frequency information – is higher when viewing nearer. Preference remains constant because moving further away reduces the complexity consistently for all the images. The inference is that visual complexity is a function of the amount of visual information available.

## **Combined Results from Tests 3a and 3b**

### **Visualizing Data**

Plotting the graphs in a grid (Figure 92) allows us to see the difference between file types and between ratings, but because it is based on averages it fails to reveal any detailed patterns within the data. More detailed patterns can be found by representing the full data set in another way, using colour. Figure 95 represents the entire data set for Tests 3a and 3b combined. There is one coloured square plotted for each image (50 columns) and each participant (58 rows) for each of the three rating scales. This makes a total of 8,700 data points, in a data set with 5 dimensions (participant, image, rating type, file compression, and rating score). In each plot the image columns have been arranged in order of increasing file size from left to right. The colours represent the magnitude of the scores – red for high and blue for low.

The value of this basic form of data presentation is that it allows us to use our powers of visual perception to look for patterns in the data (order in the chaos). If participants' scores corresponded with file size, we would see the colours arranged in a spectrum from cool on the left to warm on the right. Here, there is only a slight tendency in the opposite direction noticeable for complexity, which reflects its weak negative correlation, and there is no obvious pattern in either of the other images. The visible structures in Figure 95 reflect quantitative patterns in the data. Horizontal regions of colour

indicate similarly-rated images for a single participant. Vertical regions of similar colours indicate agreement between participants' ratings, and these patterns are the more important for the present study, since differences between individuals are later averaged out in statistical analysis. However, there is actually very little structure in these images, which is a direct reflection of the lack of order in the data; compared with the more obvious patterns of data from test 2 (Figure 80) these images are quite disordered.

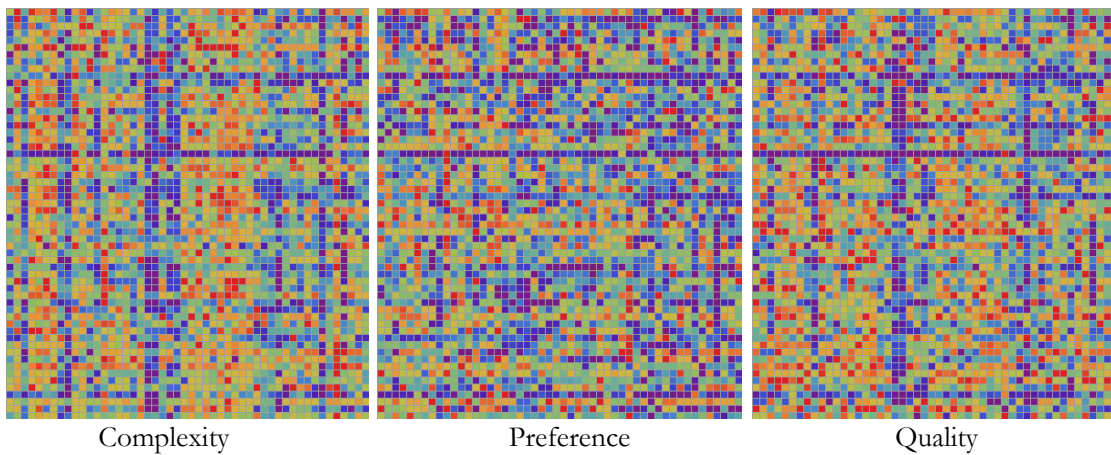

Figure 95 Representation of combined data from test 3A and 3B.

Even though the lack of patterns in the data means that unfortunately we can tell very little from the statistical results, we can visualize the rank order of the stimulus images as arranged by the average subjective ratings of complexity, preference and quality (Figure 95). This allows us to see what the quantitative data cannot tell us – namely, the *type* of image as well as its placing in the rankings. The paintings of a dinosaur and a zebra by my three-year old nephews, Oliver and Isaac Avison, are placed low in ratings of complexity and quality, but Oliver's dinosaur image is notably higher in preference – a detail supported by a few of the test participants who commented in interviews that they had rated it highly because it was charming. Two other notably childish or amateurish-looking pieces (an image of Spiderman and an abstract painting) are also scored low for all three ratings.

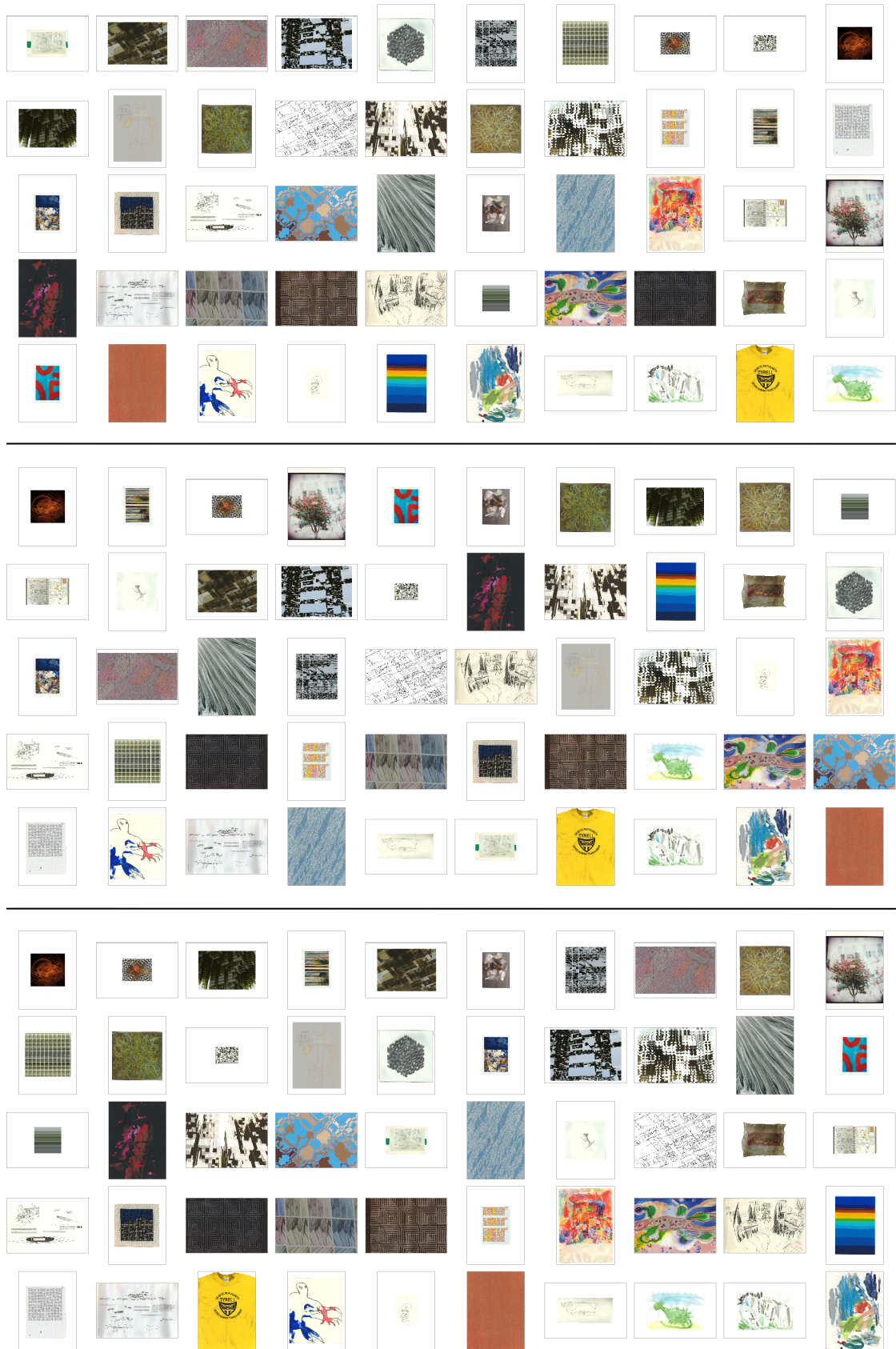

Figure 96 Images arranged by geometric mean scores of complexity (top), preference (middle) and quality (bottom) for combined results of tests A and B.

The most complex rated image is a drawing by Bommsoon Lee, and the majority of the images in the top twenty rated as most complex are my own which aimed for the threshold of visual complexity. The image rated highest for both preference and quality is one I created with Draves' *Fractal Flames* algorithm, which did rather resemble a flame with its curling red and orange irregular fractal forms. It is interesting to note that the repetitive patterned textiles were not rated amongst the most simple. A blue and white 'non-repeating pattern' textile is rated as medium complexity, whereas a similar orange textile with less contrast is rated far lower, suggesting the perception of an overall texture in the latter case which lowers its perceived complexity.

When the data from test3a and 3b are combined, the strongest correlation between subjective ratings is found between complexity and quality (Table 24). The correlation between quality and preference is very similar, which is what we have come to expect, because people tend to like the things that they perceive to be good. That between preference and complexity is around half as strong, in line with the results of previous tests.

	<b>Complexity</b>	
	0.42	0.80
<b>Preference</b>	0.78	<b>Quality</b>

Table 24 Correlations between subjective ratings (geometric mean scores) for tests 3a and 3b combined.

Regression analysis for the combined results of Tests 3a and 3b are illustrated in Figure 97. The coefficient of determination ( $R^2$ ) is a value between 0 and 1 that expresses how well the predicted values match the actual data. Given that there is almost no correlation between objective and subjective measures of complexity in our data, we are unlikely to find a good fit to the data. Although graphs in Figure 97 appear to show an inverted U shape, the poor correlation and weak R squared value means that there is

practically no relationship between the file compression measure of complexity and these aesthetic judgements. This is also clearly seen in the distribution of data points.

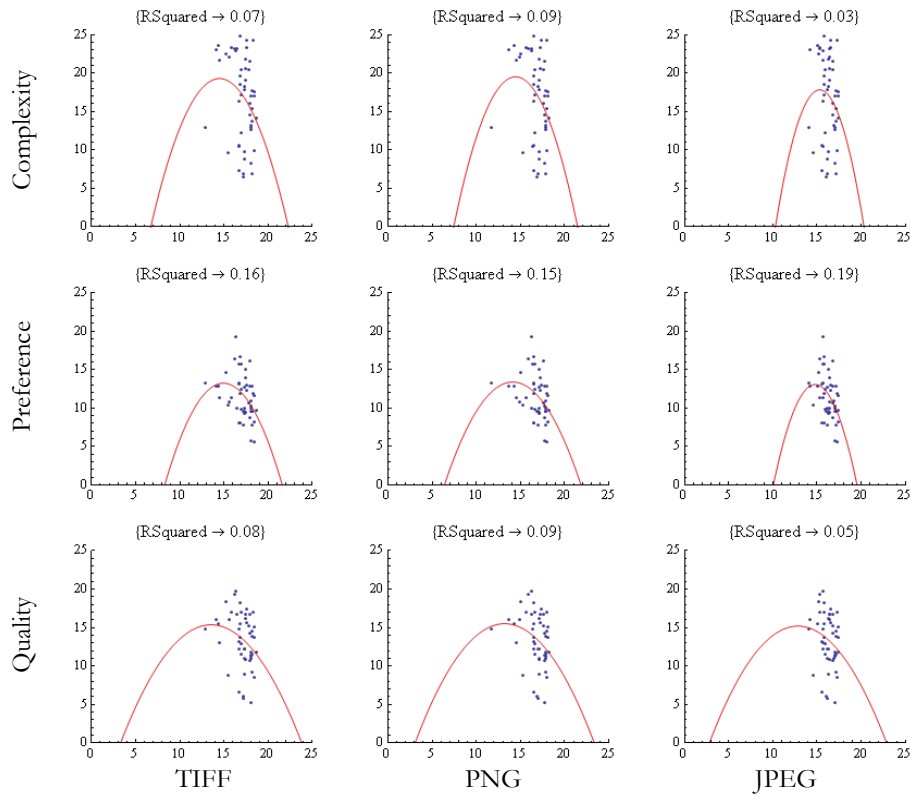

Figure 97 Plots of compression ratio vs. geometric mean scores (no units).

The analysis in Table 25 shows what we expected: Each pair of objective and subjective scores has an  $R^2$  value less than 0.1, which means that the best-fitting equations fail to estimate our data, probably because it is so poorly correlated. Similar results are found for first, second and third-order polynomials. This means that the file compression measure of visual complexity has failed to work with these images from art and design, unlike its success with the sets of cellular automata and random images in the previous tests. The likely reason for the poor correlation with this sample of images is due to their great variety. Whilst this variety was one of the test objectives, with the aim of representing a wide range of visual complexity, the difference between types of media and styles of artwork appears to have provided extra variables that have masked the relationship between file size and aesthetic judgements that we found in the earlier tests on more homogeneous visual material.



Subjective ratings (geometric mean)	File size			Compression ratio (virtual)		
	TIFF	PNG	JPEG	TIFF	PNG	JPEG
Complexity	0.051	0.053	0.012	0.072	0.075	0.080
Preference	0.084	0.083	0.096	0.023	0.023	0.021
Quality	0.061	0.065	0.045	0.024	0.027	0.051

Table 25 Coefficients of determination for subjective ratings and objective measures of image complexity.

### Artists vs. Non-Artists

Comparative graphs of the combined Test 3 data for art-trained and untrained groups of participants are presented in Figure 98. The slopes indicate a significant difference for all three ratings, with art-trained participants rating consistently higher.

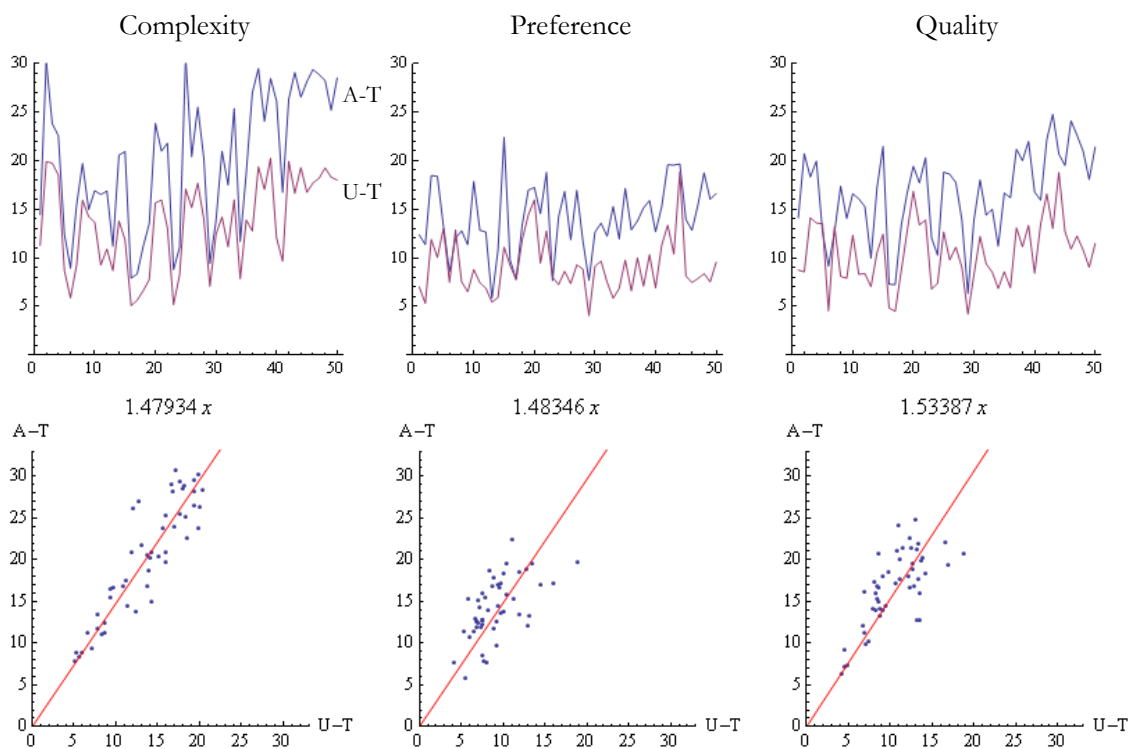

Figure 98 Art-trained (blue / A-T) and untrained (red / U-T) ratings for tests 3A and 3B combined. Top: rank order file size ( $x$ -axis, bytes) vs GM scores ( $y$ -axis, no units). Bottom: Correlations between art-trained and untrained participants.

The results of statistical tests are presented in Table 23, which confirms that all three ratings are positively correlated between art-trained and untrained participants, with a

strong correlation for complexity ratings ( $r = 0.90$ ) and a weaker correlation for preference ( $r = 0.59$ ). There is a significant difference between the groups: art-trained participants gave consistently higher scores for all three ratings (e.g. for complexity  $t = 5.66$ ,  $d.f. = 56$ ,  $p < 0.01$ ). This finding is unexpected. We found in Test 2 that artists rated higher for preference alone, and we find it hard to explain this result when it might seem reasonable to think that the artists' greater exposure to visual material and familiarity with aesthetic judgement would result in more critical, lower ratings overall. Test 2 findings also suggested that perceived complexity is less variable than judgements of preference, but this is cast into doubt with the results of Test 3. We are thus unable to account for the finding that art-training appears to correspond with higher ratings for all three aesthetic judgements – complexity, preference and quality. It is possible that art training equips an art audience with more criteria with which to find virtue in images, or that it relates to a greater capacity to perceive aesthetic information and a greater aesthetic sensitivity.

Subjective ratings (geometric mean)	Correlation	Mean difference	T-test statistics	
	r		t	p
Complexity	0.90	6.65	5.66	$2 \times 10^{-7}$
Preference	0.59	5.05	7.81	$8 \times 10^{-12}$
Quality	0.72	6.15	7.91	$6 \times 10^{-12}$

Table 26 Statistics for data from the art-trained and untrained participants. T-test is two-sided,  $p = 0.01$ .

## Hypothesis Evaluation

We return to the test hypotheses to see how they fared in light of the test 3 results:

1. *Image file compression will correlate with judgements of complexity.*

We failed to find any notable correlation between file compression and judgements of complexity. It seems that the sample of visual material in this test was so varied that it masked the correlation with file compression that was found in earlier test results.

*2. Familiarity with art and design will correspond with lower ratings of complexity.*

We found the reverse in Test 3, in which ratings by art-trained participants were consistently higher on average than untrained participants, not just for complexity but for judgements of preference and quality also.

*3. The test environment will not affect aesthetic judgements.*

The results show that the test location significantly affected only perceived complexity, and not judgements of preference and quality.

## **Summary**

Overall, the results of Test 3 are quite negative: they failed to support any of the three hypotheses or show a significant correlation of compressed file size with aesthetic judgements of complexity, preference and quality. The poor correlation is not what we expected, given the results of the earlier tests, but it does make some sense if we take into account the variety of the visual material used for the test stimuli which appears to have masked the previously found correlation. We cannot say at this time whether this means that the file compression measure is unsuitable for art and design images in general or whether it failed only for the sample used in the current project. The relative success of the methods with CA and random images in Tests 1 and 2 suggests that the problem lies with the choice of stimuli in Test 3, and that we should not rule out the file compression method for further testing in future.

Art-experience appears to have increased the overall ratings of aesthetic judgements, a finding we are unable to explain at present, especially as it conflicts with the results of tests 1 and 2 for which art-experience only influenced judgements of preference. The test location significantly affected judgements of complexity, probably due to the difference in viewing conditions: Ratings in the art gallery, where the participants could more easily determine their own viewing distance from the gallery walls, were lower than those of the

closer and less-variable viewing range in the psychology lab. The difference in rating scales is perhaps due to the increased detail that becomes perceivable at closer ranges.

The use of compression ratio as an alternative to the file-size measure of image complexity is demonstrated to be potentially viable, although its effectiveness could be more reliably established with further tests. The advantage of the compression ratio is that it is more informative (it indicates the amount of randomness) and more comparable between tests. In regard to the proposed virtual compression ratio as a potential solution to the problems with image borders, it appears to be sound in theory and it did re-arrange the files as intended, but made surprisingly little difference to results in practice. This is probably due to the variation in stimuli and the low statistical correlation in the present data which likely obscured its potential value in this application.

Despite the poor correlation with file compression, there is a stronger correlation between subjective ratings, particularly between complexity and quality. This pattern is fairly consistent between different test locations and between groups of subjects. The statistical relationship is supported by the interviews with participants who reported the use of similar criteria in evaluating these two aesthetic properties. Both visual complexity and artistic quality are judged in relation to the difficulty of making and understanding an artwork in terms of the time and effort required. This is a significant finding because it constitutes empirical support for the central thesis of this research project, namely that visual complexity is a significant factor in the aesthetic value of visual art and design. The finding therefore makes a contribution to knowledge.

# Chapter 6

## Conclusions

### Summary of Findings

At the beginning of this thesis, we considered the variety of patterns in our local environment. It seems that the size of the area occupied by a particular type of pattern is inversely proportional to its visual complexity. The largest areas, such as sky and walls, have the simplest patterns. Next-most common are likely to be repetitive patterns – either regular (clothing and furnishings), or irregular and chaotic (grass, rock, foliage). The most visually complex artefacts are likely to occupy the smallest areas. This relates to the information theory conception of complexity in terms of probability and predictability. Information is quantified in terms of its predictability, and complexity is less predictable than order. By this conception, however, randomness is less predictable and so it has greater statistical information than complexity. Therefore an information-based measure fails to describe our intuitive understanding of complexity, which to us has greater meaningful information than randomness. This problem has been central to the current project, and forms the basis of its contribution to knowledge. The following sections provide an account of the ways in which it has dealt with this issue. Firstly, we summarize the findings by answering the research questions, and identify the contribution to knowledge. Then we discuss particular implications of the contribution in further depth, and outline the impact of the research on my art practice. Finally, we identify potential opportunities for future research in development from the current project.

### Answers to Research Questions

In this section, we collate the findings of this project by answering the research questions which were formulated at the end of the first chapter (discussed pp.10–13 and

listed p.46). The following sections are grouped as were the research questions, by the research stages adapted from the model of Phillips and Pugh (2000).

### **Focal Theory**

Visual complexity appears to be interesting because the perception of complexity is a demanding perceptual task. Faced with a complex visual array, we engage in perceptual processes such as edge-detection and pattern-detection, and since visual complexity is related to the quantity, variety and order of perceived edges and patterns, a more complex image may provide a more satisfying aesthetic experience. The reason for the high complexity amongst artworks may be that artists made this discovery intuitively and worked to take advantage of successful experiments in visual complexity. Certainly, the evidence of Pollock's gradually-increasing fractal complexity in his drip paintings would support this idea. Another reason for complexity in art may stem from the representation of the natural world, which contains complex patterns of many varieties. On the other hand, non-representational art tends to be less visually complex, and is none the less aesthetically valuable for it. We identified minimalism as the movement that most closely associates its theory and practice with the concept of aesthetic complexity, albeit with the result of a reduction towards the simpler end of the spectrum.

The study of contemporary art practice indicates that minimalism is manifest at various stages of the creative process, and also that simple processes can produce complex aesthetic perceptions. These finding appears to have been made almost concurrently in empirical aesthetics and in the arts shortly after the introduction of information theory, as evidenced in the work of Attneave, Moles, Bense and Nake. From information aesthetics also came the complementary realization that detailed randomness or chaos can produce perceptual effects of simple textures, an idea which is incorporated in Bense's micro-aesthetics and is currently employed by contemporary musicians and visual artists such as Carsten Nicolai and Mark Fell. The concept of aesthetic information thus provides as useful a framework for creative approaches to the production and perception of visual

complexity as it does for the scientific approach, for which it offers a scale of measurement than can be applied to aesthetic properties and perceptions.

### **Contextual Theory**

Complex systems theory generally understands complexity as the difficulty of making or describing something, and it measures this difficulty in terms of time, effort or cost. A more complex object takes more time or effort to describe, and so the size of a description is an indication of complexity. Donderi's (2000) file compression of digital image files constitutes a basic measure of complexity which equates to the shortest description of an image based on an array of coloured pixels. We identified the fundamental components of visual complexity as being the quantity, variety and order of visual elements, and these are exactly the properties encoded by digital image files, which describe the number, colour and arrangement of pixels. Quantity and variety of elements have a simple proportional relationship to complexity, whereas order is a more subtle matter. Because the file-compression measure is based on the information theory concept of redundancy, the scale of order it furnishes is a measure of randomness (entropy, redundancy, and incompressibility). This means that the file compression measure does not accord with our intuitive notion of complexity, because we perceive randomness as a simple texture, for example. The hypothesized relationship between the compression of image files and the perception of visual complexity, made by Wolfram (2002) and Donderi (2006a), suggests that we should find an inverted U correlation. Donderi and McFadden's (2004) and Besner's (2007) experiments failed to provide evidence for this hypothesis and left a gap in knowledge.

Whereas empirical aesthetics is a small but flourishing area of current research in perception, contemporary aesthetic discourse has disengaged with perception in its theory and to some extent in its practice, such as in Bourriaud's relational aesthetics (2002). The model with currency in today's artworld is the institutional theory, which successfully defies the neo-Wittgensteinian challenge of defining art posed by Weitz (1956). Dickie's art circle

(1997) does this by describing the mechanism of the artworld rather than the properties of artworks, but it does so at the expense of providing a satisfying explanation to the significant aesthetic questions of why we value art and what counts as aesthetic value. Part of the justification for the focus of the current project is to re-assess perceptual aesthetics, concentrating on the aesthetic property of visual complexity. The justification for investigating complexity is that it captures much of the essential information in pictures because it is based on the fundamental attributes of quantity, variety and order of picture elements.

Research in vision shows that the perception of complexity largely depends on pre-conscious processing in the retina, where the edge-detection mechanism of receptive fields of photoreceptors ultimately gives rise to the perception of recognizable shapes. Marr (1982) formulated an understanding of vision in terms of the information-processing of edge-detection and the formation of visual percepts, which allows for a computational approach to aesthetic perception. Marr's perceptual theory provides a framework that justifies the computational approach of Donderi and McFadden (2004), and thus supports this project's methodology which employs the file-compression method pioneered by Donderi.

### **Data Theory**

The methodology aims to approach both sides of the aesthetic identified in the working model – the sites of aesthetic production and perception. Aesthetic production is approached through creative experimentation in art practice and by collecting samples of contemporary work from artists and designers. Aesthetic perception is approached empirically by using the visual material created and collected as the basis of stimuli in aesthetic tests. With this material, we can measure both objective and subjective complexity, and test the hypothesis of the inverted U correlation between information-based and perceived complexity. We aim to identify whether there is a perceptual threshold to visual complexity by mapping the perception to a wide spectrum of complexity using



cellular automata and random images. Later tests use images of the collected artwork to establish whether the measure would work for the aesthetics of art and design. The design and execution of the tests gain validity from the success of trials with the aesthetic measures. Although the ability to transfer conclusions back to the larger population is restricted by the small sample sizes in these tests, they are sufficient enough to be confident in the results obtained, as evidenced in the statistical analyses, and are comparable to a number of the professional empirical studies cited in this thesis.

The results of the first two tests with CA and random images show strong evidence for the hypothetical inverted U correlation between image file compression and perceived complexity. In Tests 1 and 2 there is little sign of a unified response to preference for levels of complexity, with only a slight preference for higher complexity amongst art-trained participants. There is a significant difference in ratings between art-trained and untrained participants, with artists rating higher for preference in Test 2. In Test 3 artists rated higher for all three ratings.

The two locations of Test 3 appear to make a significant difference to complexity ratings but not to preference or quality. Complexity ratings are highly correlated in the *ranking* of images between tests 3a and 3b, but the *scales* used by participants are significantly lower in the context of the art gallery (Test 3b), which implies that more visual complexity is perceived at the closer viewing distance in the psychology lab (Test 3a). Overall, the file-compression measure fails to reveal a significant correlation with any of the three aesthetic ratings in Test 3. Nevertheless, the correlation between subjective ratings indicates a positive connection between visual complexity and aesthetic value, whether or not it involves conscious perception. This finding is supported by the qualitative analysis, which identifies the criteria behind the aesthetic judgements of complexity and quality. The interview analysis also supports the idea that complex images engage us because we have to work at understanding them and because we find pleasure in this task – we are rewarded aesthetically for the perceptual effort. The results of the

qualitative analysis suggest that we find complex images rewarding because it is related to the understanding that visual complexity is evidence of skill and effort on the part of the maker.

## **Contribution to Knowledge**

The material critically reviewed in this study constitutes a mapping of contemporary aesthetic practice relating specifically to the area of visual complexity. The review presents an organised account of theory and practice across the boundaries of three fields: philosophical aesthetics and art discourse, empirical aesthetics, and art practice. A contribution to knowledge is made with this up-to-date mapping of visual complexity which integrates knowledge from separate disciplines and applies it to current understanding of art and design practice. An argument is made for the re-assessment of perceptual aesthetics, with the view that it has the potential to supplement the weak explanatory power of contemporary aesthetic theories of art. The argument is supported with empirical evidence, which takes the form of the following contributions:

The results of the first experimental trial with the file-compression measure of complexity on images of cellular automata reveal a direct connection between this information-based measure and schemas of complexity from systems theory. The reasons for the correspondence lie in the equivalence of the underlying scales in terms of measuring complexity by difficulty of description. Although this finding seems almost trivial given the wide understanding of these principles, it nevertheless makes a small but original contribution to knowledge by providing clear empirical evidence for the relationship between these two specific concepts of complexity, and possibly constitutes the first measurement of cellular automata programs by the file-compression method.

Test 1 and Test 2 provide empirical evidence for the hypothetical inverted U correlation between file compression and perceived complexity. Against the findings of Besner (2007), which were interpreted as inconclusive, these results constitute an original

contribution to knowledge, as being the first hard evidence for this correlation. We found no strong evidence for a similar correlation between visual complexity and aesthetic preference with the images in these tests.

It was assumed that Test 3 would similarly prove the effectiveness of the file-compression measure for images from art and design, as it had in the case of CA and random images, but the results fail to support this idea. There was no evidence of the correlation of objective visual complexity and subjective aesthetic judgements, which indicates that either the measure may not work for art and design, or simply that it failed to work with the sample in this test. Given the success in earlier tests, the latter is deemed to be the more likely explanation. Nevertheless, we did find evidence of a relationship between visual complexity and aesthetic value, based primarily on the correlation of subjective aesthetic ratings. This is supported by evidence of shared evaluative criteria being employed for judgements of both complexity and quality, based on the analysis of participant interviews. Against the failure to find meaningful results from the file-compression measure, the findings of this relationship between visual complexity and aesthetic value constitute another contribution to knowledge.

Through the quantitative analysis, we find a positive correlation between the objective measure of visual complexity (based on the data compression of image files) and the subjective perception of complexity (measured with MES). We also find a correlation between subjective ratings of visual complexity and aesthetic value ('quality'). Although we can determine fairly precisely the strength and direction of these correlations, the statistics tell us nothing about the reasons why. The qualitative analysis sheds light on the matter by indicating that there are shared criteria between complexity and quality. It suggests that the aesthetic properties that constitute the perception of complexity are interpreted as signs of skill, effort or difficulty in the *production* of an artwork and, further, that visual complexity also involves skill, effort or difficulty in its *perception*. The understanding of visual complexity in terms of the difficulty of its production and perception also relates to the

file-compression measure, which we can understand as a measure of the difficulty of description. This is because it is a measure based on the size of the shortest possible description which is in turn based on the quantity, variety and order of pixels (how many, which colours, and where). The qualitative analysis reveals that a majority of the criteria involved in the perception of complexity can be classified in the same terms, namely the quantity, variety and order of picture elements.

In summary, the knowledge we have gained about visual complexity in this project can be characterised as a theory which is both descriptive and explanatory. The theory allows us to organise our understanding of visual complexity and to use this knowledge in predicting how a given image will be perceived, which has applications for both empirical and creative approaches to complexity. In this way, the study's contribution to knowledge serves as the basis for action in both the scientific analysis and the creative exploration of the aesthetics of visual complexity.

# Implications

## Measures of Complexity

With our current understanding of visual complexity, we can try to integrate some of the key theoretical models cited in this thesis, in particular the various measures of complexity and their relation to aesthetic perception. From the combination of Dodgson's (2008) and Attneave's (1959b) findings, we have the suggestion that in terms of the spectrum of complexity measured by file compression ratio, there is a region of visual appeal between the values of 0.2–0.5, or around one fifth to one half randomness. In addition, this region appears to include a perceptual threshold beyond which we cannot identify structural regularity. The region of visual appeal is illustrated in Figure 99, in conjunction with Langton's (1990) lambda parameter graph with Wolfram's (2002) four complexity classes mapped out. The figure also shows black and white images of elementary cellular automata arranged in order of increasing file size from left to right. The

leftmost image is a uniform black, the images in the centre are cellular automata patterns, and the image on the right is random. Arrows from these images indicate their approximate distribution on the scale of complexity measured by compression ratio and also their position relative to Langton and Wolfram’s mapping of complexity classes.

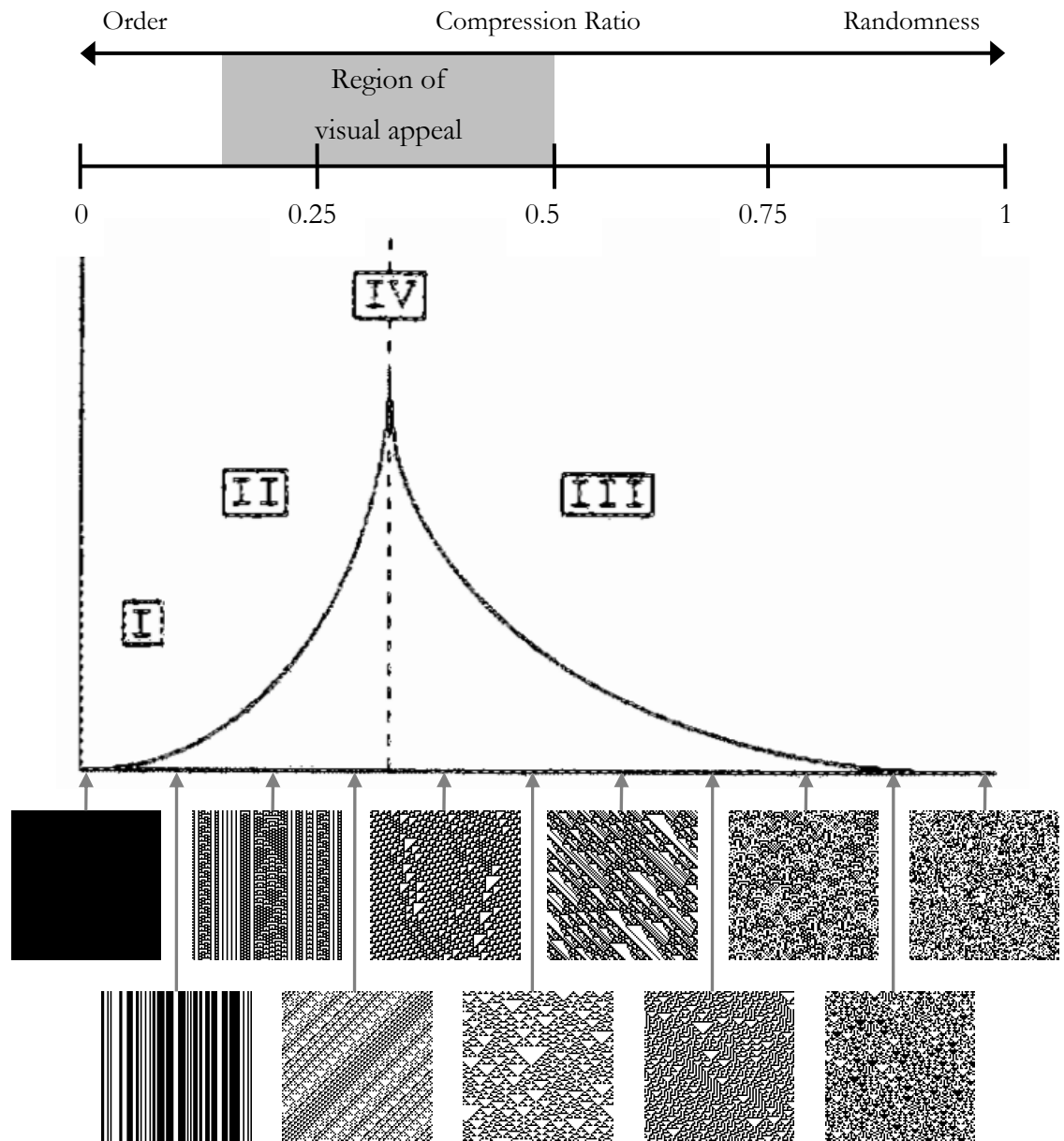

Figure 99 An informational scale of order–randomness and compression ratio (top), Langton’s lambda parameter with Wolfram’s complexity classes (middle), and corresponding examples of elementary CA images (bottom).

One of the findings of this project is that by simply sorting these images by file size, we end up with an arrangement identical to Langton's and Wolfram's maps of complexity. Figure 99 shows that the positions of the images correspond to the levels of complexity in Langton's graph and to the compression ratio scale above it. This is especially evident when using the same cellular automata that Wolfram used – the relatively simple elementary CA. The results of the trial with the file-compression measure provide empirical evidence of the fundamental equivalence of this information-based scale of visual complexity with measures established in the field of complex systems theory.

If we compare the complexity spectra represented in Figure 99 with the results of this project, there is no such peak in preference for complexity in any of the three tests, but we do find a similar peaked correlation between objective (file compression) and subjective (MES) complexity for the sets of cellular automata and random images. Using the compression ratio rather than the file size allows us to map the results back onto these models. Comparison with the test 2 results (Figure 100, red), which gave one of the best correlations between file compression and perceived complexity, shows a grouping of data points near the lower end of the compression scale and the correlation curve is pushed to the left. The reason for this is probably that these four-colour images produced much smaller files than the uncompressed file size which is used in the calculation of compression ratio. Therefore the range is artificially compressed because in fact the set did include completely random images but they were relatively small (in contrast, many-coloured random images do approach this theoretical maximum file size). The range of file compression in test 3 is much greater (Figure 100, green), but the result is a negligible correlation with perceived complexity, and the illustrated curve fits the data so poorly that it should be disregarded. Nevertheless, the results of tests 1 and 2 still provide empirical evidence for the U-shaped correlation between perceived and information-based visual complexity.

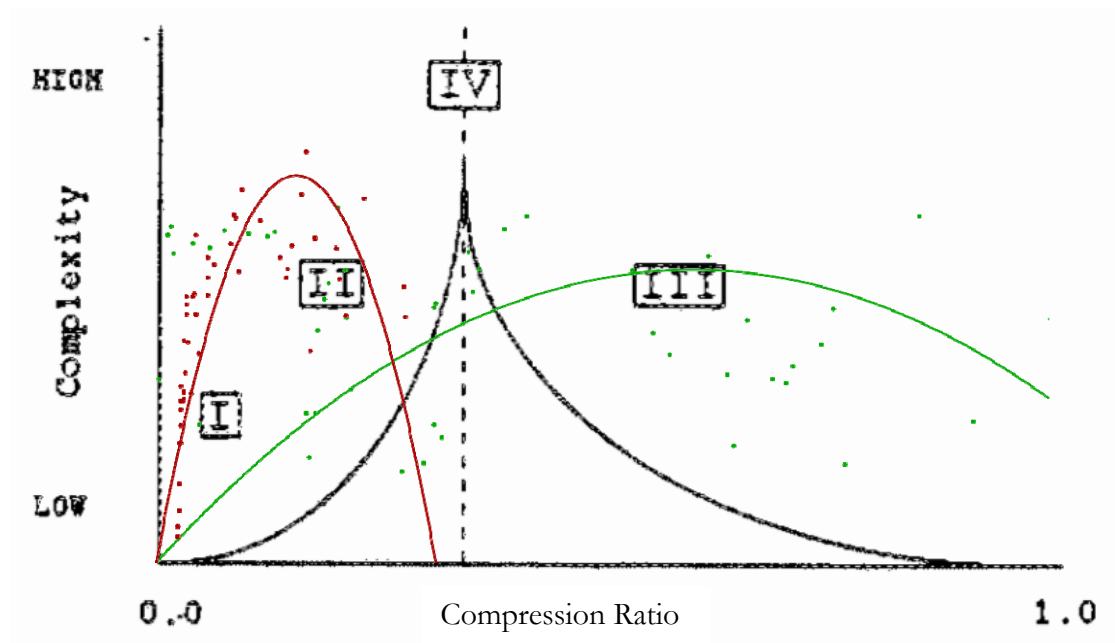

Figure 100 Test 2 (red) and test 3 (green) results – complexity ratings vs. TIFF compression ratio, compared to Langton and Wolfram’s mapping.

## Visual Information

There is a close connection between our understanding of complexity, beauty and consciousness. All three have been described in terms of unity and diversity of visual information: Complexity is a structural unity of many different parts; consciousness – the basis of perception – is a state of unification amongst the diverse areas of the brain (Massimi *et al.*, 2005); and beauty is found in the unified perception of visual elements in a complex image.

In visual complexity, there is also a connection between its perception and its measurement, since both involve pattern recognition. Data compression, which provides the basis of our objective measure of complexity, also involves a form of pattern recognition; repeating patterns of data are redundancies that can be compressed. Not only does this explain why digital image file compression can be used as a measure of visual complexity, but it also suggests that some form of data compression is involved in visual perception. Both Attneave’s “perception as economical description” (1954, p.189) and Wolfram’s account of visual complexity as failure of perception to extract a short

description (2003, p.559) support this idea. An explanation along these lines is required to account for the biology of the visual system: The retina processes visual information from 130 million photoreceptors and sends it to the brain along only 1.2 million ganglion cells in the optic nerve. Somehow, this visual information undergoes a hundred-fold reduction in the process of perception. David Marr's computational model of receptive fields explains how information from groups of sensory elements is processed to higher-order perceptual constructs such as edges and blobs. So it seems likely that this hundred-fold decrease in visual information somehow undergoes a data-compression operation. Whether these processes actually occur in perception, or whether that is merely our best hope of understanding the phenomenon, is a question that may soon be answered as the science of perception advances.

We have seen how information theory offers a crude but effective measurement of complexity. The information-theoretical approach to aesthetics treats visual complexity as an aspect of communication in which the complexity of a message is related to the difficulty of encoding, transmitting and receiving it. This 'difficulty' is quantified in terms of the probability of producing or guessing the message. A statistically unlikely or unknown message has high information content, whereas a probable or predictable message has low information content. 'Message' is an abstract term that can stand for any transmitted information, whether a spoken language or visual material. In this sense, *what information is* is unspecified, yet we are still able to say *how much information* is present in a message:

Information theory measures the amount of information in an observation as the negative logarithm of its probability. Information itself is never rigorously defined; it is only quantified. (Crutchfield, 1990)

The nearest thing to a definition of information is perhaps the one offered by Gregory Bateson: Information is "a difference which makes a difference" (2002, p.459). Only things that make a meaningful difference contribute new information, and this is always relative to the receiver of the information. Bateson considers this understanding of



information to bridge the gap between map and territory, or between representation and reality. Bateson says that perceived differences are “the sort of “thing” that gets onto the map from the territory” (2002, p. 458). We might also say that these mapped features are also *affordances* (Gibson, 1986) because they are the perceived differences which can be acted upon. In terms of visual complexity, the features that are mapped in empirical investigation are those perceivable features of artworks that make a meaningful difference and which can be acted upon in terms of aesthetic judgement. Attneave (1971) understood visual complexity as a property involving comparison (a ‘collative variable’), which therefore depends on the perception of differences: “How complex a pattern is judged to be depends on the existence, extent and direction of differences along its simultaneously presented elements” (1971, pp.106–107). Through the computational approach, we have identified quantity, variety and order of elements as the essential variables in the perception and measurement of visual complexity. These are the critical properties that constitute digital image files, but they are also the most pertinent perceptual features. The relationship between a work of visual art (the territory) and a digital representation of the artwork (the map) is bridged by Bateson’s understanding of information and Gibson’s concept of affordances. The features common to both map and territory are those that are most significant to the map-maker and map-reader.

## **The Spectrum of Complexity and the Window of Visibility**

The computational model of visual complexity developed in this thesis allows for predictions to be generated and tested. It was predicted that with the objective measure of visual complexity (based on image file compression), images at opposite ends of the scale would be perceptually similar, i.e. that the objectively simplest and the most complex images would be perceived subjectively to be equally complex (both perceived as simple images). The relationship between the objective measure and the subjective perception of visual complexity is expressed in graphical form as a curve – an inverted U shape. Findings

in perception research offer an explanation for the U-shape correlation between objective aesthetic properties and subjectively perceived visual complexity:

Campbell & Robson (1968) plotted the contrast sensitivity function (CSF), which is a perceptual threshold based on contrast and spatial frequency (detail). The CSF describes the limits of perception – the point at which details become too small and/or have too little contrast to be perceived. Campbell & Robson used sinusoidal grating images, which vary from black to white in smooth gradations of contrast and spatial frequency. Figure 101 illustrates such an image, with contrast increasing from top to bottom, and spatial frequency increasing from left to right. We perceive contrast only above a certain threshold, and we are more sensitive to middle values of spatial frequency (peaking at around 4 cycles per degree), with the result that the CSF produces a curve which describes an inverted U shape. This curve is not illustrated explicitly in Figure 101 because it varies for each individual, but it can be perceived as the border between the visibly stripy areas and the plain grey areas. We can notice this border changing as we alter the viewing distance; it appears lower at a greater distance. Other animals have greater sensitivity to contrast (for example, cats can see faint shadows that we cannot, so their CSF curve is higher than ours) or have greater resolving power (an eagle's eyes perceive greater detail, which extends the CSF curve to the right), but somewhat surprisingly humans have the best overall CSF with the largest area under the curve. The area under the CSF curve describes the ranges of contrast and detail that we are able to perceive, and it is known as the 'window of visibility'.

In this project's tests, the correlation of objective and subjective visual complexity measures also has an inverted U shape. This result is explained partly by the aspects of information theory and data compression discussed earlier, and partly by the CSF curve. The test stimuli sampled the objective spectrum of complexity from uniform to random. We find that images in the middle of this objective scale are perceived as the most complex. The simplest (uniform) and most complex (random) images, as measured by file-

compression, correlate with the lowest values of perceived complexity. We can now consider these images in terms of the contrast sensitivity function. The simplest possible greyscale image (e.g. made of identical mid-grey pixels), has minimum spatial frequency and minimum contrast, and so it would be located at the top-left corner of the CSF diagram in Figure 101. Conversely, the most objectively complex greyscale image (composed of many different pixels, each of which is a random shade of grey from black to white) has high spatial frequency and high contrast, and so it would be located at the bottom-right corner of the CSF diagram. Therefore, both images lie just outside our window of visibility, which leads to a somewhat surprising conclusion: The simplest image and the most complex image (as defined by an informational measure of complexity such as file-compression) are perceptually indistinguishable from each other.

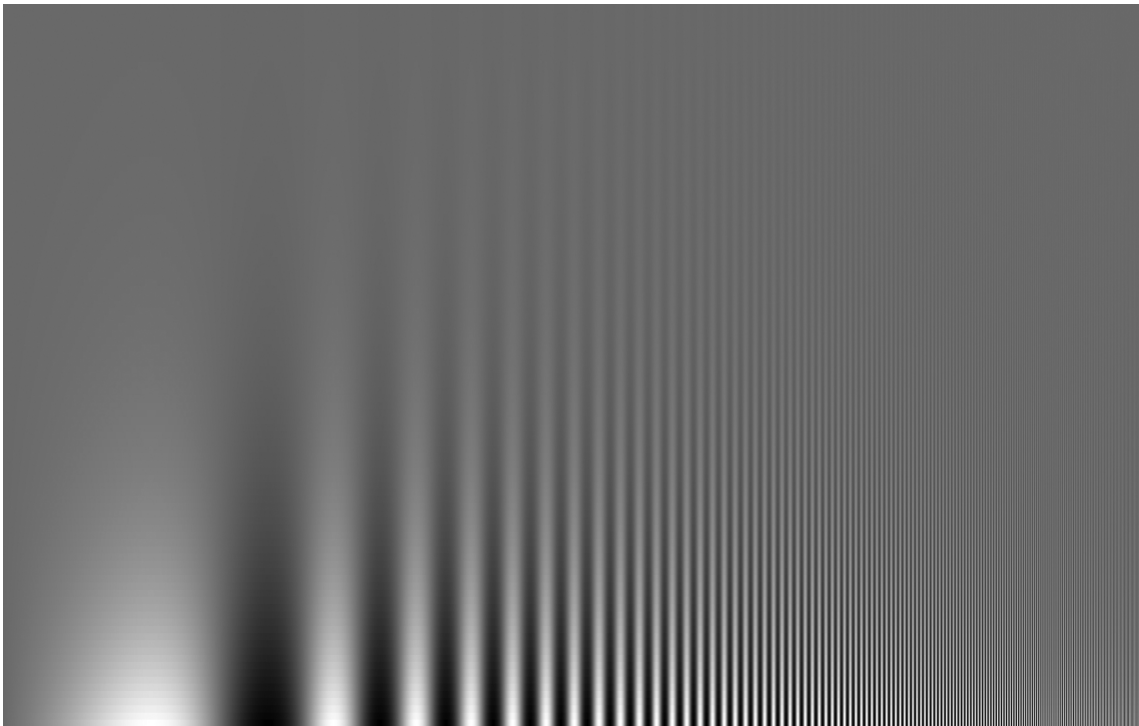

Figure 101 Image showing variation in spatial frequency (increasing from left to right) and contrast (increasing from top to bottom). The areas that appear plain grey are patterns beyond the range of our perception in terms of these two attributes. Generally, the visibly stripy parts appear to form an inverted U shape (the CSF curve), the area beneath which equates to the ‘window of visibility’.

In this thesis, visual complexity is described as ‘a variety of patterns at different levels’. If we understand each possible pattern as having a particular spatial frequency and contrast (that is, as occupying a point under the CSF curve), then the window of visibility describes the range of patterns that are detectable by the visual system and hence potentially available to perception. In the results of our correlation between objective and subjective visual complexity, the inverted U-shape curve of the spectrum of complexity reflects the biological limitations of what is detectable and hence perceivable.

## **The Spectrum of Complexity and Colour Spectra**

With the knowledge that the opposite ends of the informational scale of visual complexity are perceptually identical, we can understand visual complexity in a similar way to the understanding of colour. Like colour, visual complexity is an aesthetic property that has both objective and subjective aspects. Light is really ‘out there’ in an objective sense, and at the same time its phenomenal reality is tied to subjective perception. What we perceive in vision is a range of colours which can be grouped perceptually into ‘reds’, ‘yellows’ and ‘blues’ etc., but visible light is just one part of a much larger spectrum of electromagnetic radiation. Similarly, we perceive a spectrum of visual complexity that has qualitatively distinct phases – order, repetition, complexity and chaos. In both cases, it is possible to measure the spectrum quantitatively – from infra-red to ultra-violet and from simple order to chaotic randomness. The objective colour spectrum can be observed in rainbows and in white light refracted by a prism. The analogous spectrum of complexity is represented by the schemas of Wolfram and Langton, and also by arranging image files in order of their data compression (p.176, Figure 67), all of which have at their core a concept of information. Data compression is actually quite a crude measure, but it is nevertheless particularly useful in organising visual material and in understanding visual complexity.

In both colour and complexity, their objective scales of measurement form continuous ranges with distinct end-points, and yet in perceptual terms these end-points meet: The simplest image is a single block of colour, for example a uniform grey. The most

complex image would be composed of a great number of elements, each of a different colour, ordered randomly. As we discussed above, such an image is perceived as a uniform grey – identical to the simplest possible image. With this kind of perceptual scale, it makes sense to map it out as we perceive it. This is why we have colour-wheels for use in art and design; the circular format of the colour spectrum corresponds to our perception, and it makes more sense to present it this way than in the format of the objective colour spectrum, which is laid out linearly. The implication of this understanding of complexity is that the relationship of objective and subjective complexity is analogous to the relationship of objective and subjective properties of colour. Therefore, colour models are potentially useful in the understanding of complexity, and may perhaps be utilised in creative art practice and in the graphical representation of empirical complexity data.

## **Maps, Measures and Models of Complexity**

To return to measures of complexity, we have found a distinction between information-based measures – such as AIC, MDL, and data compression – and intuitive concepts of complexity – such as Gell-Mann’s effective complexity (EC). This distinction is most clearly expressed with the example of randomness, which is rated high by AIC and low by EC. The results of this project offer empirical evidence for the idea that the perception of visual complexity is more closely related to EC than to AIC: The file-compression measure has been shown to be related to AIC, and performs as we expected, showing a correlation with perceived complexity of ordered images which diverges as images approach randomness. The images with the largest file size and lowest compression ratio appear to be almost random. Although they are rated highest by the objective measure, they are perceived to be fairly simple.

We can understand this situation in terms of Bateson’s definition of information as “a difference that makes a difference” (2002 p.459). A random pattern provides an overall texture to an image that varies greatly from one element to the next, but which is generally quite consistent overall. This relates back to the description in Chapter 1 of randomness as

‘smooth’ variation and chaos as ‘lumpy’. If we were presented with two or three different random images made of black and white pixels, we would probably find it fairly difficult to distinguish between them. From the results we can also conclude that the perceived consistency of random images is dependent on their resolution; greater visible resolution makes a more consistent texture overall. Bateson’s definition offers an explanation for this: The ‘smooth’ differences in random patterns may be perceptually indistinguishable because these consistent differences (between adjacent picture elements) make little difference (overall) to us perceptually. In contrast, what we perceive as a complex image has lots of differences that *do* make a difference. Therefore, a complex image has lots of differentiable patterns at various scales, which are perceived as many interconnected levels of pictorial organisation.

In constructing models of complexity, we must not forget that ‘the map is not the territory’. Bateson’s definition of information acts as a bridging statement between map and territory, between the model and that which is modelled. The things that we map are the perceivable features that make a difference to us. What makes it onto a map is not arbitrary – it is the stuff that actually matters. This is why medical artists are sometimes employed to draw instead of photograph features of illness and disease, because they are able to filter the available visual information and record what is most pertinent and useful for identification and treatment. The significance of Bateson’s bridging statement for this thesis is that the file-compression measure of visual complexity is based on an image file which is in effect a ‘map’ of a visual ‘territory’. The features encoded in this map are the number, colour and location of pixels, which are also the fundamental attributes of visual complexity as identified in this thesis (quantity, variety and order of picture elements), but more importantly they are precisely those features that make a difference to us. The implication is that the current projects’ methods are supported with this understanding of visual complexity and information by providing a theoretical bridge between the modelling or measuring of perception and its action in the real world.

# Impact on My Art Practice

This research project has had a mutually beneficial relationship with my art practice. While the practice supports the empirical research by providing visual material for testing, the research findings have also informed the practice and influenced its direction. In terms of disciplinary areas, my work has grown beyond fine art and towards design for products and decorative arts, while retaining mix of computational designs and craft techniques. My experience with the commissions for the Minster School and the Deutsche Bank, together with the findings of Taylor (2006) that certain fractal values can reduce physiological stress, are stimulating explorations of decorative pattern using cellular automata programs for potential application in workplace environments or even hospitals. The CA images would make a good basis for textile design, since the patterns can be made to repeat, or not, as the case requires. For 3D products, I have plans for a lampshade design based on a CA pattern to be made in translucent coloured acrylic, and a prototype is under construction in Lego bricks which is starting to look more interesting than the original design for laser-cut acrylic (Figure 102).

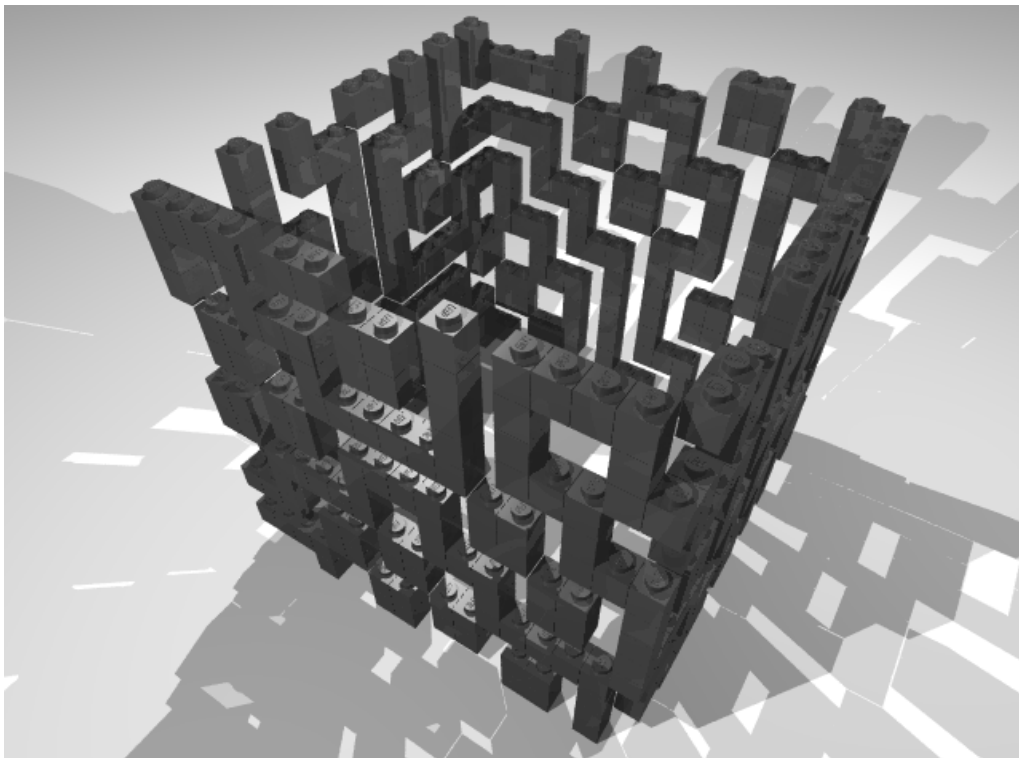

Figure 102 Design sketch for lampshade based on Lego block cellular automata.

Even though I have been an amateur musician for some time, until recently music had never entered my art practice, except indirectly as a soundtrack to its making. In 2008 I showed around twelve artworks in the *Gold Soundz* exhibition curated by Geoff Diego Litherland which was themed around artwork “inspired by music, especially music played with guitars often quite loudly” (Figure 103). In addition to paintings, drawings and prints, which were mostly based on CA programs, my work included a digital animation. The video was based on the Electric Sheep fractals made with Draves’ Fractal Flames algorithm, and the soundtrack was commissioned from Dr. Torben Smith, a chemistry teacher and amateur electronic musician with experience in music for film. Since the animation formed a visual loop composed of three shorter cycles, the requirement for the music was that it should also loop around in time with the visuals. Torben’s music was based on the experience of a cycle of waking and sleeping when hitting the ‘snooze’ button on an alarm clock and the accompanying perceptual distortion of time. The aim of the animation was to explore the perceptual effect of Chion’s (1994) concept of synchresis, which had come to my attention through the contextual mapping in this project. The individual pieces were fine, but in combination the result lacked the synchresis effect.

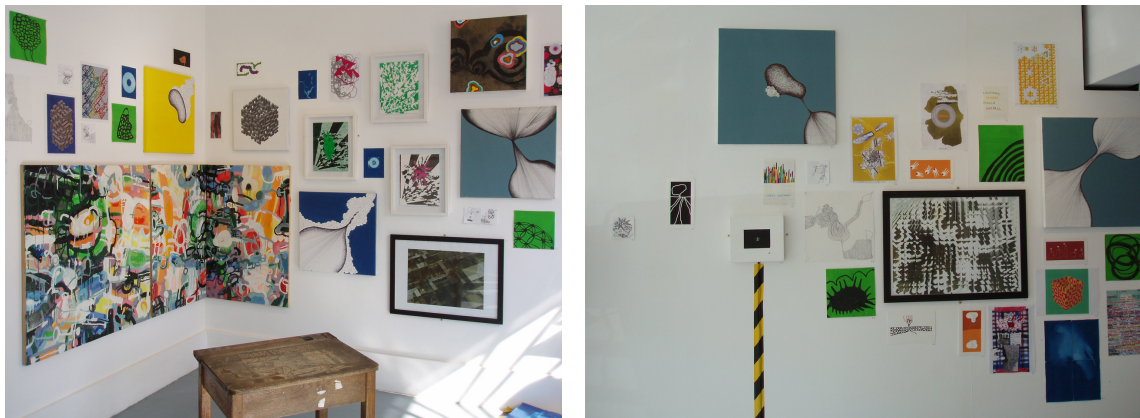

Figure 103 *Gold Soundz* exhibition (September, 2008), Southwell Artspace.

Before working on these animations, my practice had not involved time-based media. The cellular automaton programs employed in the practice do involve an element of time in their computation, but in the artwork up until now this temporal dimension had been transformed into a spatial dimension. This sounds quite abstract, but actually all the images



of cellular automata in this thesis have this property – the vertical spatial dimension represents the temporal sequence of the pattern evolution. In the same way that the evolution of 1D CA is represented in two dimensions, some of my artwork involved representations of 2D CA in three dimensions. In contrast, this latest artwork explores the three dimensions of moving image, which involves 2D space plus time.

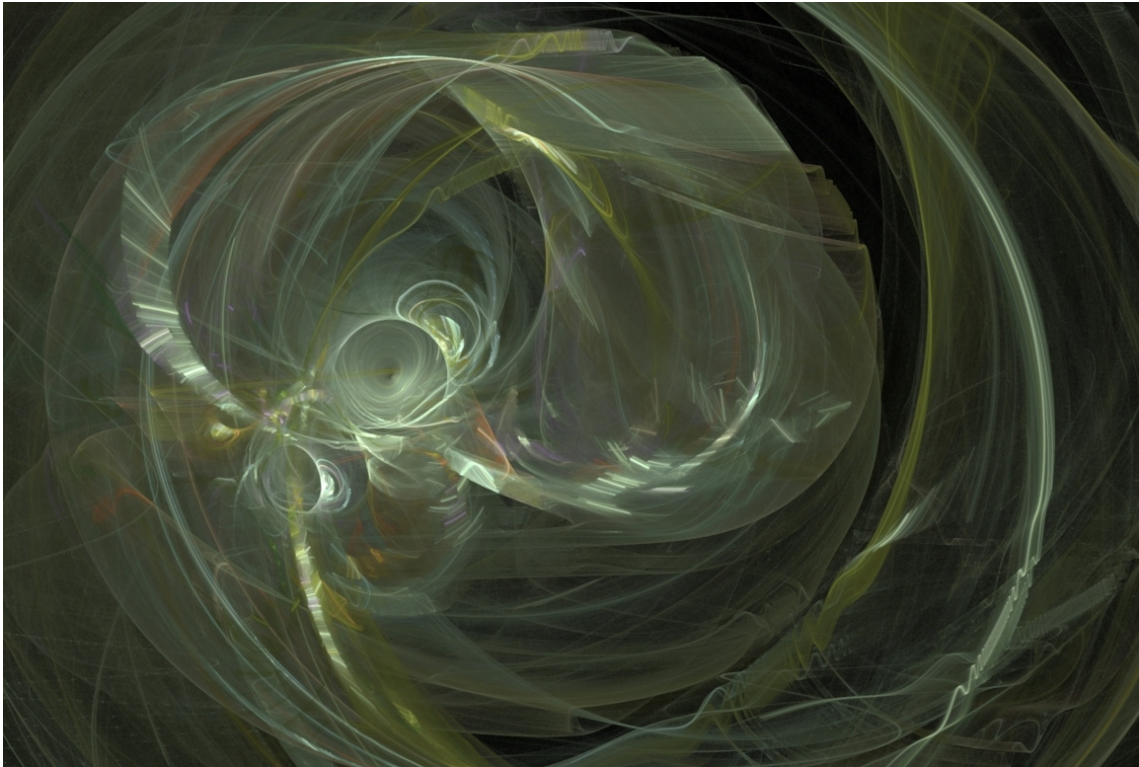

Figure 104  $S[4]n$ , (2009), digital animation, frame 278/9600.

Some of the animations are created with the Fractal Flames algorithm have led to the conclusion that these forms may be fractal in time as well as fractal in space. As part of the *Electric Sheep* project, these animations are normally restricted to 128 frames and last just a few seconds. For my creative experiments I stretched out the animations by generating more frames, up to almost ten thousand in one case (Figure 104). As fractals, the shapes generated by this algorithm have a potentially infinite ‘depth’; one can zoom into an area to find more detail, and so on *ad infinitum*. I extended the duration of these animated images, which in effect is a magnification in time analogous to the magnification of spatial detail. The magnification in time of this fractal reveals greater detail that is otherwise un-

perceivable; as the animation's duration is extended, previously fuzzy areas are resolved into fast-moving particles or vibrating strings. The implication of this observation is that the animated forms produced by Drave's algorithm are fractal in time as well as in space. This is not just a fractal distribution of events in time, as in the random pattern of noise bursts in audio circuits, but a kind of fractal motion. It means that whatever frame rate we choose to use with this algorithm, there will always be visible some parts moving quickly and some moving slowly – in fact, there will always be parts moving at all speeds, but we can only ever perceive part of this range. I intend to explore this further, to research the concept of time-fractals and to understand the algorithm in order to determine whether this is indeed the case and, if so, how it works.

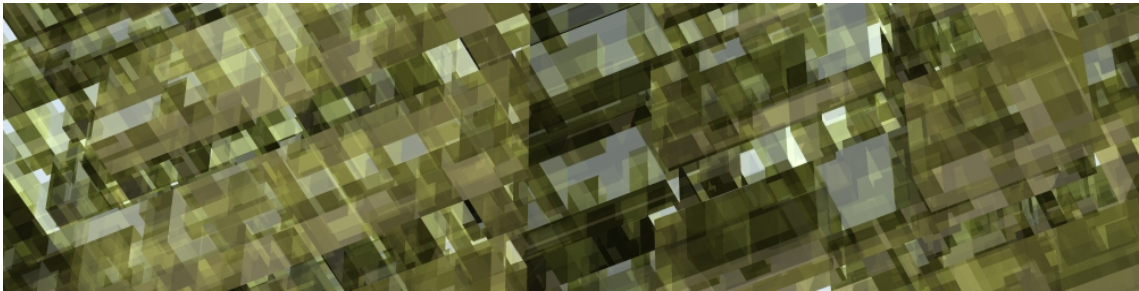

Figure 105 *P32 t+r sb3*, (2009), animation frame 17/2400.

The current work is exploring techniques of sound design to generate audio for the animations. The idea is to control audio parameters with measurements of image properties derived from the analytical methods of this project. By measuring the file size of each frame of animation (such as Figure 104 and Figure 105), we have a value that can be used to modulate the pitch or tone of a sound at a time corresponding to that frame in the animation sequence. The result is a synchronisation of visual and musical elements. Similarly, the number of unique colours could be used, or any other aspect of digital image files that is able to be quantified can be mapped to any audio control parameter. In light of the discussion in Chapter 2 about synchresis and synaesthesia, we understand that any transformation between auditory and visual stimuli is ultimately arbitrary, but in this case the connection is grounded on a relation between objective properties, and the point is that we can use these processes to experiment with the subjective effects of synchresis. This

work is evidence of the ways in which the empirical research techniques and findings of this project contribute to the development of aesthetic practice.

## Future Directions

Since the results of this project were inconclusive about the potential for the file-compression measure with images of art and design, we cannot rule out the potential value of further investigations along these lines. In fact, the success of the measure up to the introduction of art and design images suggests that we should refine the tests to establish what led to the masking of the correlation in this case. Future refinements for tests 1 and 2 would include the inclusion of greater randomness and finer detail in test stimuli in the perception of CA and random images, as well as the introduction of more numbers of colours. A repeat of test 3 would reduce the variety of styles and types of visual artefact whilst maintaining a wide spectrum of complexity. The lack of a wide objective spectrum of complexity in this sample is evidenced in the almost-vertical clustering of data points in the results of test 3, so we should address the issue in future.

It would be interesting to explore more about the aesthetic production of complexity than could be accommodated in the current project. For instance, one idea for my own art practice is for a series of paintings to begin with a blank canvas and then to make each successive painting more complex than the last. This idea could be used to explore aesthetic production by setting it as a task to art students, perhaps creating one drawing per day in a sketchbook. The collected sketchbooks would offer a fascinating insight into ways of understanding aesthetic complexity. As a basic visual analysis, we could lay out the pages in sequence from beginning to end, that is, from the simple to the complex, with each student's work in rows. Would we see the appearance of randomness anywhere in these complexity spectra, and might we find anything like the complexity classes of cellular automata? These appear to be potentially rewarding areas for future research.

It seems that the same methods and approach employed in the current project could be extended from visual art to music and be applied to an investigation of the aesthetic complexity of sound. Precisely the same psychophysical techniques would be applicable to the perception and measurement of audio stimuli as they were applied to visual stimuli. Similarly, the same technique of data compression could be used as the basis of a measure of audio file complexity. There are analogies between types of digital file for audio and visual applications: both come in lossy and non-lossy formats. Lossy compression discards perceptually insignificant information, and so there is a fundamental similarity between lossy JPEG image file compression and lossy MP3 audio file compression. A significant difference between audio complexity and visual complexity is that the former is time-based. In this project, we disregarded the temporal dimension in our study of visual aesthetics, though it was noted that complexity is related to difficulty of description in terms of the *time* it takes to create or understand it. In one sense, musical analysis might be simpler because it is oriented mainly along this single temporal dimension, which simply encodes a series of positive and negative values which express the amplitude of a waveform (and the movement of a speaker cone). This might make it seem less complex than encoding two-dimensional images, but the variety of perceived pitches, timbres and rhythms make sound a highly complex perceptual phenomenon. Whether a simple file-compression measure could effectively capture this audio complexity, and whether it might correlate with perceptions of musical complexity, are identified as potential areas for further investigation. With the experience and techniques developed in the current project, it would be a natural progression and a relatively small step to change focus from the aesthetics of visual complexity to the complexity of music and sound.

With a refinement of the current findings on visual complexity, and potential work on audio complexity, we would have a platform to investigate more fully the perception of aesthetic complexity in audio-visual media. It is possible that the effect of synchresis is sensitive to complexity. My hypothesis is that the perceptual effect is strongest when the

levels of complexity in the image and sound are approximately the same, whether at a static level or varying synchronously. This hypothesis is based on my experience and on the analysis and evaluation of the examples of art practice evidenced in this thesis. If we could establish the measurement of audio-visual complexity with file-compression and measure the aesthetic perception of synchresis with MES, we would be able to investigate the relationship between the two.

As a final word to this thesis, we can say that the visual complexity of artwork affords the opportunity of aesthetic exploration, but too little can be dull, and too much can be confusing. Like life on earth, the practice of art is an endlessly creative and increasingly complex activity. Art offers an opportunity for both artists and audiences to reflect on the process of perception itself. We now understand visual complexity as a demanding and rewarding perceptual task. Through its difficulty in making and understanding, visual complexity provides both a rich aesthetic experience and an opportunity for reflection and insight. Perception involves *making sense* of the world, in terms of both ‘understanding’ and ‘forming sensory percepts’. Seeing is understanding. Therefore, understanding *how* we see – that is, understanding the perception and aesthetics of visual art – allows for insights into ourselves and the world around us.

To see clearly is poetry, prophecy, and religion, – all in one.

John Ruskin (1856) *Modern Painters*, vol. III, part IV, chapter XVI.

# References

- Adams, D.N. (1998). *Is there an Artificial God?* Transcription of speech given at *Digital Biota* 2, Oxford, UK, 2nd. September 1998 [online].  
<http://www.biota.org/people/douglasadams/index.html> [Accessed 3 July 2008].
- Aks, D.J. and Sprott, J.C. (1996). Quantifying Aesthetic Preference for Chaotic Patterns. *Empirical Studies of the Arts*, 14 (1): 1–16.
- Arnheim, R. (1959). Information Theory: An Introductory Note. *The Journal of Aesthetics and Art Criticism*, 17 (4): 501–503.
- Arnheim, R. (1974). *Art and Visual Perception*. Berkley: University of California Press.
- Attneave, F. (1954). Some informational aspects of visual perception. *Psychological Review*, 61(3): 183–193.
- Attneave, F. (1959a). *Applications of Information-Theory to Psychology: A Summary of Basic Concepts, Methods, and Results*. New York: Henry Holt.
- Attneave, F. (1959b). Stochastic Composition Processes. *The Journal of Aesthetics and Art Criticism*, 17 (4): 503–510.
- Barron, F.B. (1952). Artistic Preferences as a Factor in Personality Style. *Journal of Psychology*, 33: 199–203.
- Barron, F.B. (1963). *Creativity & Psychological Health: Origins of Personal Vitality and Creative Freedom*. New York: Van Nostrand.
- Barrow, J.D. (2003). Art and Science – Les Liaisons Dangereuses? In: Casti, J. L. and Karlqvist, A. (eds.), 2003. *Art and complexity*. Amsterdam; London: Elsevier.
- Bateson, G. (2002). *Mind and nature: A necessary unity*. Cresskill, N.J.: Hampton Press.
- Beardsley, M.C. (1982). *The Aesthetic Point of View: Selected Essays*. Ithaca, New York; London: Cornell University Press.
- Benjamin, W. (1936). The Work of Art in the Age of Mechanical Reproduction. In: Benjamin, W. and Arendt, H. (1992). *Illuminations*. Translated by Harry Zohn. London: Fontana.

- Bennett, T. (1996). Really useless 'knowledge': A political critique of aesthetics. In: Palmer, J. & Dodson, M. (eds.) *Design and Aesthetics: A Reader*. London: Routledge. pp.33–48.
- Berleant, A. (1970). *The Aesthetic Field: A Phenomenology of Aesthetic Experience*. Springfield, Ill.: Thomas.
- Berlyne, D.E. (1971). *Aesthetics and Psychobiology*. New York: Appleton-Century-Crofts.
- Besner, C. (2007). *Studies of Visual Complexity*. M.Sc. thesis (unpublished): McGill University, Canada.
- Best, L.A., Smith, L.D., & Stubbs, A.D. (2001). Graph Use in Psychology and other Sciences. *Behavioural Processes*, 54: 155–165.
- Birkhoff, G.D. (1932). *Aesthetic Measure*. Harvard University Press.
- Bishop, C. (2004). Antagonism and Relational Aesthetics. *October*. 110: 51–79.
- Borg, G. & Borg, E. (2001). A New Generation of Scaling Methods: Level-Anchored Ratio Scaling. *Psychologica*, 28: 15–45.
- Borthwick, B. (2007). The Perfect Storm. Interview with Olaf Bender, Frank Bretschneider, Carsten Nicolai [online]. *The Wire*, 238. Available at: <http://www.thewire.co.uk/articles/185/> [accessed 27 June 2009].
- Bourriaud, N. (2002). *Relational Aesthetics*. Dijon: Les Presses du Réel.
- Bourriaud, N. (2005). *Postproduction: Culture as Screenplay: How Art Reprograms the World*. Second edition. New York: Lukas & Sternberg.
- Bruce, V., Green, P.R. and Georgeson, M.A. (2003). *Visual Perception: Physiology, Psychology and Ecology*. Fourth edition. New York: Psychology Press.
- Byron, L. and Wattenberg, M. (2008). Stacked Graphs – Geometry & Aesthetics. *IEEE Transactions on Visualization and Computer Graphics*, 14 (6): 1245–1252.
- Carroll, N. (1995). *Philosophy of Art: A Contemporary Introduction*. London: Routledge.
- Carroll, N. (2000). *Theories of Art Today*. Madison; London: University of Wisconsin Press.
- Chaitin, G.J. (1966). On the Length of Programs for Computing Finite Binary Sequences. *J. Assoc. Computing Machinery*. 13: 547–569.
- Chalmers, D.A. (1995). Facing Up to the Problem of Consciousness. *Journal of Consciousness Studies*, 2(3): 200–219.

- Chion, M. (1994). *Audio-vision: sound on screen*. Edited and translated by Claudia Gorgman. New York, Chichester: Columbia University Press.
- Cornock, S. and Edmonds, E. (1973). The Creative Process where the Artist is Amplified or Superseded by the Computer. *Leonardo*. 6: 11–16.
- Copyright, Designs and Patents Act (1998) [online]. Available at: [1988.http://www.opsi.gov.uk/acts/acts1988/ukpga\\_19880048\\_en\\_1](http://www.opsi.gov.uk/acts/acts1988/ukpga_19880048_en_1) [Accessed 4th. September, 2008].
- Crutchfield, J.P. (1990). Chaos and Complexity. In: Burkhardt, H. and Smith, B. (eds.), 1991. *Handbook of Metaphysics and Ontology*. München: Philosophia Verlag.
- Cupchik, G.C. (1983). The Scientific Study of Artistic Creativity. *Leonardo*, Special Issue: Psychology and the Arts, 16 (3): 193–195.
- DACS (Design and Artists Copyright Society), (2008). [online] Available at: <http://www.dacs.org.uk/index.php?m=15> [accessed 4th. September, 2008].
- Danto, A.C. (1964). The Artworld. *The Journal of Philosophy*. 61(19): 571–584.
- Danto, A.C. (1981). *The Transfiguration of the Commonplace*. Cambridge, MA; London: Harvard University Press.
- Danto, A.C. (1993). Responses and Replies. In: Rollins, M. (ed.), *Danto and his Critics*. London: Blackwell, pp.193–216.
- Design Museum (2007). *Dieter Rams. Selector for 25/25 - Celebrating 25 Years of Design*. [online] Available at: <http://designmuseum.org/design/dieter-rams> [accessed 8 August 2009].
- Deupree, T. (2009). The 12k aesthetic. In: *The 12k Forum* [online]. Thread started: June 30. Available at: <http://12k.com/forum/index.php> [accessed 23 July 2009].
- Dickie, G. (1961). Is Psychology Relevant to Aesthetics? *Philosophical Review*. 71 (3): 285–302.
- Dickie, G. (1971). *Aesthetics: An Introduction*. USA: Pegasus.
- Dickie, G. (1974). *Art and the Aesthetic: An Institutional Analysis*. Ithaca; London: Cornell University Press.
- Dickie, G. (1997). *The Art Circle: A Theory of Art*. Evanston, Ill.: Chicago Spectrum Press.



- Dietrich, F. (1986). Visual Intelligence: The First Decade of Computer Art (1965–1975). *Leonardo*. 19 (2): 159–169.
- Dodgson, N.A. (2008) Regularity and randomness in Bridget Riley's early Op-art. In: Brown, Cunningham, Interrant, McCormack, eds., *Proceedings of Eurographics Workshop on Computational Aesthetics in Graphics, Visualization, and Imaging*. pp.107–114.
- Domnitch, E. and Gelfand, D. (2004). Camera Lucida: A Three-Dimensional Sonochemical Observatory. *Leonardo*. 37 (5): 391–396.
- Donderi, D.C. (2000). *A complexity measure for visual graphic displays*. Paper presented at the Experimental Psychology Society/Canadian Society for Brain, Behavior and Cognitive Science Joint Meeting, Cambridge, U.K.
- Donderi, D.C. (2006a). An information theory analysis of visual complexity and dissimilarity. *Perception*, 35 (6): 823–835.
- Donderi, D.C. (2006b). Visual Complexity: A Review. *Psychological Bulletin*, 132 (1): 73–97.
- Donderi, D.C. (2007). *Re: Aesthetics & Complexity*, 26 June. ([don.donderi@mcgill.ca](mailto:don.donderi@mcgill.ca)) Email to author ([guy.birkin@ntu.ac.uk](mailto:guy.birkin@ntu.ac.uk)).
- Donderi, D.C. and McFadden, S. (2004). A single marine overlay is more efficient than separate chart and radar displays. *Displays*. 24 (4–5): 147–155.
- Donderi, D.C. and McFadden, S. (2005). Compressed file length predicts search time and errors on visual displays. *Displays*. 26 (22): 71–78.
- Draves, S. (2009). *Electric Sheep* [online]. Available at: <http://community.electricsheep.org/> [Accessed 3 June 2009].
- Draves, S. and Reckase, E. (2007). *The Fractal Flames Algorithm*. [online] Available at: [http://flam3.com/flame\\_draves.pdf](http://flam3.com/flame_draves.pdf) [accessed 13 August 2009]
- Draves, S., Abraham, R., Viotti, P., Abraham, F.D. and Sprott, J.C. (2008). *International Journal of Bifurcation and Chaos*. 18 (4): 1243–1248.
- Dunne, A. (1999). *Hertzian Tales: electronic products, aesthetic experience and critical design*. London: RCA CRD Research Publications.
- Edmonds, E.A. and Fell, M. (2005). Kyoto to Sheffield. In: *Proceedings of the 5th Conference on Creativity and Cognition*. Goldsmiths College, London, 12–15 April, 2005.

- Eisenman, R. (1967). Complexity-Simplicity Creativity, Intelligence and Other Correlates. *Journal of Psychology*. 67 (33): 1–34.
- Elkins, J. (2008). *Six Stories from the End of Representation: images in painting, photography, astronomy, microscopy, particle physics, and quantum mechanics, 1980-2000*. Stanford, Calif.: Stanford University Press.
- Eysenck, H.J. (1941a). General Factor in Aesthetic Judgments. *British Journal of Psychology*. 31: 94–102.
- Eysenck, H.J. (1941b). The Empirical Determination of an Aesthetic Formula. *Psychological Review*. 48: 83–92.
- Eysenck, H.J. (1941c). A Critical and Experimental Study of Colour Preferences. *The American Journal of Psychology*. 54 (3): 385–394.
- Eysenck, H.J. (1971). Factors Determining Aesthetic Preferences for Geometrical Designs and Devices. *British Journal of Aesthetics*, 11 (2): 154–166.
- Fechner, G. T. (1966). *Elements of Psychophysics, Vol. 1*. Translated by H. E. Adler; Edited by D. H. Howes & E. G. Boring. New York: Holt, Rinehart and Winston. (Original work published 1860.)
- Fell, M. (2009). Re: *Art and Complexity*. 12th June. From: [mark@markfell.com](mailto:mark@markfell.com) Personal communication to: [guy.birkin@ntu.ac.uk](mailto:guy.birkin@ntu.ac.uk)
- Flake, G.W. (1990). *The Computational Beauty of Nature: computer explorations of fractals, chaos, complex systems, and adaptation*. Cambridge, Mass.; London: MIT Press.
- Forsythe, A. (2008). Confounds in Pictorial Sets: The role of complexity and familiarity in basic-level picture processing. *Behavior Research Methods*. 40 (1): 116–129.
- Forsythe, A. Sheehy, N. and Sawey, M. (2003). Measuring Icon Complexity: An Automated Analysis. *Behavior Research Methods, Instruments, & Computers*. 35 (2): 334–342.
- Friedman, K. (1997). Design Science and Design Education. In: McGrory, P., ed. *The Challenge of Complexity*. Helsinki: University of Art and Design Helsinki UIAH, 54–72.
- Frye, N. (1969). *Fearful Symmetry: A Study of William Blake*. Princeton, N.J.: Princeton University Press.
- Fucks, W. (1952). On Mathematical Analysis of Style. *Biometrika*. 39 (1–2): 122–129.

- Gell-Mann, M. (1995). What is Complexity? *Complexity*. 1 (1): 16–19.
- Gell-Mann, M. (2003). Regularities and Randomness: Evolving Schemata in Science and the Arts. In: Casti, J. L. and Karlqvist, A. (eds.), 2003. *Art and complexity*. Amsterdam; London: Elsevier.
- Gianetti, C. (2004). *Cybernetic Aesthetics and Communication* [online]. Available at: [http://www.mediaartnet.org/themes/aesthetics\\_of\\_the\\_digital/cybernetic\\_aesthetics/](http://www.mediaartnet.org/themes/aesthetics_of_the_digital/cybernetic_aesthetics/) [accessed 24 June 2008].
- Gibson, J.J. (1950). *The Perception of the Visual World*. Boston, Massachusetts: Houghton-Mifflin.
- Gibson, J.J. (1978). The Ecological Approach to the Visual Perception of Pictures. *Leonardo*, 11: 227–235.
- Gibson, J.J. (1971). The Information Available in Pictures. *Leonardo*. 4: 27–35.
- Gibson, J.J. (1986). *The Ecological Approach to Visual Perception*. Dallas; London: Houghton Mifflin.
- Gleick, J. (1993). *Chaos: Making a New Science*. New edition. London: Abacus.
- Gombrich, E.H. (1977). *Art and Illusion: A study in the psychology of pictorial representation*. Fifth edition. London: Phaidon.
- Grunbaum, B. and Shephard, G.C. (1987). *Tilings and Patterns*. New York: W.H. Freeman.
- Hagerhall, C.M., Laike, T., Taylor, R.P., Küller, M., Küller, R., and Martin, T.P. (2008). Investigations of human EEG response to viewing fractal patterns. *Perception*. 37 (10): 1488–1494.
- Henke, R. (2009). *Re: Aesthetics and Complexity*. 17th December. From: [henke@monolake.de](mailto:henke@monolake.de)  
Personal communication to: [guy.birkin@ntu.ac.uk](mailto:guy.birkin@ntu.ac.uk)
- Howell, D.C. (2007). *Statistical Methods for Psychology*. 6th. ed. Belmont, Ca., USA: Thomson/Wadsworth.
- Hubel, D.H. and Wiesel, T.N. (1962). Receptive Fields, Binocular Interaction and Functional Architecture in the Cat's Visual Cortex. *J. Physiol.* 160: 106–154.
- Ikedo, R. (2009). *Test Pattern* [online]. Available at: <http://www.ryojiikedo.com/test+pattern/> [accessed 30 September 2009]

- Kahn, D. (2007). *Semiconductor's Magnetic Movie* [online]. Available at:  
[http://www.semiconductorfilms.com/root/Magnetic\\_Movie/Magnetic.htm](http://www.semiconductorfilms.com/root/Magnetic_Movie/Magnetic.htm)  
 [accessed 3 January 2008].
- Kant, I. (2007). *Critique of Judgement*. Translated by James Creed Meredith. Oxford: Oxford University Press.
- Kauffman, S.A. (2003). The Emergence of Autonomous Agents. In: Gregerson, N.H. (ed.) *From Complexity to Life*. New York: Oxford University Press, pp. 47–71.
- Kauffman, S.A. (2008). *Reinventing the Sacred: A New View of Science, Reason and Religion*. New York: Basic Books.
- Kolmogorov, A.N. (1965). Three Approaches to the Quantitative definition of Information. *Problems of Information Transmission*. 1: 1–7.
- Krauss, R. (1985). The Grid. In: *The Originality of the Avant-Garde and Other Modernist Myths*. Cambridge, MA: MIT Press. 9–22.
- Krippendorff, K. (2004). *Content Analysis: An Introduction to Its Methodology*. 2nd. ed. Thousand Oaks, CA, USA: Sage Publications.
- Kuhn, T.S. (1996). *The Structure of Scientific Revolutions*. 3rd edition. Chicago; London: University of Chicago Press.
- Laming, J. and Laming, D. (1996). J. Plateau: On the measurement of physical sensation and on the law which links the intensity of these sensations to the intensity of the source. / J. Plateau: Report on 'Psychophysical study: Theoretical and experimental research on the measurement of sensations, particularly sensations of light and of fatigue' by Mr. Delboeuf. (originally published 1872). *Psychological Research*. 59 (2): 134–144.
- Langton, C.G. (1990). Computation at the edge of Chaos: Phase-Transitions and Emergent Computation. *Physica D*. 42: 12–37.
- Langton, C.G. (1991). *Computation at the edge of Chaos: Phase-Transitions and Emergent Computation*. Ph.D. thesis, University of Michigan.
- Levinson, J. (2003). Philosophical Aesthetics: An overview. In: Levinson, J. (ed.), *The Oxford Handbook of Aesthetics*, pp.3–24. Oxford; New York: Oxford University Press.

- Li, W. and Packard, N. (1990). The Structure of the Elementary Cellular Automata Rule Space. *Complex Systems*. 4: 281–297.
- Lind, R. (1995). The Aesthetic Essence of Art. *The Journal of Aesthetics and Art Criticism*. 50 (2): 117–129.
- Locher, P. (1995). A Measure of the Information Content of Visual Art Stimuli for Studies in Experimental Aesthetics. *Empirical Studies of the Arts*, 13 (2): 183–191.
- Locher, P. and Dolese, M. (2004). A Comparison of the Perceived Pictorial and Aesthetic Qualities of Original Paintings and their Postcard Images. *Empirical Studies of the Arts*. 22 (2): 129–142.
- Locher, P., Smith, L., and Smith, J. (2001). The influence of presentation format and viewer training in the visual arts on the perception of pictorial and aesthetic qualities of paintings. *Perception*. 30 (4): 449–465.
- Luhmann, N. (2000). *Art as a Social System*. Translated by Eva M. Knodt. Stanford, Calif: Stanford University Press.
- Mandelbaum, M. (1965). Family Resemblances and Generalization Concerning the Arts. *American Philosophical Quarterly*. 2(3): 219–228.
- Mandelbrot, B.B. (1982). *The Fractal Geometry of Nature*. Oxford: Freeman.
- Mandelbrot, B.B. (2004a). *Fractals and Chaos: The Mandelbrot Set and Beyond*. New York: Springer.
- Mandelbrot, B.B. (2004b). A Theory of Roughness. *Edge* [online]. Available at: [http://www.edge.org/3rd\\_culture/mandelbrot04/mandelbrot04\\_index.html](http://www.edge.org/3rd_culture/mandelbrot04/mandelbrot04_index.html) [accessed 16 February 2009]
- Manovich, L. (2008). *Software Takes Command* [online]. (s.l.): (s.n.) Available at: [www.softwarystudies.com/softbook](http://www.softwarystudies.com/softbook) [accessed 28 June 2009].
- Martindale, C., Moore, K., & Borkum, J. (1990). Aesthetic Preference: Anomalous Findings for Berlyne's Psychobiological Theory. *The American Journal of Psychology*. 103 (1): 53–80.
- Massimi, M. *et al.* (2005). Breakdown of Cortical Effective Connectivity During Sleep. *Science*. 309 (30): 2228–2232.
- Matossian, N. (1986). *Xenakis*. London: Kahn & Averill.

- Maturana, H.R. & Varela, F.J. (1980). *Autopoiesis and cognition: the realization of the living*. London: Dordrecht.
- McWhinnie, H.J. (1965). A Review of Some Research on Aesthetic Measure and Perceptual Choice. *Studies in Art Education*. 6 (2): 34–41.
- McWhinnie, H.J. (1966). Effects of Learning on Preference for Complexity. *Perceptual and Motor Skills*. 23: 119–22.
- McWhinnie, H.J. (1971). A Review of Selected Aspects of Empirical Aesthetics III. *Journal of Aesthetic Education*. 5 (4): 115–126.
- Miall, R.C. and Tchalenko, J. (2001). A Painter's Eye Movements: A Study of Eye and Hand Movement during Portrait Drawing. *Leonardo*. 34 (1): 35–40.
- Miall, R.C. and Tchalenko, J. (2009). Eye-hand strategies in copying complex lines. *Cortex*. 45 (3): 368–376.
- Miller, W. (2008). *Gabriel Orozco: Mobile Matix*. [online]. Available at: <http://blog.art21.org/2008/09/18/gabriel-orozco-mobile-matrix/> [Accessed 5 September 2008].
- Moles, A. (1966). *Information Theory and Aesthetic Perception*. London: University of Illinois Press.
- Morton, B. and Collins, P., eds. (1992). *Contemporary Composers*. Chicago; London: St. James.
- Mureika, J.R., Cupchik, G.C. & Dyer, C.C. (2004). Multifractal fingerprints in the visual arts. *Leonardo*. 37(1): 53–56.
- Nake, F. (2005). Computer Art. A Personal Recollection. In: *C&C '05: Proceedings of the 5th Conference on Creativity & Cognition*. London, 2005. 54–62.
- Narens, L. (1996). A theory of ratio magnitude estimation. *Journal of Mathematical Psychology*. 40 (2): 109–209.
- Nicolai, C. (2009a). Artist's website [online]. Available at: <http://www.carstennicolai.de/> [accessed 14 August 2009].
- Nicolai, C. (2009b). *Grid Index*. Berlin: Die Gestalten Verlag.

- Nicolis, G. and Rouvas-Nicolis, C. (2007). Complex Systems [online]. *Scholarpedia*, 2 (11):1473. [http://www.scholarpedia.org/article/Complex\\_systems](http://www.scholarpedia.org/article/Complex_systems) [accessed 12 June 2008].
- Norman, D.A. (1988). *The Psychology of Everyday Things*. New York: Basic Books.
- Norman, D.A. (1998). *The Design of Everyday Things*. London: MIT Press.
- Norman, D.A. (2009). *Affordances and Design* [online]. Available at: [http://www.ind.org/dn.mss/affordances\\_and.html](http://www.ind.org/dn.mss/affordances_and.html) [accessed 23 October 2009].
- OED (2009). *Oxford English Dictionary* [online]. <http://dictionary.oed.com/>
- Ostwald, W. (1969). *The Color Primer: a basic treatise on the color system of Wilhelm Ostwald*. New York; London: Van Nostrand Reinhold.
- Ox, J. (2002). 2 Performances in the 21st Century Virtual Color Organ. *Proceedings of the 4th conference on Creativity & Cognition*. Loughborough, UK. 20–24.
- Ox, J. and Britton, D. (2000). The 21st Century Virtual Reality Color Organ. *IEEE MultiMedia*. 7(3): 6–9.
- Persaud, N. (2005). Humans can consciously generate random number sequences: A possible test for artificial intelligence. *Medical Hypotheses*. 65 (2): 211–214.
- Philips, E.M., and Pugh, D.S. (2000). *How to Get a PhD: A Handbook for Students and their Supervisors*. Buckingham: Open University Press.
- Popper, K. (2002). *The Logic of Scientific Discovery*. London: Routledge.
- Pynchon, T.R. (1998). *Vineland*. London: Vintage.
- Reber, R. (2008). Art in Its Experience: Can Empirical Psychology Help Assess Artistic Value? *Leonardo*. 41(4): 367–372.
- Reichardt, J. (1971). *Cybernetics, Art and Ideas*. London: Studio Vista.
- Roberts, M.N. (2007). *Complexity and Aesthetic Preference for Diverse Visual Stimuli*. PhD thesis. Universitat de les Illes Balears.
- Rousset, I. (2009). In the Room with SND, Transmediale 09. Berlin. [online] Available at: <http://www.derivative.ca/Events/SNDTransmediale/> [accessed 23 June 2009].
- Saldaña, J. (2009). *The Coding Manual for Qualitative Researchers*. London: Sage Publications.

- Salomon, D. (2004). *Data Compression: The Complete Reference*. London: Springer.
- Schmidhuber, J. (1997). Low Complexity Art. *Leonardo*. 30 (2): 97–103.
- Semiconductor (2009). Artist's website [online]. Available at:  
<http://www.semiconductorfilms.com/index.html> [accessed 3 December 2009].
- Shannon, C.E. (1948). A Mathematical Theory of Communication. *Bell System Technical Journal*, 27: 379–423; 623–656.
- Shannon, C.E. and Weaver, W. (1948). *The Mathematical Theory of Communication*. Urbana: University of Illinois Press.
- Siegel, R.M. (2004). Choices: The Science of Bela Julesz. *PLoS Biol* [online] 2(6): e172.  
 Available at:  
<http://www.ncbi.nlm.nih.gov/pmc/articles/PMC423145/pdf/pbio.0020172.pdf>  
 [accessed 10 June 2008].
- Silverman, K. (2006). *Ken Silverman's Utility Page* [online]. Available at:  
<http://advsys.net/ken/utills.htm> [accessed 27 November 2009].
- Simon, H.A. (1996). *The Sciences of the Artificial*. 3rd. edition. Cambridge, Mass.: MIT Press.
- Skiljan, I. (2009). *IrfanView* [online]. Available at: <http://www.irfanview.com/> [accessed 27 November 2007].
- Snowden, R., Thompson, P., and Troscianko, T. (2006). *Basic Vision: An introduction to visual perception*. New York: Oxford University Press.
- Solomonoff, R. (1964). A Formal Theory of Inductive Inference, Part 1 and Part 2. *Information and Control*. 7: 1–22, 224–254.
- Sprott, J.C. (1994). Automatic Generation of Iterated Function Systems. *Comput. & Graphics*. 18 (3): 417–425.
- Stevens, S.S. (1957). On the psychophysical law. *Psychological Review*, 64 (3): 153–181.
- Stevens, S.S. (1961). To Honour Fechner and Repeal His Law. *Science*, New Series, 133 (3446): 80–86.
- Stevens, S.S. (1975). *Psychophysics. Introduction to its perceptual, neural, and social prospects*. New York: Wiley-Interscience.



- Stiles, K. and Selz, P., eds. (1996). *Theories and Documents of Contemporary Art: A Sourcebook of Artist's Writings*. Berkeley, Calif.; London: University of California Press.
- Stüber, K. (1999). Ernst Haeckel: Kunstformen der Natur 1899–1904 [online]. Available at: <http://caliban.mpiz-koeln.mpg.de/haeckel/kunstformen/natur.html> [accessed 24 September 2006]
- Taylor, R.P. (2006). Reduction of physiological stress using fractal art and architecture. *Leonardo*. 39 (3): 245–251.
- Taylor, R.P., Micolich, A.P., and Jonas, D. (2002). The Construction of Jackson Pollock's Drip Paintings. *Leonardo*. 35 (2): 203–207.
- Taylor, R.P., Spehar, B., Wise, J.A., Clifford, C.W.G., Newell, B.R. and Martin, T.P. (2003). Perceptual and Physiological Responses to the Visual Complexity of Pollock's Dripped Fractal Patterns. *Journal of Nonlinear Dynamics, Psychology, and Life Sciences*. 9 (1): 89–114.
- Teghtsoonian, R. (2001). *S.S. Stevens*. In: Smelser, N.J. & Baltes, P.B. (Eds.), *International Encyclopedia of the Social and Behavioral Sciences*. Elsevier.
- Tufte, E.R. (2001). *The Visual Display of Quantitative Information*. Second edition. Cheshire, Conn.: Graphics Press.
- Visual Complexity (2009). [online] Available at: <http://www.visualcomplexity.com/vc/> [accessed 24 June 2009].
- Walther, E. (2000). *Max Bense's Informational and Semiotical Aesthetics*. [online] Available at: <http://www.stuttgarter-schule.de/bense.html> [Accessed 4 June 2008]
- Ware, C. (2004). *Information Visualization: Perception for Design*. Second edition. San Francisco, CA: Morgan Kaufmann.
- Ware, C., Arsenault, R., Plumlee, M., and Wiley, D. (2006). Visualizing the underwater behavior of humpback whales. *Computer Graphics and Applications, IEEE*. 26 (4): 14–18.
- Wattenberg, M. (2002). Arc Diagrams: Visualizing Structure in Strings. *Information Visualization, 2002. INFOVIS 2002. IEEE Symposium on Visualizing Information*. pp.110–116. [online] Available at: <http://www.research.ibm.com/visual/papers/arc-diagrams.pdf> [accessed 12 June 2008].

- Weisstein, Eric W. (2009). *Cellular Automaton* [online]. Available at: <http://mathworld.wolfram.com/CellularAutomaton.html> [accessed 30 May 2009]
- Weitz, M. (1956). The Role of Theory in Aesthetics. *The Journal of Aesthetics and Art Criticism*, 15 (1): 27–35.
- Whitelaw, M. (2007). *A Conversation with Mark Fell. Thursday, November 08, 2007.* [online]. Available at: <http://teemingvoid.blogspot.com/2007/11/conversation-with-mark-fell.html> [accessed 12 June 2009].
- Wiener, N. (1948). *Cybernetics*. New York: Wiley.
- Wilson, E.O. (1999). *Consilience: the unity of knowledge*. London: Abacus.
- Wittgenstein, L. (1966). Lectures and Conversations on Aesthetics, Psychology, and Religious Belief. Ed. Cyril Barrett. Oxford: Basil Blackwell.
- Wittgenstein, L. (1972). *The Blue and Brown Books* (Preliminary studies for the Philosophical Investigations). Oxford: Blackwell.
- Wittgenstein, L. (2001). *Philosophical Investigations: The German Text, with a Revised English Translation*. 3rd Edition. Translated by G.E.M. Anscombe. Oxford: Blackwell.
- Wixted, J., ed. (2002). *Stevens' Handbook of Experimental Psychology*. 3rd. ed., Vol. 4: Methodology in Experimental Psychology. New York; Chichester: Wiley.
- Wolfram, S. (1984). Cellular Automata as Models of Complexity. *Nature*, 311: 419–424.
- Wolfram, S. (2002). *A New Kind of Science*. Champaign, Illinois: Wolfram Media, Inc.
- Wundt, W.M. (1874). *Grundzüge der physiologischen Psychologie*. Leipzig: Engelmann.
- Zangwill, Nick (2008). Aesthetic Judgment. *The Stanford Encyclopedia of Philosophy (Fall 2008 Edition)* [online], Edward N. Zalta, ed. <http://plato.stanford.edu/archives/fall2008/entries/aesthetic-judgment/> [accessed 16 April 2008].
- Zeki, S. (2009). *Statement on Neuroaesthetics* [online]. Available at: <http://www.neuroaesthetics.org/> [accessed 23 June 2009]
- Zeki, S. and Lamb, M. (1994). The Neurology of Kinetic Art. *Brain*. 117: 607–636.

# Appendices

## Appendix A: Test 1 Instructions

The following text comprises the written instructions for test participants:

You will be presented with a series of images in a random order. Your task is to rate the complexity of the images by assigning a number to each one to show how complex you think it is. There will be a practice run to begin with.

Call the first image any number that seems appropriate to you. Then assign successive numbers in such a way that they reflect your subjective impression. There is no limit to the range of numbers that you may use. You may use whole numbers, decimals, or fractions. Try to make each number match the property as you perceive it.

## Appendix B: Copyright Law

Following are extracts from the Copyright, Designs and Patents Act 1988 (c. 48)

### Chapter II Rights of Copyright Owner

#### 16 The acts restricted by copyright in a work

(1) The owner of the copyright in a work has, in accordance with the following provisions of this Chapter, the exclusive right to do the following acts in the United Kingdom—

- (a) to copy the work;
- (b) to issue copies of the work to the public;
- (c) to perform, show or play the work in public;
- (d) to broadcast the work or include it in a cable programme service;
- (e) to make an adaptation of the work or do any of the above in relation to an adaptation;

and those acts are referred to in this Part as the “acts restricted by the copyright”.

### Chapter IV Moral Rights

#### 77 Right to be identified as author or director (‘right of paternity’)

(1) The author of a copyright literary, dramatic, musical or artistic work, and the director of a copyright film, has the right to be identified as the author or director of the work in the circumstances mentioned in this section; but the right is not infringed unless it has been asserted in accordance with section 78.

## 80 Right to object to derogatory treatment of work ('right to integrity')

(1) The author of a copyright literary, dramatic, musical or artistic work, and the director of a copyright film, has the right in the circumstances mentioned in this section not to have his work subjected to derogatory treatment.

(2) For the purposes of this section—

(a) “treatment” of a work means any addition to, deletion from or alteration to or adaptation of the work, other than—

(i) a translation of a literary or dramatic work, or

(ii) an arrangement or transcription of a musical work involving no more than a change of key or register; and

(b) the treatment of a work is derogatory if it amounts to distortion or mutilation of the work or is otherwise prejudicial to the honour or reputation of the author or director;

and in the following provisions of this section references to a derogatory treatment of a work shall be construed accordingly.

(4) In the case of an artistic work the right is infringed by a person who—

(a) publishes commercially or exhibits in public a derogatory treatment of the work, or broadcasts or includes in a cable programme service a visual image of a derogatory treatment of the work,

(b) shows in public a film including a visual image of a derogatory treatment of the work or issues to the public copies of such a film, or

(c) in the case of—

(i) a work of architecture in the form of a model for a building,

(ii) a sculpture, or

(iii) a work of artistic craftsmanship,

issues to the public copies of a graphic work representing, or of a photograph of, a derogatory treatment of the work.

## Appendix C: Interview Transcript

Test 3a Interviews: Participant 25

Time	Speaker	Transcription	Code
	GB	Have you got any questions?	Questions 2h
	P25	Um... only that one that I had about complexity with words if you're looking at the complexity of the image, how does that correlate?	
	GB	I've no idea.	

	P25	Fair enough.	
	GB	Were you comfortable with the thing in general and with the rating system?	
1:00	P25	Yeah, um. It was nice actually not having an upper limit, although I found in sometimes I was limiting myself and getting quite similar numbers, but... yeah, no I was comfortable going round and doing it.	Comfort 1
	GB	But you only got some numbers because those	
	P25	Yep. The only thing – would it be good to say now? – about seeing the numbers above the paintings.	
	GB	Yeah	
	P25	Above each picture. Yeah, seeing the numbers there, sometimes I would come to a picture and the number that instinctively came into my head was then the number I saw above the picture, so that made me think am I being truthful to what I actually think or have I been influenced by catching sight of the numbers beforehand?	Comments 10
	GB	Mm, yeah. Let me ask about the criteria that you used to rate things. What made one image more complex than another?	
	P25	Um... I suppose it was the amount of information that I was having to decipher from an image, er... Like, colour... I found colour did definitely make a difference as well. When you're looking at the geometric... the pattern ones, the sort of... those ones I definitely felt were more complex due to the colours that were in them. If the colours were more similar they seemed less complex. If the colours contrasted more, they seemed more complex. Although I was aware that they probably weren't both as complex really, but the colours seemed to change it for me.	Complexity 9 Complexity 4 Complexity 2b
	GB	Well, there is no... 'really'	
	P25	OK, yep, um...	
3:00	GB	That's why I'm doing this test. There is no, er... 'really' how complex they are at all, honestly.	
3:07	P25	I suppose another way that I rated the complexity was how long... how long I wanted to stand there and really look at it to try and get information out of it, um... The ones... the sketchy ones that you can very quickly identify what's going on, it can be pretty to look at and look at the... the way that it has been sketched, but the ones where you had to really stand and, um, be taken in by the picture I would probably have rated as a lot more complex.	Complexity 8a Complexity 9a
	GB	Mm-hm. So how did you cope with the text, the	

		ones that had words in it?	
	P25	Um... well, 'cause... it was different as well 'cause some of text was actually telling you bits and other bits of the text was just sort of like story time, if you know what I mean. It wasn't... so much giving off, er, so much information.	
	GB	So did what the words say add complexity or is it...?	
4:09	P25	In some ways I sort of tried to ignore the words, and look more like a picture, um... what was being shown.	
	GB	Yeah, right. What about the images that you preferred the most, did they have anything in common, or perhaps did you... were you aware...	
	P25	Um, the ones I preferred the most were abstract. By far, they were definitely the ones that I preferred the most. And probably the computer-generated ones as well.	
	GB	What kind of qualities did they have in common?	
	P25	Um... well, colour was definitely one thing that drew me in, but I couldn't say definite type of colour, but I do know the colours, er, influencing my preference. And shape. The shapes that were in them Colour and shape. But they... I know that the highest marks I gave were to very... some of them were very different in their colour and their shape, but it was just what grabbed me and took me. Tried to be as instinctive as possible.	Preference 5b Preference 2
	GB	I was going to ask about that. It was an instinctive decision?	
5:30	P25	Yep. It was definitely instinctive. One thing that I did think about when I was going round, though, is because I had seen some of your artwork before, therefore it was more familiar to me than some of the other ones, and I did wonder of that would be playing a part.	
	GB	Oh, I'm sure. But then again, this is similar to what would happen in the real world and you're going round a gallery, some of those are more familiar.	
	P25	Yeah, I know, I did think about it and I did think, well, still instinctively out of the ones I'm familiar with I still know which ones I prefer. So it didn't worry me too much.	
	GB	OK. What about quality, did you find that easy to do?	
	P25	Quality is...	
	GB	And how did you make those decisions?	
	P25	How did I judge quality? Actually, I did find that the hardest, 'cause I was very aware of it, how your	

		personal preference of what you think is good affects how you rate the quality.	
	GB	Yeah. I'm assuming that for most people the ease of judging the quality of these things is related to their general experience and familiarity with doing this kind of thing, so you know, if you're in art, if you're formally trained in art, it's probably an easier job to rate quality. Would you agree with that?	
	P25	I would agree with that.	
	GB	So, how much is art and design part of your day-to-day activities?	
	P25	Um...	
	GB	Any formal training?	
	P25	Er... not, well, in certain aspects of it such as, er, set design and looking at colour and I've done some art history at university, so... but never to full degree level. I would say I have a basic person's knowledge of, well, probably slightly higher than the average layman's knowledge of art, but...	Training 2a
	GB	But you don't make stuff yourself?	
8:10	P25	Not really, no.	
	GB	So how did you go about judging it then?	
	P25	From my experience throughout life	
	GB	What factors... what aspects of the images did you try and base it on?	
	P25	Different images... I suppose how... how trained I thought the artist would have to have been to have produced that piece of work. Use of colours, I suppose complexity in some ways did come into it as well, if you're looking at it that way. Do you need more?	Quality 4a Quality 11
	GB	We can wrap it up. Is there any other comments you want to make?	
	P25	Um, not...	
	GB	Was it easy or difficult overall, then? Enjoyable? Interesting?	
	P25	I found it very interesting, I really did. Thinking... having to think of... Actually one thing I really liked was that you had to round the three times and look at them all individually. On... I know that some of my thoughts changed the third time I was going round, so what I'd done the first time, but... sort of... thinking of oh no, would I have changed that. I didn't go back and change anything, but I was constantly thinking about how I look at these pictures in three different ways.	Comments 6
	GB	OK. That's it then. Thank you.	

# Appendix D: List of Codes

## Questions about the Task

01. No
02. Yes
  - a. What is the purpose of the test?
  - b. How many of the images are yours?
  - c. Are some images drawings of other images?
  - d. Where can I buy this image?
  - e. How are you going to level off the different ratings?
  - f. Are you an artist?
  - g. Is there supposed to be any pattern to how the pictures are laid out?
  - h. How does the complexity of words correlate with the complexity of the images?
  - i. Do you have a way of determining differences in preference between genders?
  - j. What would you say complexity is?
  - k. Where do the child-like images come from?

## Comfort with the Procedure

01. Yes
02. No, it was difficult
03. Complexity was most difficult
04. Quality was most difficult

## Complexity Criteria

01. Quantity of picture elements
02. Variety of picture elements
  - a. Number of varieties
  - b. Amount of variation
03. Level of detail
04. Number of colours
05. Amount of colour
06. Amount of time
  - a. In making the work
  - b. Looking at / understanding the work
07. Redundancy
08. Amount of work or difficulty
  - a. in making
  - b. in perceiving
09. Amount of information
  - a. Aesthetic
  - b. Semantic
10. Depth
11. Ambiguity
12. Size



13. Flaws

**Preference Criteria**

01. Harmony of picture elements
02. Instinctive judgement
03. Strong colours
04. Warm colours
05. Level of figuration
  - a. Representational
  - b. Abstract
06. Detail
07. Repetition / pattern
08. Quality of line
  - a. Geometric, straight
  - b. Swirly, curved
09. How much time would like to spend looking at it
10. Clean and tidy
11. Would I have it at home?
12. Computer-generated
13. Complexity
14. Emotional response
15. Pretension
16. Images covering the entire surface
17. Complementary colours
18. Relation to physical context
19. Relates to quality
20. Mundane
21. Schematic images
22. Textiles
23. Interest

**Quality Criteria**

01. Amount of work
  - a. In making
  - b. In perceiving and understanding
02. Amount of time to make the work
03. Skill
04. Difficulty in making the work
05. Suitability for exhibition
06. Coherence
07. Technical accomplishment
08. Creativity
09. Concept
10. Same as for preference
11. Complexity

12. Varied depending on medium

### Training in Art & Design

01. Formal training, actively engaged
02. Some formal training, not engaged
03. No formal training

### Comments about the Task

01. None
02. Yes
  - a. Enjoyed the experience
  - b. Unusual rating procedure, being allowed to define own scale
  - c. Shouldn't be using the same room for interviews as for people doing the task
  - d. Different to an exhibition because of the viewing angle – looking down at images on tables.
  - e. Interesting experience
  - f. Question whether objects represented are comparable
  - g. Would be good to hang the images
  - h. Too many images
  - i. Rating scores may have been influenced by the sight of images' index numbers
  - j. Art and design training helps make judgements of complexity
  - k. Images of artefacts are harder to rate than actual artefacts

## Appendix E: Coding Results

The tables below show the complete set of results for the analysis of participant interviews conducted in Test 3a (see pp.227–249).

Questions (12)	Code	Count	%(37)	Rank
No questions	01	18	48.65	1
What is the purpose of the test?	02a	5	13.51	2
How many of the images are yours?	02b	4	10.81	3
Are some images drawings of other images?	02c	2	5.41	4
Where can I buy this image?	02d	1	2.70	5
How are you going to level off the different ratings?	02e	1	2.70	5
Are you an artist?	02f	1	2.70	5
Is there a pattern to how the pictures are laid out?	02g	1	2.70	5
How does the complexity of words correlate with the complexity of the images?	02h	1	2.70	5
Do you have a way of determining differences in preference between genders?	02i	1	2.70	5
What would you say complexity is?	02j	1	2.70	5
Where do the child-like images come from?	02k	1	2.70	5

<b>Comfort with the procedure (4)</b>	<b>Code</b>	<b>Count</b>	<b>%(39)</b>	<b>Rank</b>
Comfortable	01	24	61.54	1
Uncomfortable	02	7	17.95	2
Quality was the most difficult	04	6	15.38	4
Complexity was the most difficult	03	2	5.12	4

<b>Art training / experience (3)</b>	<b>Code</b>	<b>Count</b>	<b>%(31)</b>	<b>Rank</b>
No formal training	03	16	51.61	1
Formal training, actively engaged	01	11	35.48	2
Some formal training, not engaged	02	4	12.90	3

<b>Criteria for judging Complexity (18)</b>	<b>Code</b>	<b>Count</b>	<b>%(73)</b>	<b>Rank</b>
Level of detail	03	10	13.70	1
Number of colours	04	9	12.33	2
Redundancy	07	9	12.33	2
Amount of work or difficulty: In perceiving	08b	7	9.59	4
Depth	10	7	9.59	4
Quantity of picture elements	01	5	6.85	6
Variety of picture elements: Number of varieties	02a	4	5.48	7
Amount of work or difficulty: In making	08a	4	5.48	7
Amount of colour	05	3	4.11	9
Amount of information: Aesthetic (visual)	09a	3	4.11	9
Variety of picture elements: Amount of variation	02b	2	2.74	11
Amount of time: In making the work	06a	2	2.74	11
Amount of time: Looking at / understanding the work	06b	2	2.74	11
Size	12	2	2.74	11
Amount of information	09	1	1.37	15
Amount of information: Semantic	09b	1	1.37	15
Ambiguity	11	1	1.37	15
Flaws	13	1	1.37	15

<b>Criteria for judging Preference (25)</b>	<b>Code</b>	<b>Count</b>	<b>%(50)</b>	<b>Rank</b>
Instinctive judgement	02	6	12.00	1
Strong colours (bold, saturated)	03	6	12.00	1
Quality of line: Swirly, curved	08b	6	12.00	1
How much time would like to spend looking at it	09	4	8.00	4
Level of figuration: Abstract	05b	3	6.00	5
Level of figuration: Representational	05a	2	4.00	6
Computer-generated	12	2	4.00	6
Complexity	13	2	4.00	6
Pretension (dislike)	15	2	4.00	6
Complementary colours	17	2	4.00	6
Harmony of picture elements	01	1	2.00	11
Warm colours	04	1	2.00	11
Detail	06	1	2.00	11
Repetition / pattern	07	1	2.00	11
Quality of line: Geometric, straight	08a	1	2.00	11
Clean and tidy	10	1	2.00	11

Would I have it at home?	11	1	2.00	11
Emotional response	14	1	2.00	11
Images covering the entire surface	16	1	2.00	11
Relation to physical context (how the image worked in the space)	18	1	2.00	11
Relates to quality	19	1	2.00	11
Mundane (dislike)	20	1	2.00	11
Schematic images	21	1	2.00	11
Textiles (dislike)	22	1	2.00	11
Interest	23	1	2.00	11

<b>Criteria for judging Quality (13)</b>	<b>Code</b>	<b>Count</b>	<b>%(40)</b>	<b>Rank</b>
Skill	03	8	20.00	1
Amount of work: In making	01a	6	15.00	2
Suitability for exhibition	05	6	15.00	2
Technical accomplishment (level of finish)	07	6	15.00	2
Difficulty in making the work	04	4	10.00	5
Same as for preference	10	3	7.50	6
Amount of work: In perceiving and understanding	01b	1	2.50	7
Amount of time to make the work	02	1	2.50	7
Coherence (meaningful arrangement of parts)	06	1	2.50	7
Creativity	08	1	2.50	7
Concept (the idea behind the work)	09	1	2.50	7
Complexity	11	1	2.50	7
Varied depending on medium	12	1	2.50	7

<b>Comments (12)</b>	<b>Code</b>	<b>Count</b>	<b>%(35)</b>	<b>Rank</b>
No comments	01	16	45.71	1
Interesting experience	02e	5	14.29	2
Enjoyed the experience	02a	3	8.57	3
Shouldn't be using the same room for interviews as for people doing the task	02c	2	5.71	4
Too many images	02h	2	5.71	4
Unusual rating procedure, being allowed to define own scale	02b	1	2.86	6
Different to an exhibition because of the viewing angle	02d	1	2.86	6
Question whether objects represented are comparable	02f	1	2.86	6
Would be good to hang the images	02g	1	2.86	6
Rating scores may have been influenced by index numbers	02i	1	2.86	6
Art and design training helps make judgements of complexity	02j	1	2.86	6
Images of artefacts are harder to rate than actual artefacts	02k	1	2.86	6